

# SNTE062FW

Combi Electric Oven - 6 GN 2/1

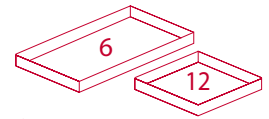

6 full-size sheet pans  
 12 half-size pans, or 12 steam table pans



Giorik Steambox Evolution Fat Collector is the combi oven that provides maximum flexibility using dry heat, moist heat, or any other combination without the use of a boiler system. The oven comes standard with a 10" Touch Screen Control interface and hundreds of preset cooking programs with a full array of menu selections.

The quality of steam is ensured by the SteamTuner. This system determines both QUALITY and QUANTITY of steam in the cooking chamber adjusting the hydration level of steam from very wet to very dry depending on user choice. The Meteo System allows Steambox Evolution to constantly monitor the climate inside the cooking chamber and quickly take action to maintain the proper degree of humidity.

With a unique pump-less design, oil and grease residue is transferred safely into a reusable container. The container is positioned outside the cooking chamber for safe content temperatures and spill free handling. At the end of the day the container and the contents can be removed from the oven and disposed using customer specific transfer methods.

## steamtuner

Steambox Evolution is fitted with a patented system that makes it possible to adjust the moisture level in the steam, thereby setting the right degree of dryness or wetness for the required cooking.



To guarantee a perfectly balanced climate inside the cooking chamber, Giorik has patented a unique humidity control system (Meteo System) using software that analyzes the relevant parameters in the cooking chamber and then regulates the production of steam or discharges excess humidity.

## RecipeTuner

The RecipeTuner interface makes it possible to modify and personalize the various programs simply and intuitively. According to the type of cooking selected, a food product's cooking, browning, degree of rising and degree of humidity can be easily modify..

## EasyService

level control cooking

The Rack Control enables different dishes to be cooked at the same time at various levels. What's more, with EasyService, a Rack Control function, all the dishes can be served at the same time.

## TECHNICAL FEATURES

- SteamTuner (patented) for tuning dry-wet steam
- Meteo System (patented) for humidity control in the cooking chamber
- Large 10" Touch Screen Control
- Ability to store over 1,000 menu items
- Heating of cooking chamber with high performance INCOLOY heating elements
- AISI 304 cooking chamber with rounded corners
- Automatic recirculating washing system (tablets or liquids)
- LED lighting
- Rapid chamber ventilation system
- Inverter-controlled fan with 6 different speeds
- Safety shutdown of fan rotation with opening of door
- Double-glazed ventilated door
- Hand Shower
- USB port for uploading & saving recipes and firmware updating

## COOKING FEATURES

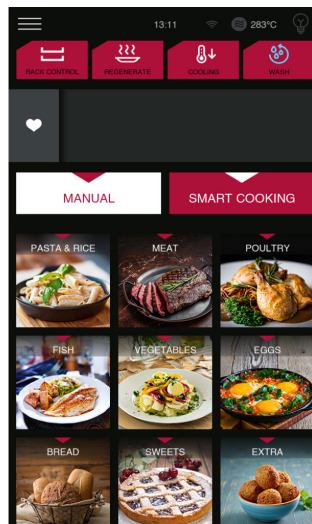

- **NEW** The Smart Cooking function creates the ideal cooking programme for your recipe in a few quick and easy steps
- Cooking modes: convection, steam, combi (convection & steam)
- Cooking by method or product type
- Temperature control from 122° to 572°F.
- Time control from 1' to 599'; infinite function
- Humidity Control from 0-100%
- Steam tuner: dry or wet steam
- Delta T cooking
- Cooking with probe
- Multi level cooking with "Easy service"

# SNTE062FW

Combi Electric Oven - 6 GN 2/1



**DIRECT  
INJECTION**

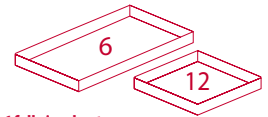

6 full-size sheet pans  
12 half-size pans, or 12 steam table pans

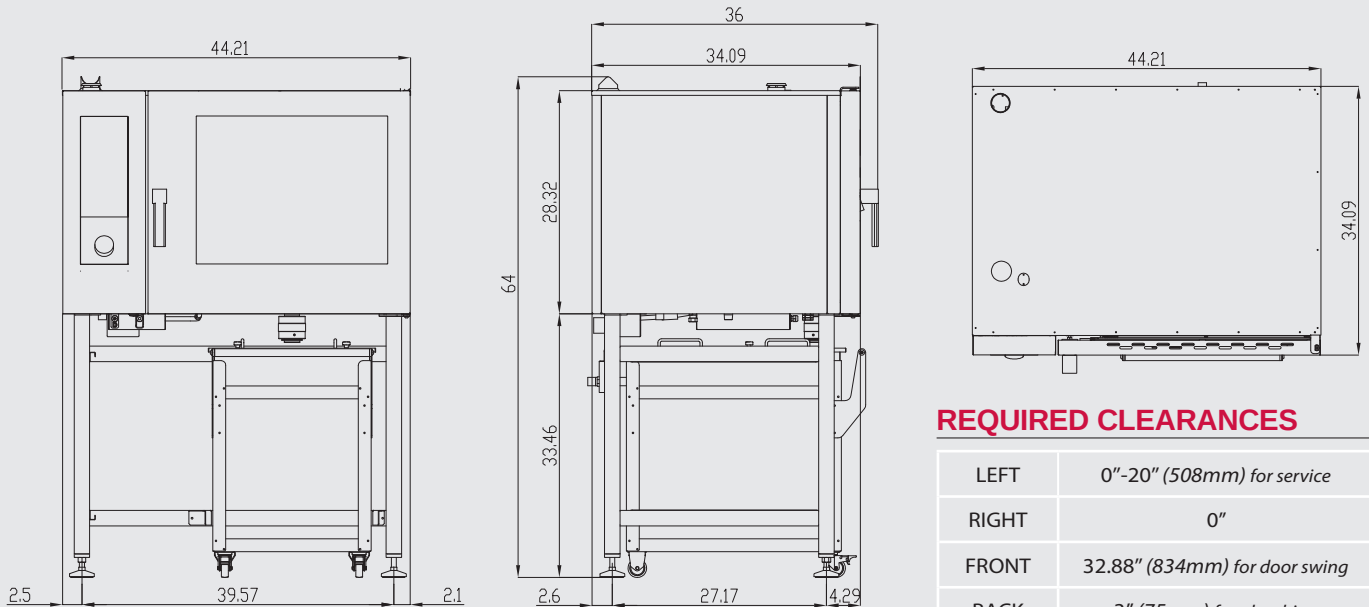

## REQUIRED CLEARANCES

LEFT	0"-20" (508mm) for service
RIGHT	0"
FRONT	32.88" (834mm) for door swing
BACK	3" (75mm) for plumbing

## DIMENSION

	HEIGHT	WIDTH	DEPTH	WEIGHT
<b>Uncrated</b>	64" (1620mm)	44.21" (1123mm)	36.42" (925mm)	452lb (205kg)
<b>Crated</b>	83" (2108mm)	52" (1321mm)	44.5" (1131mm)	618lb (280kg)

## PAN CAPACITY

12 ea. 12" x 20" x 2.5" (65mm) Steam table pans
12 ea. 13" x 18" half size sheet pan
6 ea. 18" x 26" full size sheet pan

## ELECTRICAL OPTIONS (Cord and plug not included)

Volts	Phase	Cycle/Hz	kW	Amps	Wires
208	3	60	20.4	57	3+Grnd
480	3	60	20.4	25	3+Grnd

## CONNECTIONS

3/4" GHT cold water inlet
3/4" GHT treated water for cooking as per Giorik water requirements
2" (50mm) drain

## WATER REQUIREMENTS

**NOTE: Not maintaining Giorik water quality requirements voids warranty**

Pressure (min-max): 35 - 87 PSI
Hardness (CaCO3) = Between 30-90 mg/L (Milligrams per Liter or ppm)
TDS (Total Dissolved Solids) = Between 40-150 mg/L (Milligrams per Liter or ppm)
Free Chlorine = Less than 0.1 mg/L (Milligrams per Liter or ppm)
Chlorides = Less than 20 mg/L (Milligrams per Liter or ppm)
Chloramines = Less than 0.5 mg/L (Milligrams per Liter or ppm)
Total Sulfates & Nitrates = Less than 20 mg/L (Milligrams per Liter or ppm)
Total Silica = Less than 10mg/L (Milligrams per Liter or ppm)
Total Iron = Less than 0.1mg/L (Milligrams per Liter or ppm)
pH level = 7.0 to 8.0

## OPTIONS and ACCESSORIES

Stands	Reversible doors (consult with factory about additional width considerations)
Culinary components	Cooking probes
Drain Lock	

**Giorik US Corporation**

101 East McBee Avenue  
Greenville, SC 29601 - US

1-833-446-7451

[www.giorikus.com](http://www.giorikus.com)

Rev 03.25