

# GIORIK

INNOVATIVE COOKING EQUIPMENT SINCE 1963

**mini touch**  
THE SMART WAY OF COOKING

**M MINI TOUCH**

## KM101

Combi Electric Oven - 10 GN 1/1

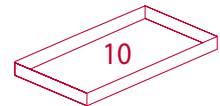

10 half size sheet pans



Giorik Minitouch is the compact combi oven that provides maximum flexibility using dry heat, moist heat, or any other combination without the use of a boiler system.

The OneTouch interface enables users to save time by starting up their favorite recipes in just one action. The oven is capable of saving cooking programs, which can be selected from the existing programs provided by Giorik or created by entering personalized settings. All these can be activated directly from the OneTouch screen in one simple move.

Moreover, the Minitouch comes standard with a 5" Touch Screen Control and hundreds of preset cooking programs with a full array of menu selections. Each cooking program can have up to 9 phases that can be adjusted depending on user experience.

Standard 1 year parts & labor warranty.

### TECHNICAL FEATURES

- Steam production by direct injection
- 5" Touch Screen Control
- Ability to store over 1000 menu items
- Heating of cooking chambers with high performance INCOLOY heating elements
- AISI 304 cooking chamber with rounded corners
- Single LED lighting on the door
- Rapid chamber ventilation system
- Inverter-controlled fan with 3 different speeds
- Safety shutdown of fan rotation by opening the door
- Double-glazed ventilated door
- USB port for uploading and saving recipes and for firmware updating
- **Optional** Automatic washing system (liquids only) - **KM101W**

### COOKING FEATURES



#### 1. Touch Screen Panel

- Cooking modes: convection, steam, combi (convection & steam)
- Cooking by method, product type or OneTouch
- Temperature control from 122° to 572°F
- Time control from 1' to 599'; infinite function
- Humidity control from 0-100%
- Multi level cooking with "Easy service"
- Delta T cooking
- Cooking with probe

#### 2. Back button

#### 3. Lights on/off button

#### 4. Schedule button

#### 5. Functions button

#### 6. Main Menu button

### OneTouch

The OneTouch interface provides a selection of user defined recipes for quick, single touch operation. OneTouch load and serve perfect food products.

### RecipeTuner

The RecipeTuner interface makes it possible to modify and personalize the various programs simply and intuitively. According to the type of cooking selected, a food product's cooking, browning, degree of rising and degree of humidity can be easily modified.

### EasyService

level control cooking

The Rack Control enables different dishes to be cooked at the same time at various levels. What's more, with EasyService, a Rack Control function, all the dishes can be served at the same time

## KM101

Combi Electric Oven - 10 GN 1/1



**DIRECT INJECTION**

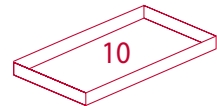

**10 half size sheet pans**

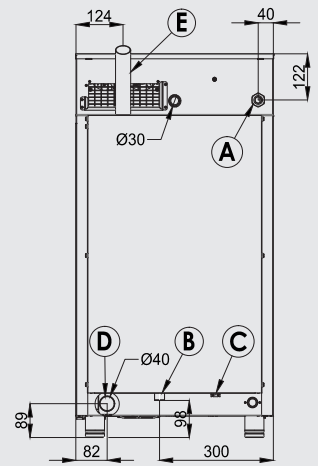
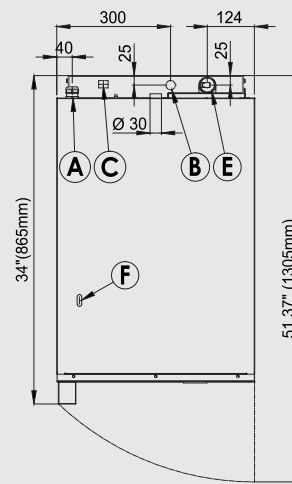
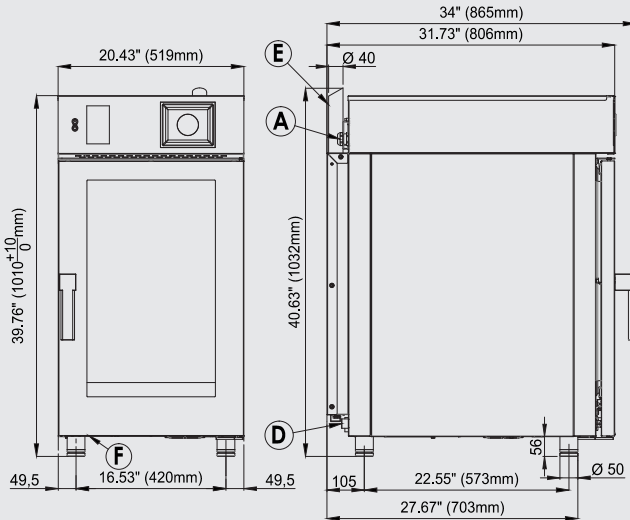

### LEGEND

A	Electrical Inlet
B	Water Inlet
C	Ground/Earth Connection
D	Drain
E	Exhaust
F	Detergent lines (KM101W)

### REQUIRED CLEARANCES

LEFT	2" (50mm) for service
RIGHT	2" (50mm) for service
FRONT	20.5" (520mm) for door swing
BACK	3" (75mm) for plumbing

### DIMENSION

	HEIGHT	WIDTH	DEPTH	WEIGHT
<b>Uncrated</b>	43.31" (1100mm)	20.43" (519mm)	31.73" (806mm)	216lb (98kg)
<b>Crated</b>	46.26" (1175mm)	22.83" (580mm)	38.58" (980mm)	242lb (110kg)

### PAN CAPACITY

10 ea. 13" x 18" half size sheet pan

### ELECTRICAL OPTIONS (Cord & plug not included)

Volts	Phase	Cycle/Hz	kW	Amps	Wires
208	3	60	15	42	3+Grnd

### CONNECTIONS

3/4" GHT treated water for cooking as per Giorik water requirements  
1.58" (40mm) drain

### WATER REQUIREMENTS

**NOTE: Not maintaining Giorik water quality requirements voids warranty**

Pressure (min-max): 35 - 87 PSI
Hardness (CaCO <sub>3</sub> ) = between 30-90 mg/L ( Milligrams per Liter or ppm)
TDS (Total Dissolved Solids)= between 40-150 mg/L ( Milligrams per Liter or ppm)
Free Chlorine = Less than 0.1 mg/L ( Milligrams per Liter or ppm)
Chlorides = Less than 20 mg/L ( Milligrams per Liter or ppm)
Chloramines = Less than 0.5 mg/L ( Milligrams per Liter or ppm)
Total Sulfates & Nitrates = Less than 20 mg/L ( Milligrams per Liter or ppm)
Total Silica = Less than 10mg/L ( Milligrams per Liter or ppm)
Total Iron = Less than 0.1 mg/L ( Milligrams per Liter or ppm)
pH level= 7.0 to 8.5

### OPTIONS and ACCESSORIES

Stands	Cooking probes
Stacking system	Culinary components
Reversible doors (consult with factory)	

### Giorik US Corporation

400 Birnie Street, Suite D  
Greenville, SC 29611 - US

1-833-446-7451

[www.giorikus.com](http://www.giorikus.com)

Rev. 06/16/22