

GIORIK

INNOVATIVE COOKING EQUIPMENT SINCE 1963

Steam BOX R

EVOLUTION



Steam
box **R**
EVOLUTION

The beginning of a new era



The new R range is the combination of technological innovation, design and ease of use. Efficient, spacious, always connected, intuitive and versatile in cooking. R is the Revolution that your kitchen deserves to Restart!

R

TOUCH SCREEN CONTROL
INSTANT STEAM



6 GN 1/1
6 Half Sheet Pans (13" x 18")



6 GN 2/1
6 Full Sheet Pans (18" x 26")
or 12 Half Sheet Pans (13" x 18")



10 GN 1/1
10 Half Sheet Pans (13" x 18")



10 GN 2/1
10 Full Sheet Pans (18" x 26")
or 20 Half Sheet Pans (13" x 18")

Two level steam

SuperSteam

SuperSteam provides 2-level steam regulation. The right degree of humidity is calibrated according to your preferences. The selection of the two humidity levels, in fact, allows you to always have the perfect degree of hydration in the chamber for cooking every food.



Custom programs



RecipeTuner

The RecipeTuner interface makes it possible to modify and personalize the various programs simply and intuitively. RecipeTuner changes according to the type of cooking set, to regulate cooking, browning and degree of humidity. The interfaces work with both pre-set programs and those created by the chef.

EasyService level control cooking

The new Rack Control enables different dishes to be cooked at the same time at various levels. What's more, with EasyService, a new Rack Control function, all the dishes can be served at the same time.



Cloud connection



Giorik Remote Analysis

All Giorik ovens are supplied with electronics which connect with the Giorik Cloud. This allows information about the oven to be gathered, so equipment errors and parameters can be analyzed remotely. Connection to the Cloud also enables the oven software to be updated in real time.



Giorik Smart Recipes

Create, edit, duplicate and distribute your personalized recipes to all your remote ovens. Develop customized recipes and keep them in the cloud for future access. Just a click away!





Intuitive and versatile

OneTouch

OneTouch enables users to save time by starting up their favorite recipes in just one action. The oven is capable of saving cooking programs, which can be selected from the existing programs provided by Giorik or created at will during use by entering personalized settings. All these can be activated directly from the OneTouch screen in one simple move.

Humidity control

To guarantee a perfectly balanced climate inside the cooking chamber, Giorik has adopted a unique relative humidity control system in the chamber to provide the right amount of moisture at all times.

Sometimes you need to evacuate the steam from the cooking chamber quickly or switch to a dry environment for crisping and browning. Instead of requiring you to open the door, which releases heat, our humidity release system uses a servo-controlled butterfly valve and air suction system to quickly and completely remove steam.



Automatic washing system

The Steambox Evolution R comes standard with the AUTOMATIC WASH SYSTEM. The intuitive interface allows users to quickly start cleaning at the end of the cooking cycle or at the end of the day by selecting one of the four wash programs available, from HARD to RINSING ONLY.



Only liquid detergent

Features recap

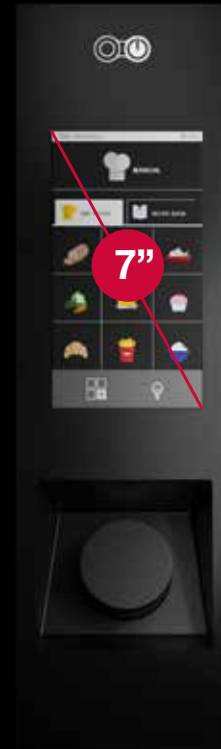

- 7" touchscreen control;
- INSTANT steam production system;
- SUPER STEAM: 2 levels of steam quality control;
- Immediate start of the cooking cycle with "ONE TOUCH" programs;
- Temperature control from 122 to 572 °F;
- Timer from 1 to 599 minutes, with infinite setting;
- Cooking method: convection, steam, combined (steam/ convection);
- Holding function, cold and hot smoking mode;
- Pre-set cooking programs. 9 cooking phases can be set for each program;
- Delta T cooking mode (with optional core probe);
- Core probe cooking (with optional core probe);
- RackControl with EasyService;
- Recipe Tuner;
- Cooking chamber humidity control;
- Inverter-controlled fan with 6 speed settings;
- Motorized vent valve opening;
- Automatic washing system with liquid detergent + rinse agent;
- Chamber LED lighting;
- Wi-Fi as standard;
- USB connection;
- Optional Left hinged door available from factory.



- (1) **DOOR** - The door has double-pane glass and heavy insulation to avoid the risk of burns. It also has a double drip tray on the front of the oven and on the door. Upon request, we can build the door with left hinges.
- (2) **LIGHTING** - The LED lights fitted to the door provide great visibility inside the cooking chamber while saving energy.
- (3) **MAIN CONTROLLER DIAL** - The main controller dial has been built into an alcove to reduce the chance of breaking or accidentally changing the parameters.
- (4) **TOUCH SCREEN PANEL** - 7" touch screen.
- (5) **INSTRUMENT COMPARTMENT** - The instrument compartment is ventilated and protected by a dust filter. The panel can be accessed from the front for easy service.

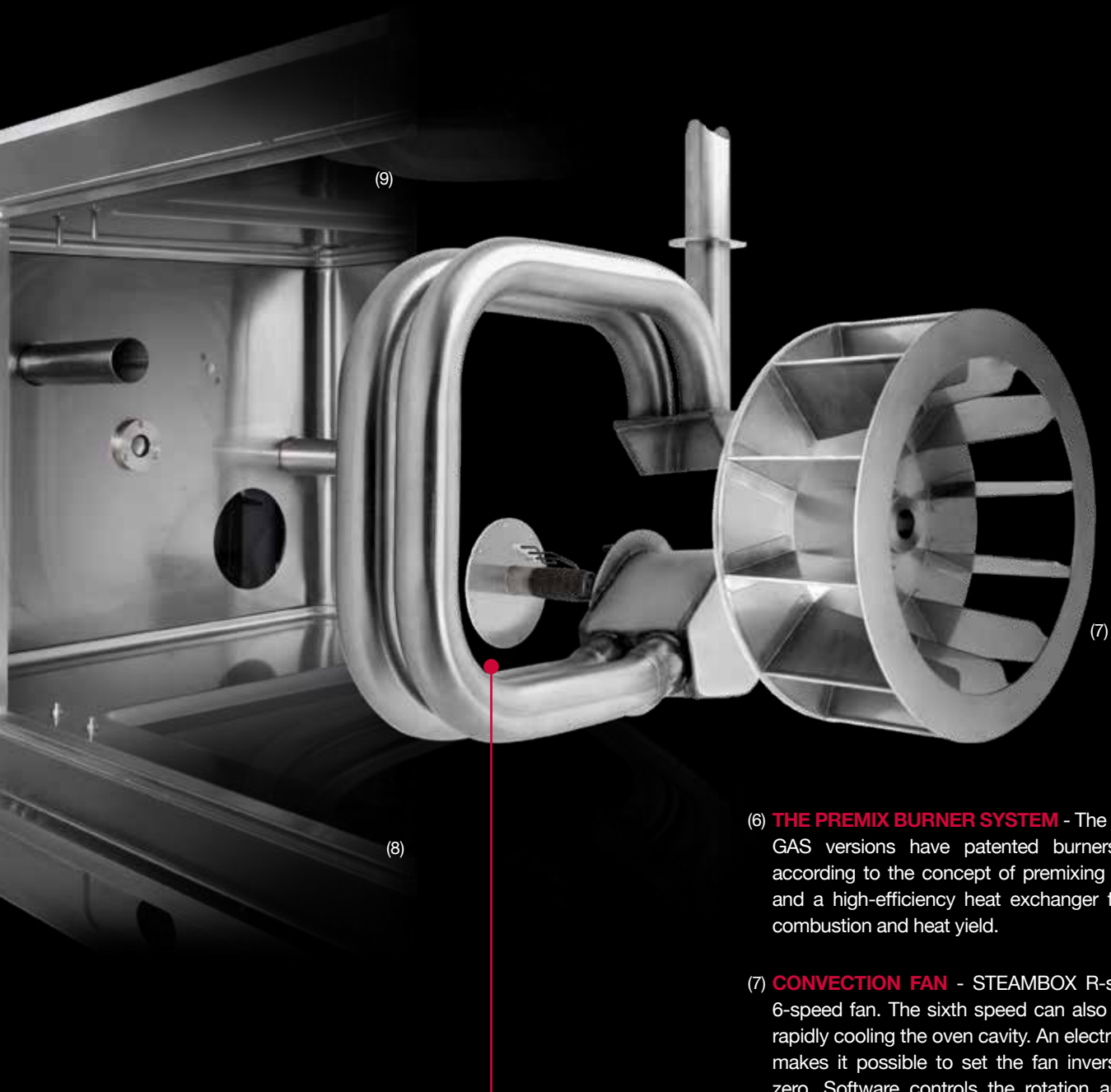

(6) **GIORIK PATENT**
THE PREMIX BURNER SYSTEM

(6) **THE PREMIX BURNER SYSTEM** - The STEAMBOX GAS versions have patented burners, designed according to the concept of premixing gas and air, and a high-efficiency heat exchanger for optimum combustion and heat yield.

(7) **CONVECTION FAN** - STEAMBOX R-series has a 6-speed fan. The sixth speed can also be used for rapidly cooling the oven cavity. An electronic inverter makes it possible to set the fan inversion time to zero. Software controls the rotation and sets the alternation times based on the cooking cycle. When the door opens the fan stops almost immediately.

(8) **COOKING CHAMBER** - The cooking chamber has smooth covered corners to avoid buildup of grease and grime. The pan racks and fan cover are easy to remove without special tools for fast cleaning. The new double-ridge gasket is easy to replace.

(9) **AUTOMATIC WASHING** - Automatic washing system with liquid detergent.

(10) **SUPERSTEAM** - 2-level steam regulation.

R ELECTRIC VERSION		7" TOUCH SCREEN CONTROL - VERSION WITH INSTANT STEAM		
Model	Dimensions	Capacity	Voltage	Power
	WxDxH			
⚡	inches	Full or half size sheet pan	V/PH	kW
⚡ SERE061W	34.68x33.98x33.66	6 HS	208/3	10.4
⚡ SERE062W	34.61x44.21x36.42	6 FS / 12 HS	208/3 480/3	20.4
⚡ SERE101W	45.71x33.98x33.66	10 HS	208/3	14.7
⚡ SERE102W	45.63x44.21x36.42	10 FS / 20 HS	208/3 480/3	25.8

R GAS VERSION		7" TOUCH SCREEN CONTROL - VERSION WITH INSTANT STEAM		
Model	Dimensions	Capacity	Voltage	Power
	WxDxH			
⚡	inches	Full or half size sheet pan	V/PH	kW
🔥 SERG061W	34.68x33.98x33.66	6 HS	120/1	0.4 ⚡
🔥 SERG062W	34.61x44.21x36.42	6 FS / 12 HS	120/1	0.4 ⚡
🔥 SERG101W	45.71x33.98x33.66	10 HS	120/1	0.7 ⚡
🔥 SERG102W	45.63x44.21x36.42	10 FS / 20 HS	120/1	0.8 ⚡

Giorik US Corporation
400 Birnie Street, Suite D
Greenville, South Carolina 29611 | USA

tel. 1-833-446-7451
e-mail: info@giorikus.com

www.giorikus.com

Giorik SpA
Via Cavalieri di Vittorio Veneto, 14
32036 Sedico (BL) | ITALY

tel. +39.0437.807200 | fax +39.0437.807001
e-mail: info@giorik.com

www.giorik.com

