

GIORIK

INNOVATIVE COOKING EQUIPMENT SINCE 1963

Steambox EVOLUTION



SETG061W

Combi Gas Oven - 6 GN 1/1



DIRECT
INJECTION



6 half-size sheet pans,
6 steam table pans



Giorik Steambox Evolution is the high-end level combi oven that provides maximum flexibility using dry heat, moist heat, or any other combination without the use of a boiler system.

The quality of steam is ensured by the SteamTuner. This system determines both QUALITY and QUANTITY of steam in the cooking chamber adjusting the hydration level of steam from very wet to very dry depending on user choice.

The Meteo System allows Steambox Evolution to constantly monitor the climate inside the cooking chamber and quickly take action to maintain the proper degree of humidity.

The Steambox Evolution comes standard with a 9" wide Touch Screen Control interface and hundreds of preset cooking programs with a full array of menu selections. Each cooking program can have up to 9 phases that can be adjusted depending on user experience.

Standard 2 year parts & labor warranty.

steamtuner

Steambox Evolution is fitted with a patented system that makes it possible to adjust the moisture level in the steam, thereby setting the right degree of dryness or wetness for the required cooking.

Meteo SYSTEM

To guarantee a perfectly balanced climate inside the cooking chamber, Giorik has patented a unique humidity control system (Meteo System) using software that analyzes the relevant parameters in the cooking chamber and then regulates the production of steam or discharges excess humidity.

RecipeTuner

The RecipeTuner interface makes it possible to modify and personalize the various programs simply and intuitively. According to the type of cooking selected, a food product's cooking, browning, degree of rising and degree of humidity can be easily modify..

EasyService

level control cooking

The Rack Control enables different dishes to be cooked at the same time at various levels. What's more, with EasyService, a Rack Control function, all the dishes can be served at the same time.

TECHNICAL FEATURES

- SteamTuner (patented) for tuning dry-wet steam
- Meteo System (patented) for humidity control in the cooking chamber
- Large 9" Touch Screen Control
- Ability to store over 1000 menu items
- Heating of cooking chambers with PREMIX GAS BURNER
- AISI 304 cooking chamber with rounded corners
- Automatic recirculating washing system (tablets or liquids)
- LED lighting
- Rapid chamber ventilation system
- Inverter-controlled fan with 6 different speeds
- Safety shutdown of fan rotation by opening the door
- Double-glazed ventilated door
- USB port for uploading & saving recipes and for firmware updating

COOKING FEATURES

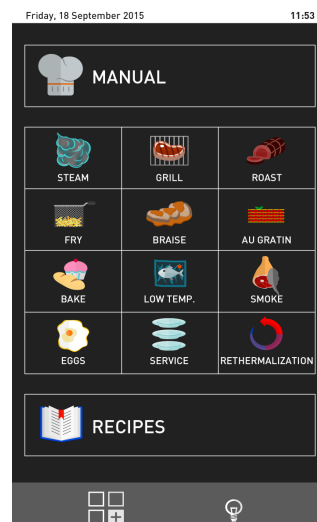

- Cooking modes: convection, steam, combi (convection & steam)
- Cooking by method or product type
- Temperature control from 122° to 572°F
- Time control from 1' to 599'; infinite function
- Humidity Control from 0-100%
- SteamTuner: dry or wet steam
- Delta T cooking
- Cooking with probe
- Multi level cooking with "Easy service"

SETG061W

Combi Gas Oven - 6 GN 1/1



DIRECT INJECTION



6 half-size sheet pans,
6 steam table pans

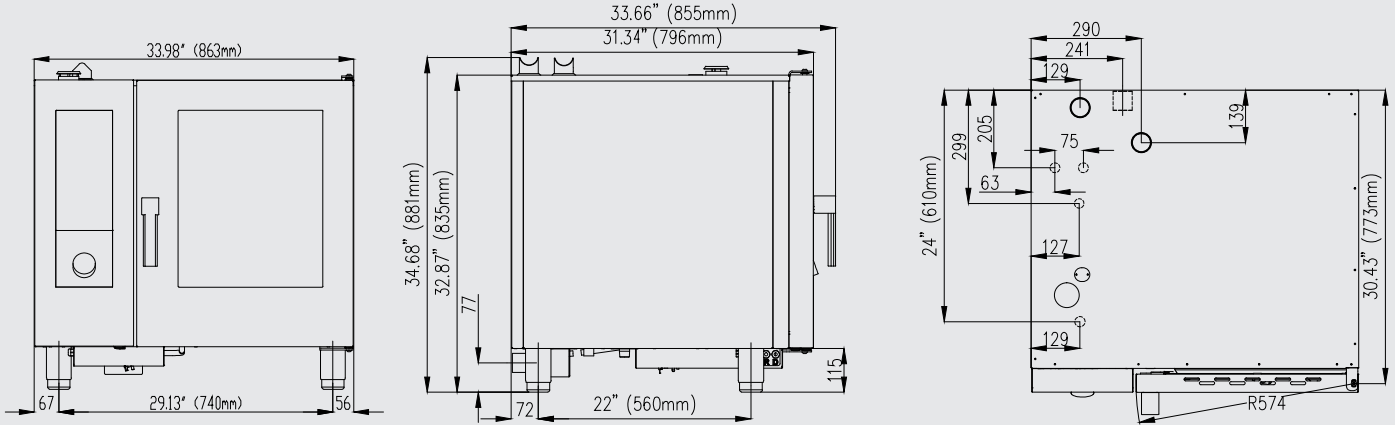

REQUIRED CLEARANCES

LEFT	0"-20" (508mm) for service
RIGHT	0"
FRONT	22.6" (574mm) for door swing
BACK	3" (75mm) for plumbing

DIMENSION

	HEIGHT	WIDTH	DEPTH	WEIGHT
Uncrated	34.68" (881mm)	33.98" (863mm)	33.66" (855mm)	300lb (137kg)
Crated	40.25" (1022mm)	36.75" (934mm)	36" (915mm)	344lb (157kg)

PAN CAPACITY

6 ea. 12" x 20" x 2.5" (65mm) Steam table pans
6 ea. 13" x 18" half size sheet pan

ELECTRICAL OPTIONS (Cord & plug not included)

Volts	Phase	Cycle/Hz	kW	Amps	Wires
120	1	60	0.4	3.5	2+Grnd

CONNECTIONS

3/4" GHT cold water inlet
3/4" GHT treated water for cooking as per Giorik water requirements
2" (50mm) drain
1/2" NPT gas inlet

WATER REQUIREMENTS

NOTE: Not maintaining Giorik water quality requirements voids warranty

Pressure (min-max): 35 • 87 PSI
Hardness (CaCO3) = Between 30-90 mg/L (Milligrams per Liter or ppm)
TDS (Total Dissolved Solids)= Between 40-150 mg/L (Milligrams per Liter or ppm)
Free Chlorine = Less than 0.1 mg/L (Milligrams per Liter or ppm)
Chlorides = Less than 20 mg/L (Milligrams per Liter or ppm)
Chloramines = Less than 0.5 mg/L (Milligrams per Liter or ppm)
Total Sulfates & Nitrates = Less than 20 mg/L (Milligrams per Liter or ppm)
Total Silica = Less than 10mg/L (Milligrams per Liter or ppm)
Total Iron = Less than 0.1mg/L (Milligrams per Liter or ppm)
pH level = 7.0 to 8.0

OPTIONS and ACCESSORIES

Stands	Reversible doors (consult with factory about additional width considerations)
Stacking system	Culinary components
Cooking Probes	Drain Lock
Tablet detergent and rinse aid	

BTUH

41000

Giorik US Corporation

400 Birnie Street, Suite D
Greenville, SC 29611- US

1-833-446-7451

www.giorikus.com

Rev. 11/22