

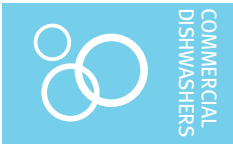

Project _____
 AIA # _____ SIS # _____
 Item # _____ Quantity _____ C.S.I. Section 114000



CL86-BAS GAS

High Temperature Rack Conveyor Dishwashing Machine



SPECIFIER STATEMENT

Specified dishwasher will be Hobart CL86 Base gas tank heat model. Features include 22" power scrapper, Complete Delime™ with Delime Notification, Auto Dispensing and Booster Guard™, capless anti-clogging wash arms, 342 racks per hour, 114 gallons per hour pumped final rinse, ENERGY STAR® (pending), insulated ergonomic cabinet style doors, touchscreen controls with WiFi connectivity, and NSF approved pot and pan cycle mode. The wash tank utilizes durable precision pressure sensor monitors in lieu of conventional mechanical floats. The 19.5" standard chamber height will accommodate up to (6) standard sheet pans at a time on an open-end sheet pan rack.

STANDARD FEATURES

- + 114 gallons per hour pumped final rinse
- + 342 racks per hour
- + 22" power scrapper
- + ENERGY STAR® Certified (Pending)
- + Complete Delime™ with Delime Notification, Auto Dispensing and Booster Guard™
- + Internal stainless steel pressure-less 24 kW booster heater (70°F rise)
 - Single point electrical connection standard
- + Capless, anti-clogging wash arms
- + Large double door opening for ease of cleaning
- + 19.5" chamber height opening (accepts sheet pans)
- + Doors are insulated & hinged with door interlock switches
- + User-friendly smart touchscreen controls with diagnostics & troubleshooting
- + WiFi connectivity
- + SmartConnect app and cloud with machine status, temperature logs, error code reporting, and cost, consumption and usage analysis
- + Energy saver mode (programmable auto-shut down)
- + NSF rated configurable pot and pan cycle
- + Self-aligning wash manifolds
- + Stainless steel self-draining pump and impeller
- + Sloping scrap screens and deep scrap baskets
- + Rapid return conveyor drive mechanism
- + Service diagnostics
- + Door actuated drain closure
- + Vent fan control

OPTIONS & ACCESSORIES (Available at extra cost)

- Standard, short, and extended stainless steel vent hoods
- Direct drive unloader – adds 38" length; Reference spec F48944 for more details
- Side loader – SL23 adds 23" length, SL30 adds 30" length; Reference specs F40926 and F40927 for more details
- Blower-dryer – adds 33 1/4" to length; Reference spec F48945 (electric blower-dryer) and F48950 (steam blower-dryer) for more details (ships separate from dishmachine, contact Hobart Service for installation)
- Drain water tempering kit
- Flanged feet kit (requires three kits)
- Table limit switch with 20' cable
- Correctional package (factory installed, contact Hobart for details)
- Water hammer arrester
- Factory-mounted circuit breakers (contact Hobart for details)

CL SERIES – CL86-BAS GAS

Approved by _____ Date _____ Approved by _____ Date _____



CL86-BAS GAS

High Temperature Rack Conveyor Dishwashing Machine

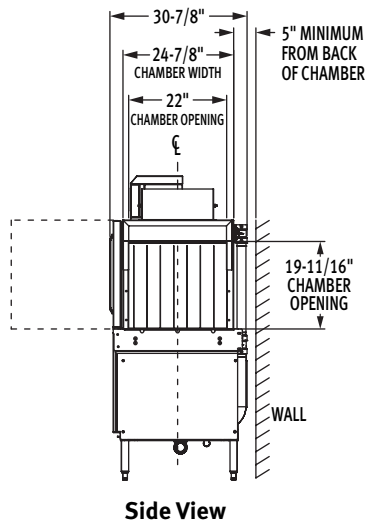
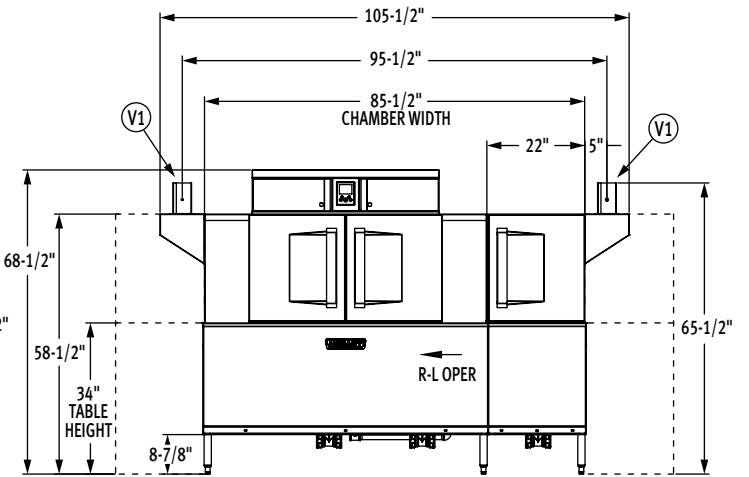
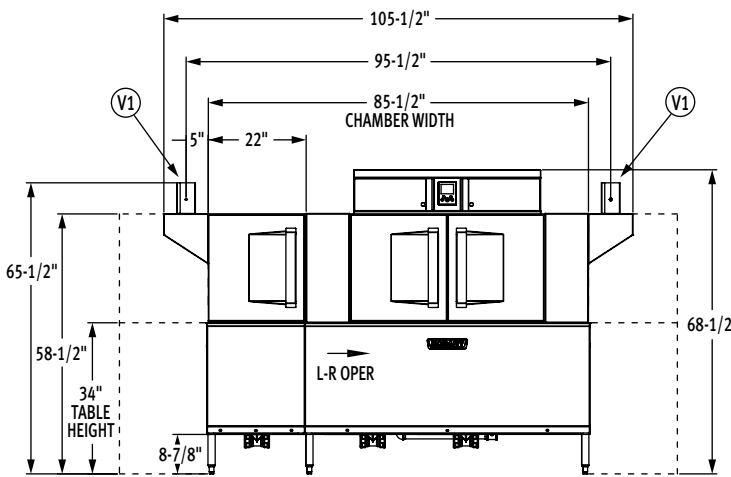
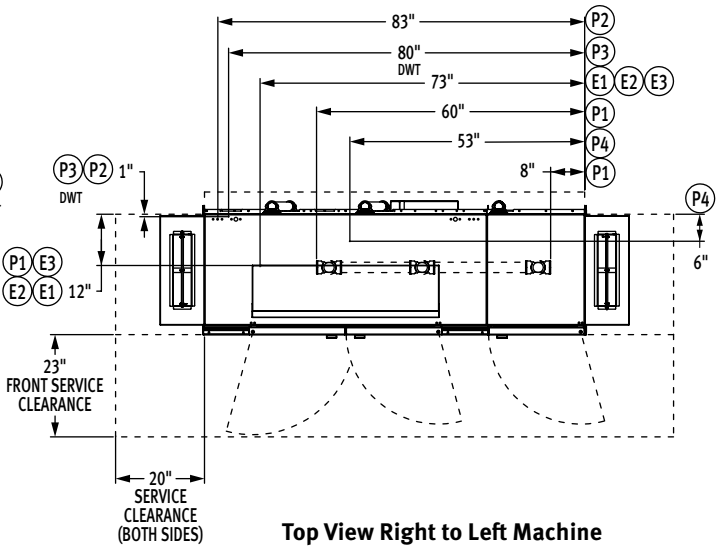
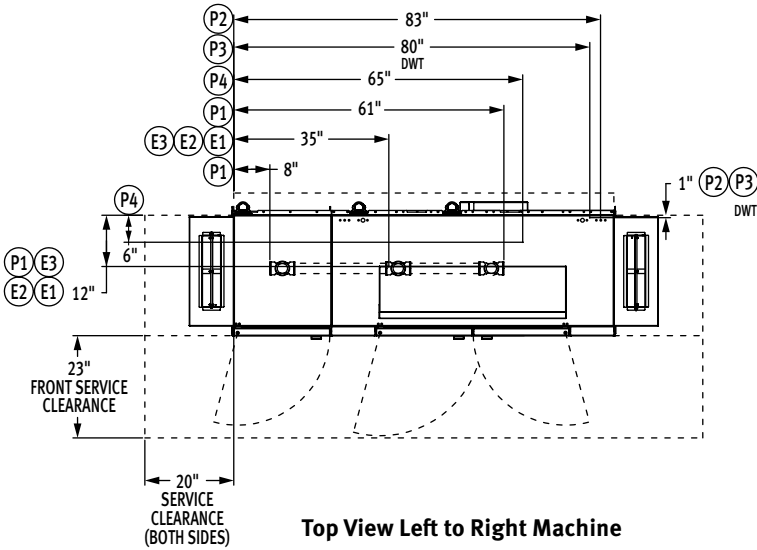

MODEL:
CL86-BAS GAS
L-R OPERATION
00-563927
REV A

MODEL:
CL86-BAS GAS
R-L OPERATION
00-563937
REV A



CL86-BAS GAS

High Temperature Rack Conveyor Dishwashing Machine

LEGEND

Electrical Connections	
SINGLE POINT CONNECTION	
E1	Electric connection, single point: motors, controls, with 24kW electric booster heater, 65" AFF.
DUAL POINT CONNECTION WITH BOOSTER	
E2	Electric connection: motors, 62" AFF.
E3	Electric connection: controls, 24kW booster heater, 65" AFF.
Plumbing Connections	
P1	Drain: 2" FPT, 7-3/8" AFF, two possible connections; may be drained to either side of drain housing, plug opposite side.
P2	Common hot water connection: 1/2" FPT, 12" AFF. See plumbing notes for required temperatures.
P3	Optional drain water tempering. Cold water connection: 1/2" FPT, 12" AFF, cold temperature 80°F maximum.
P4	Gas connection – Natural, 1/2" FPT, 11" AFF; 3.5" minimum, 7" maximum W.C. incoming.
P4	Gas connection – L.P., 1/2" FPT, 11" AFF; 8" minimum, 11" maximum W.C. incoming.
Vent Connections	
V1	Optional vent hoods: 4" x 16" vent stack with damper. Load end 200 CFM, unload end 400 CFM.

SPECIFICATIONS

Capacities

Racks per Hour (NSF rated)	342
Wash Tank (U.S. gallons)	23
Power Rinse Tank (U.S. gallons)	22
Power Scrapper (U.S. gallons)	23
Conveyor Speed (feet per minute)	9.5

Motor Horsepower

Drive	1/6
Wash	2
Power Rinse	2
Power Scrapper	2
Final Rinse	2/3

Water Consumption

U.S. Gallons per Hour	114
U.S. Gallons per Rack	0.33
Peak Drain Flow (U.S. gallons per minute)	38

Heating

Tank Heat, LP or Natural Gas (BTU per hour)	2 x 78,000
Electric Booster (built-in) (kW for 70°F rise)	24
Electric Booster (field conversion) (kW for 40°F rise)	12

Venting

Load End (minimum CFM)	200
Unload End (minimum CFM)	400
(Gas exhaust venting must be installed according to local code)	

Shipping Weight (approximate) 995 lbs.

Crated Dimensions 96"L x 38"W x 79"H

E1	Single Point Electrical Connection with Internal Booster	
	(E1) Motors, Controls, 24kW Booster Heater	
Voltage	Rated Amps	Minimum Supply Circuit Ampacity/ Maximum Protective Device
	208/60/3	94.3
240/60/3	82.4	100

E2 E3	Dual Point Electrical Connection with Internal Booster (Field Conversion Only)			
	(E2) Motors		(E3) Controls, 24kW Booster Heater	
Voltage	Rated Amps	Minimum Supply Circuit Ampacity/ Maximum Protective Device	Rated Amps	Minimum Supply Circuit Ampacity/ Maximum Protective Device
	208/60/3	20.7	30	73.6
240/60/3	17.7	25	64.7	80

WARNING: Electrical and grounding connections must comply with the applicable portions of the National Electrical Code and/or other local electrical codes.

CAUTION: Certain materials including silver, aluminum, and pewter are attacked by sodium hypochlorite (liquid bleach).

ATTN: Plumbing connections must comply with applicable sanitary, safety and plumbing codes.

CL86-BAS Gas Heat Dissipation		
Booster	BTU/HR.	
	Latent	Sensible
Without Booster	47,300	20,300
12kW Booster	55,400	23,800
24kW Booster	66,300	28,400

NOTE: 24kW Booster Heater field convertible to 12kW when 140°F incoming water provided. (Conversion instructions located in machine control box. Contact factory for 12kW booster amperage ratings.)

NOTE: Additional Voltages and Amperages are available, see document F48913.



CL86-BAS GAS

High Temperature Rack Conveyor Dishwashing Machine

Plumbing Notes: Water hammer arrestor (meeting ASSE-1010 standard or equivalent) to be supplied (by others) in common water supply line at service connection.

Recommended water hardness to be 3 grains or less for best results.

Minimum incoming hot water temperatures:

110°F for 24kW internal booster

140°F for 12kW field converted internal booster

180°F without internal booster for high temperature sanitizing

130°F without internal booster for chemical sanitizing

Building flowing water pressure to dish machine is 20 to 65 PSI at the machine.

For convenience when cleaning, water tap should be installed near machine with heavy duty hose and squeeze valve.

For chemical sanitizing applications, feeder must be certified to NSF Standard 29.

For natural gas, pressure to the burner (customer connection) should be 3.5" minimum, 7" maximum W.C.

For LP gas, pressure to the burner (customer connection) should be 8" minimum, 11" maximum W.C.

If gas pressure is higher than 7" (natural) or 11" (LP) W.C., a pressure regulating valve must be installed (by others) in the gas line to the dishwasher.

Gas heat (natural or LP) BTU/Hr. input – 156,000.

Gas exhaust venting must be installed according to local code. Electrical interlock connection provided for customers airflow switch to prevent heat being applied if the exhaust fans are not operating. Do not connect flue to power vent. See installation manual for gas venting.

Miscellaneous Notes: All dimensions taken from floor line may be increased approximately 3/4" or decreased 1/2".

For optimal performance, Hobart recommends maintaining a dishroom temperature of 65°F (18°C) or higher, as lower temperatures may hinder the machine's capacity to operate effectively (with lower performance as ambient temperature decreases).

Electrical Note: Dishmachine not provided with internal GFCI protection.

VENT HOOD OPTIONS (Adjustable, vent stack can be adjusted 1" to either side)

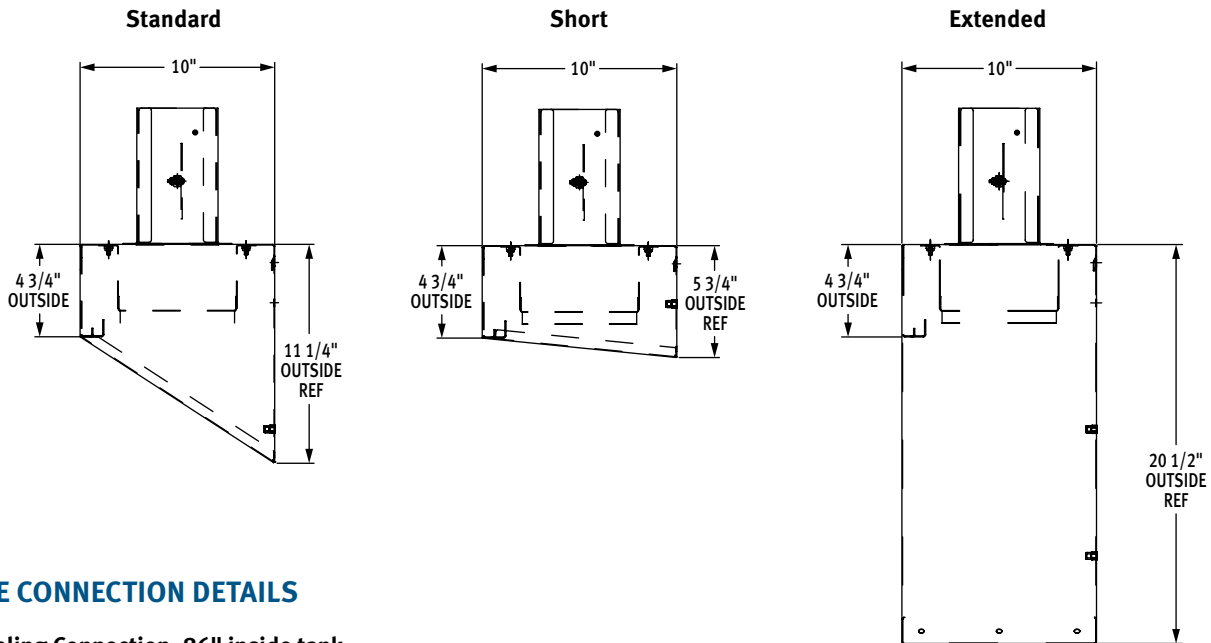
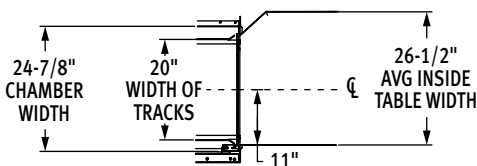
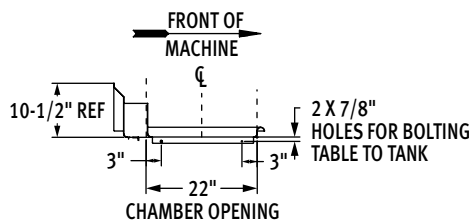

TABLE CONNECTION DETAILS

Tabling Connection: 86" inside tank (at table connection)



Suggested Track and Table Layout



View Showing Hole Locations in Turned Down Portion of Table



Sectional View Showing Table Connections

As continued product improvement is a policy of Hobart, specifications are subject to change without notice.