



Project \_\_\_\_\_  
 AIA # \_\_\_\_\_ SIS # \_\_\_\_\_  
 Item # \_\_\_\_\_ Quantity \_\_\_\_\_ C.S.I. Section 114000



## CL66-BAS STEAM

### High Temperature Rack Conveyor Dishwashing Machine



### SPECIFIER STATEMENT

Specified dishwasher will be Hobart CL66 Base steam tank heat model. Features include Complete Delime™ with Delime Notification, Auto Dispensing and Booster Guard™, capless anti-clogging wash arms, 202 racks per hour, 90 gallons per hour pumped final rinse, insulated ergonomic cabinet style doors, touchscreen controls with WiFi connectivity, and NSF approved pot and pan cycle mode. The 19.5" standard chamber height will accommodate up to (6) standard sheet pans at a time on an open-end sheet pan rack.

### STANDARD FEATURES

- + 90 gallons per hour pumped final rinse
- + 202 racks per hour
- + 22" power scrapper
- + Complete Delime™ with Delime Notification, Auto Dispensing and Booster Guard™
- + Internal stainless steel pressure-less 18 kW booster heater (70°F rise)
  - Single point electrical connection standard
- + Capless, anti-clogging wash arms
- + Self-aligning wash manifolds
- + Large double door opening for ease of cleaning
- + 19.5" chamber height opening (accepts sheet pans)
- + Doors are insulated & hinged with door interlock switches
- + User-friendly smart touchscreen controls with diagnostics & troubleshooting
- + WiFi connectivity
- + SmartConnect app with machine status, temperature logs, error code reporting, and cost, consumption and usage analysis
- + Energy saver mode (programmable auto-shut down)
- + NSF rated configurable pot and pan cycle
- + Stainless steel self-draining pump and impeller
- + Sloping scrap screens and deep scrap baskets
- + Rapid return conveyor drive mechanism
- + Service diagnostics
- + Door actuated drain closure
- + Vent fan control
- + Convertible hot water or low temperature final rinse
- + Booster heater control

### OPTIONS & ACCESSORIES (Available at extra cost)

- Standard, short and extended stainless steel vent hoods
- Non-booster
- Direct drive unloader – adds 38" length; Reference spec F48944 for more details
- Side loader – SL23 adds 23" length, SL30 adds 30" length; Reference specs F40926 and F40927 for more details
- Blower-dryer – adds 33¼" to length; Reference spec F48945 (electric blower-dryer) and F48950 (steam blower-dryer) for more details (ships separate from dishmachine, contact Hobart Service for installation)
- Drain water tempering kit
- Flanged feet kit (requires three kits)
- Higher than standard chamber (24" opening)
- External #150 steam booster heater
- Table limit switch with 20' cable
- Correctional package (factory installed, contact Hobart for details)
- Water hammer arrester
- Factory-mounted circuit breakers (contact Hobart for details)

CL SERIES – CL66-BAS STEAM

Approved by \_\_\_\_\_ Date \_\_\_\_\_ Approved by \_\_\_\_\_ Date \_\_\_\_\_



# CL66-BAS STEAM

## High Temperature Rack Conveyor Dishwashing Machine

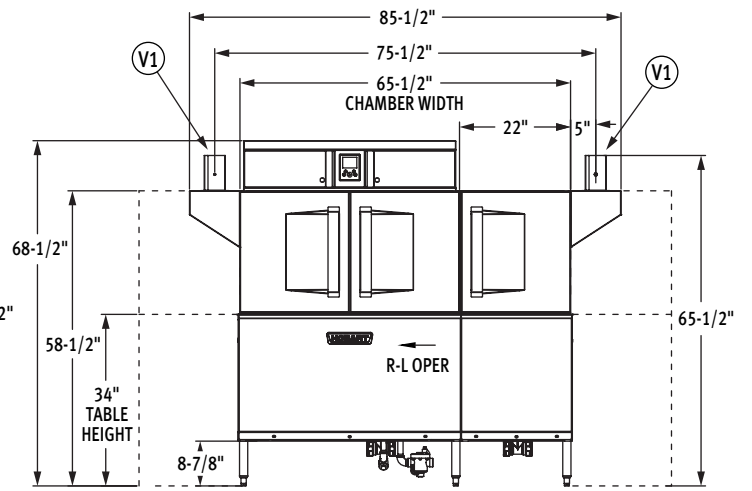
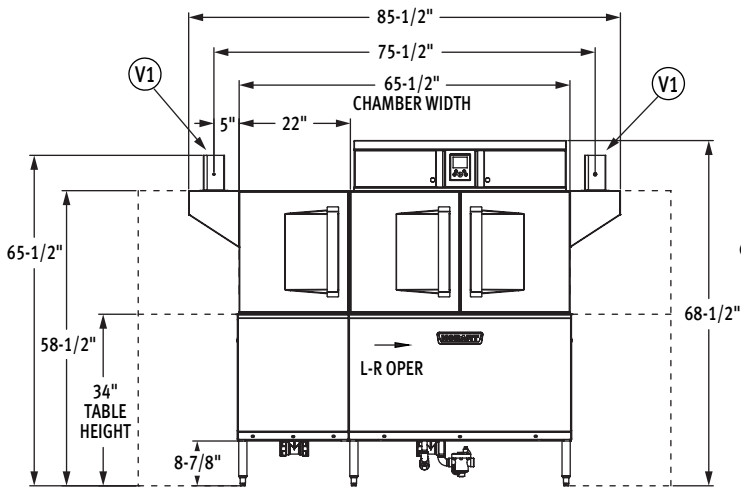
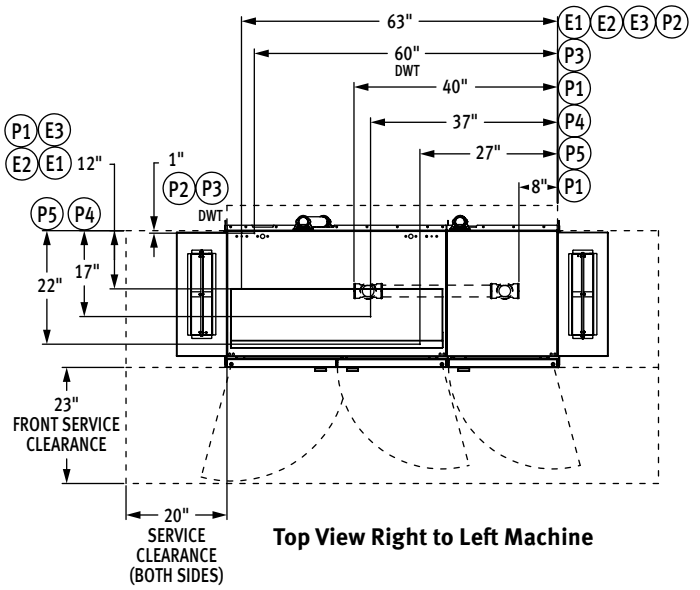
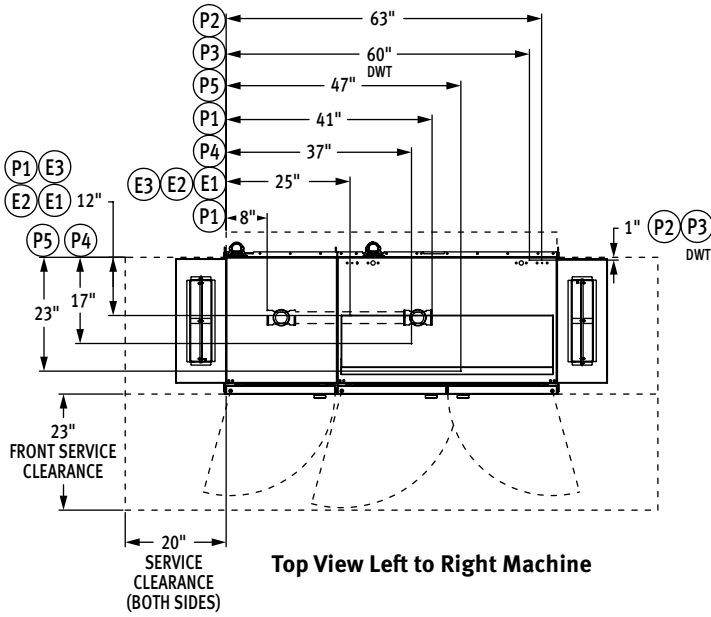

Front View Left to Right Machine

Front View Right to Left Machine

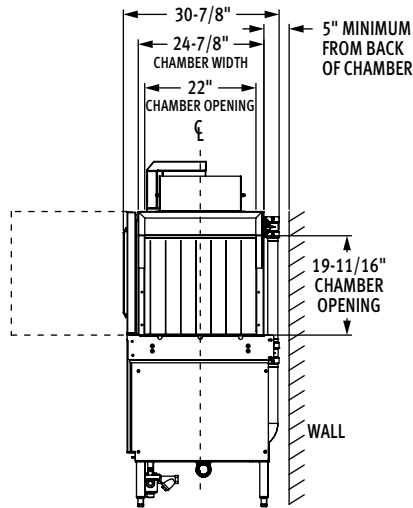

Side View

MODEL:  
CL44-BAS STEAM  
L-R OPERATION  
00-563923  
REVA

MODEL:  
CL44-BAS STEAM  
R-L OPERATION  
00-563933  
REVA



# CL66-BAS STEAM

## High Temperature Rack Conveyor Dishwashing Machine

### LEGEND

Electrical Connections	
SINGLE POINT CONNECTION	
E1	Electric connection, single point: motors, controls, with 18 kW electric booster heater, 65" AFF.
DUAL POINT CONNECTION WITH BOOSTER	
E2	Electric connection: motors, 62" AFF.
E3	Electric connection: controls, 18kW booster heater, 65" AFF.
Plumbing Connections	
P1	Drain: 2" FPT, 7-3/8" AFF, two possible connections; may be drained to either side of drain housing, plug opposite side.
P2	Common hot water connection: 1/2" FPT, 12" AFF. See plumbing notes for required temperatures.
P3	Optional drain water tempering. Cold water connection: 1/2" FPT, 12" AFF, cold temperature 80°F maximum.
P4	Steam coils: 10 to 50 PSI flowing, 3/4" FPT, 6" AFF.
P5	Condensate return: a 10 PSI minimum differential pressure across the steam trap must be maintained. 3/4" FPT, 5" AFF, one connection (one bucket type trap furnished).
Vent Connections	
V1	Optional vent hoods: 4" x 16" vent stack with damper. Load end 200 CFM, unload end 400 CFM.

### SPECIFICATIONS

#### Capacities

Racks per Hour (NSF rated)	202
Wash Tank (U.S. gallons)	23
Power Scrapper (U.S. gallons)	23
Conveyor Speed (feet per minute)	5.6

#### Motor Horsepower

Drive	1/6
Wash	2
Power Scrapper	2
Final Rinse	2/3

#### Water Consumption

U.S. Gallons per Hour	90
U.S. Gallons per Rack	0.45
Peak Drain Flow (U.S. gallons per minute)	38

#### Heating

Tank Heat, steam coils (pounds per hour)	65
Electric Booster (built-in) (kW for 70°F rise)	18
Electric Booster (field conversion) (kW for 40°F rise)	12

#### Venting

Load End (minimum CFM)	200
Unload End (minimum CFM)	400

Shipping Weight (approximate) .855 lbs.

Crated Dimensions .76"L x 38"W x 79"H

E1	Single Point Electrical Connection with Internal Booster	
Voltage	(E1) Motors, Controls, 18 kW Booster Heater	
	Rated Amps	Minimum Supply Circuit Ampacity/ Maximum Protective Device
208/60/3	70.7	90
240/60/3	62.2	80
480/60/3	33.2	40

E2	Dual Point Electrical Connection with Internal Booster (Field Conversion Only)			
E3	(E2) Motors		(E3) Controls, 18 kW Booster Heater	
Voltage	Rated Amps	Minimum Supply Circuit Ampacity/ Maximum Protective Device	Rated Amps	Minimum Supply Circuit Ampacity/ Maximum Protective Device
	208/60/3	12.2	15	58.5
240/60/3	10.4	15	51.8	70
480/60/3	6.0	15	27.2	35

**WARNING:** Electrical and grounding connections must comply with the applicable portions of the National Electrical Code and/or other local electrical codes.

**CAUTION:** Certain materials including silver, aluminum, and pewter are attacked by sodium hypochlorite (liquid bleach).

**ATTN:** Plumbing connections must comply with applicable sanitary, safety and plumbing codes.



# CL66-BAS STEAM

## High Temperature Rack Conveyor Dishwashing Machine

**Plumbing Notes:** Water hammer arrestor (meeting ASSE-1010 standard or equivalent) to be supplied (by others) in common water supply line at service connection.

Recommended water hardness to be 3 grains or less for best results.

Minimum incoming hot water temperatures:

110°F for 18kW internal booster

140°F for 12kW field converted internal booster

180°F without internal booster for high temperature sanitizing

130°F without internal booster for chemical sanitizing

Building flowing water pressure to dish machine is 20 to 65 PSI at the machine.

For convenience when cleaning, water tap should be installed near machine with heavy duty hose and squeeze valve.

For chemical sanitizing applications, feeder must be certified to NSF Standard 29.

Flowing steam pressures above 50 PSI must have a pressure regulator (by others) installed in the steam line.

Shut off valve must be supplied (by others) in the steam line to the dishwasher.

**Miscellaneous Notes:** All dimensions taken from floor line may be increased approximately 3/4" or decreased 1/2".

For HTS, add 4-5/16" to all dimensions above table line.

For HTS, add 15 lbs. to the domestic shipping weight of each model.

For optimal performance, Hobart recommends maintaining a dishroom temperature of 65°F (18°C) or higher, as lower temperatures may hinder the machine's capacity to operate effectively (with lower performance as ambient temperature decreases).

**Electrical Note:** Dishmachine not provided with internal GFCI protection.

CL66-BAS Steam Heat Dissipation		
Booster	BTU/HR.	
	Latent	Sensible
Without Booster	22,700	9,700
12kW Booster	30,800	13,200
18kW Booster	36,300	15,500

**NOTE:** 18kW Booster Heater field convertible to 12kW when 140°F incoming water provided. (Conversion instructions located in machine control box. Contact factory for 12kW booster amperage ratings.)

**NOTE:** Additional Voltages and Amperages are available, see document F48913.

### VENT HOOD OPTIONS (Adjustable, vent stack can be adjusted 1" to either side)

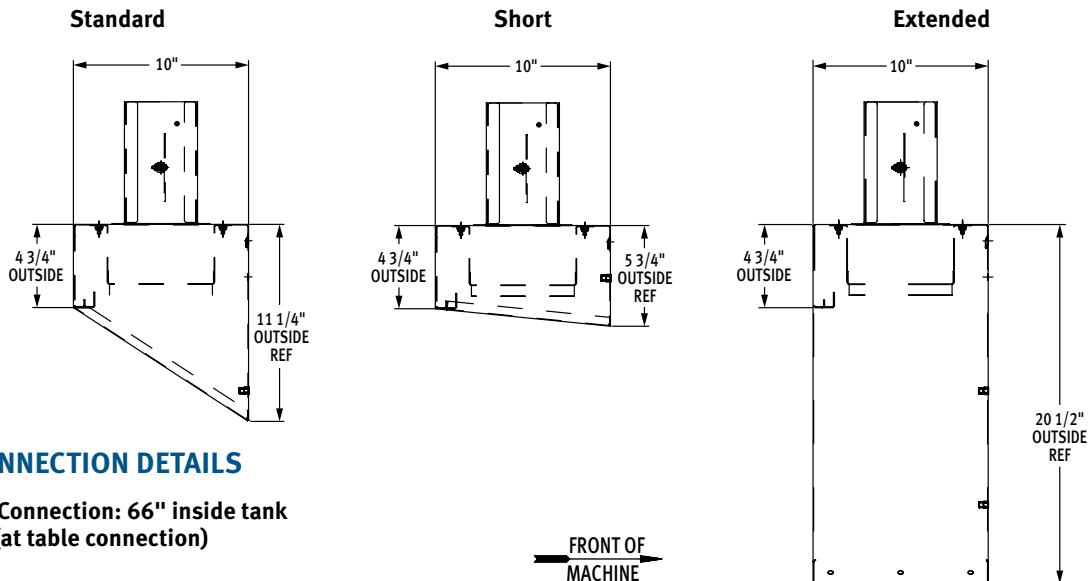

### TABLE CONNECTION DETAILS

**Tabling Connection: 66" inside tank (at table connection)**

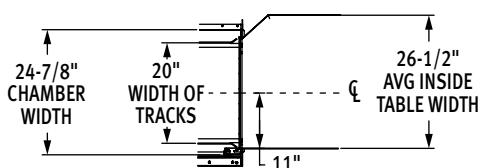

**Suggested Track and Table Layout**

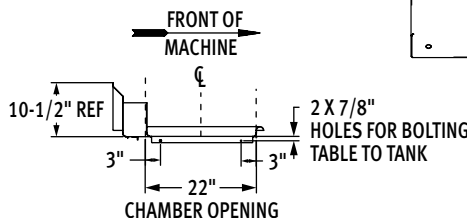

**View Showing Hole Locations in Turned Down Portion of Table**

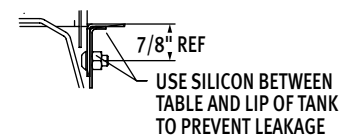

**Sectional View Showing Table Connections**

As continued product improvement is a policy of Hobart, specifications are subject to change without notice.