

KOOLAIRE®

Koolaire Ice Machines **KP & KT Series**

Installation, Operation and Maintenance Manual



Original Document

⚠ Caution

Read this instruction before operating this equipment.

Part Number: 000018481 10/25

Safety Notices

Read these precautions to prevent personal injury:

- Read this manual thoroughly before operating, installing or performing maintenance on the equipment. Failure to follow instructions in this manual can cause property damage, injury or death.
- Routine adjustments and maintenance procedures outlined in this manual are not covered by the warranty.
- Proper installation, care and maintenance are essential for maximum performance and trouble-free operation of your equipment. Visit our website www.manitowocice.com for manual updates, translations, or contact information for service agents in your area.
- This equipment contains high voltage electricity and refrigerant charge. Installation and repairs are to be performed by properly trained technicians aware of the dangers of dealing with high voltage electricity and refrigerant under pressure. The technician must also be certified in proper refrigerant handling and servicing procedures. All lockout and tag out procedures must be followed when working on this equipment.
- This equipment is intended for indoor use only. Do not install or operate this equipment in outdoor areas.

Definitions

▲ DANGER

Indicates a hazardous situation that, if not avoided, will result in death or serious injury. This applies to the most extreme situations.

▲ Warning

Indicates a hazardous situation that, if not avoided, could result in death or serious injury.

▲ Caution

Indicates a hazardous situation that, if not avoided, could result in minor or moderate injury.

Notice

Indicates information considered important, but not hazard-related (e.g. messages relating to property damage).

NOTE: Indicates useful, extra information about the procedure you are performing.

▲ Warning

Follow these precautions to prevent personal injury during installation of this equipment:

- Installation must comply with all applicable equipment fire and health codes with the authority having jurisdiction.
- To avoid instability the installation area must be capable of supporting the combined weight of the equipment and product. Additionally the equipment must be level side to side and front to back.
- Ice machines require a deflector when installed on an ice storage bin. Prior to using a non-OEM ice storage system with this ice machine, contact the bin manufacturer to assure their ice deflector is compatible.
- Prior to installing a non-OEM ice storage system with this ice machine, follow the manufacturers installation procedures and verify the location and installation meets the local/national mechanical codes and stability requirements.
- Remove all removable panels before lifting and installing and use appropriate safety equipment during installation and servicing. Two or more people are required to lift or move this appliance to prevent tipping and/or injury.
- Legs or casters must be installed and the legs/casters must be screwed in completely. When casters are installed the mass of this unit will allow it to move uncontrolled on an inclined surface. These units must be tethered/secured to comply with all applicable codes. Swivel casters must be mounted on the front and rigid casters must be mounted on the rear. Lock the front casters after installation is complete.
- Connect to a potable water supply only.
- Do not damage the refrigeration circuit when installing, maintaining or servicing the unit.
- This equipment contains refrigerant charge. Installation of the line sets must be performed by a properly trained and EPA-certified refrigeration technician aware of the dangers of dealing with refrigerant charged equipment.

⚠ DANGER



Follow these flammable refrigeration system requirements during installation, use or repair of this equipment:

- Refer to nameplate - Ice machine models may contain up to 500 grams of R290 (propane) refrigerant. R290 (propane) is flammable in concentrations of air between approximately 2.1% and 9.5% by volume (LEL lower explosion limit and UEL upper explosion limit). An ignition source at a temperature higher than 878°F (470°C) is needed for a combustion to occur. Refer to nameplate to identify the type of refrigerant in your equipment.
- To minimize the risk of ignition due to improper installation, replacement parts or service procedures, only refrigeration technicians with flammable refrigerant training who are aware of the dangers of dealing with high voltage electricity and refrigerant under pressure are allowed to work on this equipment.
- All replacement parts must be like components obtained from the equipment manufacturers authorized replacement part network.
- This equipment must be installed in accordance with the ASHRAE 15 Safety Standard for Refrigeration Systems.
- This equipment can not be installed in corridors or hallways of public buildings.
- Installation must comply with all applicable equipment fire and health codes with the authority having jurisdiction.
- Minimum room size may be required, refer to ice machine label.
- Multiple R290 units can be installed in a single room, but their cumulative refrigerant charge needs to be considered when determining the safe room size.
- All lockout and tag out procedures must be followed when working on this equipment.
- This equipment contains high voltage electricity and refrigerant charge. Shorting electrical wires to refrigeration tubing may result in an explosion. All electrical power must be disconnected from the system before servicing the system. Refrigerant leaks, can result in serious injury or death from explosion, fire, or contact with refrigerant or lubricant mists.
- Do not damage the refrigeration circuit when installing, maintaining or servicing the unit. Never use sharp objects or tools to remove ice or frost. Do not use mechanical devices or other means to accelerate the defrosting process.
- Well-ventilated areas are recommended for installation and storage.
- Leak pressure, leak hole size, wind speed, and the presence of objects like furniture within the room can also affect the concentration and distribution of R290 during a leak.

⚠ Warning

Follow these electrical requirements during installation of this equipment:

- All field wiring must conform to all applicable codes of the authority having jurisdiction. It is the responsibility of the end user to provide the disconnect means to satisfy local codes. Refer to rating plate for proper voltage.
- This appliance must be grounded.
- This equipment must be positioned so that the plug is accessible unless other means for disconnection from the power supply (e.g., circuit breaker or disconnect switch) is provided.
- Check all wiring connections, including factory terminals, before operation. Connections can become loose during shipment and installation.

⚠ DANGER

Do not operate equipment that has been misused, abused, neglected, damaged, or altered/modified from that of original manufactured specifications. This appliance is not intended for use by persons (including children) with reduced physical, sensory or mental capabilities, or lack of experience and knowledge, unless they have been given supervision concerning use of the appliance by a person responsible for their safety. Do not allow children to play with, clean or maintain this appliance without proper supervision.

⚠ Warning

Follow these precautions to prevent personal injury while operating or maintaining this equipment:

- Read this manual thoroughly before operating, installing or performing maintenance on the equipment. Failure to follow instructions in this manual can cause property damage, injury or death.
- Crush/Pinch Hazard. Keep hands clear of moving components. Components can move without warning unless power is disconnected and all potential energy is removed.
- Moisture collecting on the floor will create a slippery surface. Clean up any water on the floor immediately to prevent a slip hazard.
- Objects placed or dropped in the bin can affect human health and safety. Locate and remove any objects immediately.
- Never use sharp objects or tools to remove ice or frost. Do not use mechanical devices or other means to accelerate the defrosting process.
- When using cleaning fluids or chemicals, rubber gloves and eye protection (and/or face shield) must be worn.

⚠ DANGER

Follow these precautions to prevent personal injury during use and maintenance of this equipment:

- It is the responsibility of the equipment owner to perform a Personal Protective Equipment Hazard Assessment to ensure adequate protection during maintenance procedures.
- Do Not Store Or Use Gasoline Or Other Flammable Vapors Or Liquids In The Vicinity Of This Or Any Other Appliance. Never use flammable oil soaked cloths or combustible cleaning solutions for cleaning.
- All covers and access panels must be in place and properly secured when operating this equipment.
- Risk of fire/shock. All minimum clearances must be maintained. Do not obstruct vents or openings.
- Failure to disconnect power at the main power supply disconnect could result in serious injury or death. The power switch DOES NOT disconnect all incoming power.
- All utility connections and fixtures must be maintained in accordance with the authority having jurisdiction.
- Turn off and lockout all utilities (gas, electric, water) according to approved practices during maintenance or servicing.
- Units with two power cords must be plugged into individual branch circuits. During movement, cleaning or repair it is necessary to unplug both power cords.
- Never use a high-pressure water jet for cleaning on the interior or exterior of this unit. Do not use power cleaning equipment, steel wool, scrapers or wire brushes on stainless steel or painted surfaces.
- Two or more people are required to move this equipment to prevent tipping.
- Locking the front casters after moving is the owner's and operator's responsibility. When casters are installed, the mass of this unit will allow it to move uncontrolled on an inclined surface. These units must be tethered/secured to comply with all applicable codes.
- The on-site supervisor is responsible for ensuring that operators are made aware of the inherent dangers of operating this equipment.
- Do not operate any appliance with a damaged cord or plug. All repairs must be performed by a qualified service company.
- Do not store or use electrical appliances inside the ice machine or ice storage areas.

THIS PAGE INTENTIONALLY LEFT BLANK

Table of Contents

Section 1 General Information

Model Numbers	11
Head Sections - Air/Water/Remote Ice Machines	11
Remote Condensers.....	11
Accessories.....	12
How To Read A Model Number	13

Section 2 Installation

Location of Ice Machine.....	15
Installation Requirements.....	15
Operating Temperatures	16
Minimum Room Size.....	16
Refrigerant Charge	17
Clearance Requirements.....	17
Ice Machine Heat of Rejection.....	18
Bin Requirements	18
Dispenser Requirements.....	19
Air Baffle	20
Electrical Requirements	21
Minimum Power Cord Specifications.....	21
Maximum Breaker Size & Minimum Circuit Amperage Chart....	22
Water and Drain Connections	23
Water Supply and Drain Line Sizing/Connections	24
Connection Locations	25
Auxiliary Base Drain Installation	25
Cooling Tower Applications (Water-Cooled Models)	25
Remote Systems	26
Installation Check List	30
Before Starting the Ice Machine.....	31
Starting the Ice Machine.....	31
Warranty	31

Table of Contents (continued)

Section 3 Operation

Ice Making Sequence of Operation	33
Control Board Timers	33
Service Limits	34
Operational Checks.....	34
General	34
Minimum/Maximum Slab Weights.....	35
Ice Thickness Check	35

Section 4 Maintenance

De-scaling and Sanitizing	37
Exterior Cleaning	37
De-scaler and Sanitizer Solutions	38
Descaling Procedure	38
Sanitizing Procedure	39
Parts Removal for Descaling/Sanitizing.....	40
Remedial De-scaling Procedure.....	41
Door Removal.....	41
Cleaning the Air Filter and Condenser	42
Removal from Service/Winterization	42
General	42

Section 5 Troubleshooting

Before Calling for Service Checklist	45
Service Limit Feature	47

Section 1 General Information

Model Numbers

This manual covers the following models:

HEAD SECTIONS - AIR/WATER/REMOTE ICE MACHINES

R290 Models

Self-Contained Air-Cooled	Self-Contained Water-Cooled	Remote Air-Cooled
R290 - 22" Wide Models		
KDP0420A	KDP0420W	----
KYP0420A	KYP0420W	----
R290 - 30" Wide Models		
KDP0300A	KDP0300W	----
KYP0300A	KDY0300W	----
KDP0400A	KDP0400W	----
KYP0400A	KYP0400W	----
KDP0500A	KDP0500W	----
KYP0500A	KYP0500W	----
KDP0700A	KDP0700W	----
KYP0700A	KYP0700W	----
KDP1000A	KDP1000W	----
KYP1000A	KYP1000W	----

R410 Models

Self-Contained Air-Cooled	Self- Contained Water-Cooled	Remote Air-Cooled
R410A - 22" Wide Models		
KDT0420A	KDT0420W	----
KYT0420A	KYT0420W	----
KDT0620A	KDT0620W	----
KYT0620A	KYT0620W	----
R410A - 30" Wide Models		
KDT0500A	KDT0500W	----
KYT0500A	KYT0500W	----
KDT0700A	KDT0700W	----
KYT0700A	KYT0700W	----
KDT1000A	KDT1000W	KYT1000N
KYT1000A	KYT1000W	KDT1000N
R410A - 48" Wide Models		
KDT1700A	KDT1700W	KYT1700N
KYT1700A	KYT1700W	KDT1700N

REMOTE CONDENSERS - USED WITH REMOTE AIR-COOLED ICE MACHINES

R410A Models
JCT1200
JCT1500

Accessories

Contact your local distributor for replacement parts for accessories.

Ice Deflector

An ice deflector is required when the ice machine is installed on a bin. An ice deflector is not required when the ice machine is installed on a dispenser.

De-scaler and Sanitizer

Manitowoc De-scaler and Sanitizer are available in convenient 16 oz (473 ml) and 1 gal (3.78 l) bottles. These are the only solutions approved for use with Manitowoc products.

Arctic Pure Water Filters

Engineered specifically for Manitowoc ice machines, Arctic Pure water filters are an efficient method of inhibiting scale formation, filtering sediment, and removing chlorine taste and odor.

Top Air Discharge Kit

This kit can be used on select ice machine models. Directs warm exhaust air upward rather than out the side panels.

How To Read A Model Number

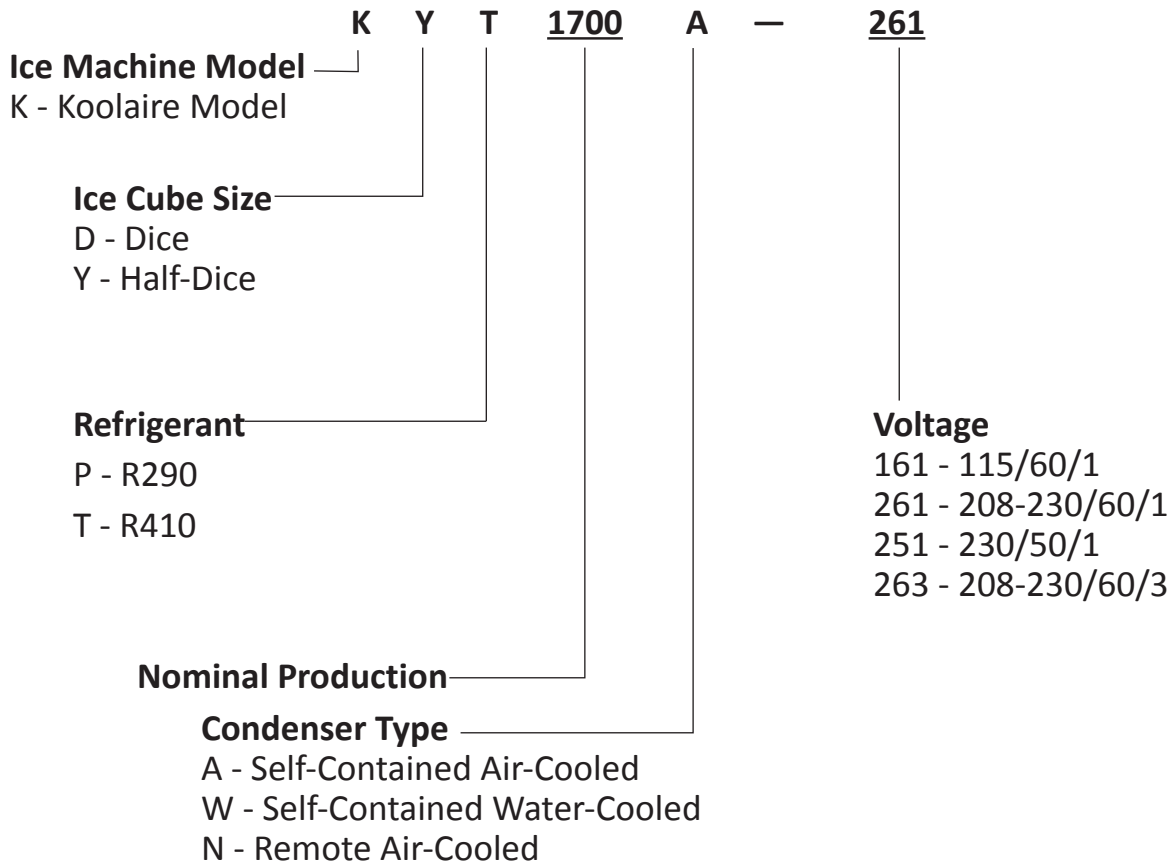

NOTE: These products are hermetically sealed and contain fluorinated greenhouse gas.

THIS PAGE INTENTIONALLY LEFT BLANK

Section 2 Installation

Location of Ice Machine

The location selected for the ice machine head section must meet the following criteria. If any of these criteria are not met, select another location.

- The location must be indoors and must be free of airborne and other contaminants.
- The location must not be near garbage or other contaminants.
- The location must not be near heat-generating equipment or in direct sunlight and protected from weather.
- The location must allow enough clearance for water, drain, and electrical connections in the rear of the ice machine.
- The location must not obstruct airflow through or around the ice machine.
- The location must be capable of supporting the weight of the ice machine and a full bin of ice.
- All utilities must be within 6 feet (2 m) of the unit for installation and serviceability.

▲Warning

Two or more people or a lifting device are required to lift this appliance.

Installation Requirements

- The ice machine and bin must be level.
- Vent the ice machine and bin drains separately.
- Bin drain termination must have an air gap.
- The ice machine and bin must be de-scaled and sanitized after installation.
- The drain line must contain a union or other suitable means of disconnection at the ice machine.

OPERATING TEMPERATURES

Model	Minimum Air Temperature	Maximum Air Temperature
All Ice Machine Head Sections	35°F 2°C	110°F 43°C

Remote Condensers	Minimum Air Temperature	Maximum Air Temperature
All Models	-20°F -29°C	120°F 49°C

Notice

The ice machine must be protected if it will be subjected to temperatures below 32°F (0°C). Failure caused by exposure to freezing temperatures is not covered by the warranty.

MINIMUM ROOM SIZE

R290 ONLY

In order to avoid the creation of a flammable gas-air mixture if a leak in the refrigeration system occurs, the size of the room in which the machine may be installed depends on the amount of refrigerant used.

The ice machines listed below cannot be installed in hallways, public corridors, public lobbies, evacuation routes and/or small spaces.

Model	Minimum Room Size sq ft (sq m)	
	Self-Contained Air-Cooled	Self-Contained Water-Cooled
KP0300	77.5 sq ft (7.2 sq m)	---
KP0400	87.0 sq ft (8.1 sq m)	77.5 sq ft (7.2 sq m)
KP0420		
KP0500	77.5 sq ft (7.2 sq m)	93 sq ft (8.6 sq m)
KP0700	159 sq ft (14.8 sq m)	159 sq ft (14.8 sq m)
KP1000	206 sq ft (19.1 sq m)	206 sq ft (19.1 sq m)

REFRIGERANT CHARGE**R290 ONLY**

Model	Self-Contained Air-Cooled	Self-Contained Water-Cooled
KP0300	5.3 oz (150 g)	---
KP0400	5.9 oz (170 g)	5.3 oz (150 g)
KP0420		
KP0500	5.3 oz (150 g)	6.5 oz (180 g)
KP0700	10.9 oz (310 g)	
KP1000	14.1 oz (400 g)	

Multiple R290 units can be installed in a single room, but their cumulative refrigerant charge needs to be considered when determining the safe room size.

CLEARANCE REQUIREMENTS**▲Warning**

Do not obstruct ice machine vents or openings.

KP0300	Self-Contained Air-Cooled	Self-Contained Water-Cooled
Top/Sides	16" (40.6 cm)	N/A
Back	5" (12.7 cm)	N/A

KT0300 KP0420	Self-Contained Air-Cooled	Self-Contained Water-Cooled
Top/Sides	12" (30.5 cm)	N/A
Back	5" (12.7 cm)	N/A

KT0400/KP0400 KT0420 KP0500/KT0500 KP0700/KT0700 KP1000/KT1000 KT1700	Self-Contained Air-Cooled	Water-Cooled and Remote*
Top/Sides	8" (20.3 cm)	8" (20.3 cm)
Back	5" (12.7 cm)	5" (12.7 cm)

KT0420 Tropical Rating 50 Hz Only	Self-Contained Air-Cooled	Water-Cooled
Top	24" (61.0 cm)	8" (20.3 cm)
Sides	12" (30.5 cm)	8" (20.3 cm)
Back	5" (12.7 cm)	5" (12.7 cm)

KT1000 Tropical Rating 50 Hz Only	Self-Contained Air-Cooled	Water-Cooled and Remote
Top	12" (30.5 cm)	8" (20.3 cm)
Sides	8" (20.3 cm)	8" (20.3 cm)
Back	5" (12.7 cm)	5" (12.7 cm)

ICE MACHINE HEAT OF REJECTION

Series Ice Machine	Heat of Rejection*	
	Air Conditioning**	Peak
KP0300		
KT0300	4600	5450
KP0400		
KT0400	3800	6000
KP0420		
KT0420	5400	6300
KP0500		
KT0500	5300	6100
KP0700		
KT0700	12400	13700
KP1000		
KT1000 60 Hz	15400	17100
KT1000 50 Hz	14600	16200
KT1700	24700	29000

* B.T.U./Hour

** Heat of rejection varies during the ice making cycle, shown is average.

^ Indicates preliminary data.

Use this information when:

- Sizing air conditioning equipment where self-contained air-cooled ice machines are installed.
- Determining the load on a cooling tower. Use the peak figure for sizing the load.

Notice

Condensers must be mounted horizontally with the fan motor on top with nothing obstructing it.

Bin Installation Requirements

- The installation area must be capable of supporting the combined weight of the equipment and product.
- All ice machines installed on a bin require an ice deflector.
- Manitowoc bins have a deflector installed and require no modifications when used with a forward-facing evaporator.
- Ice machines with multiple evaporators require a deflector kit.
- Align sides and back of ice machine with sides and back of bin when placing ice machine on bin.
- Optional sales kits are available to adapt various sized or multiple ice machines on large bins.

Bin Installation

NOTE: When using casters, the units must be tethered or secured to comply with all applicable codes. Swivel casters must be mounted on the front and rigid casters must be mounted on the rear. Lock the front casters after installation is complete.

1. Remove threaded plug from drain fitting.
2. Screw the leveling legs onto the bottom of the bin.
3. Screw the foot of each leg in as far as possible.
4. Move the bin into its final position.
5. Level the bin to assure that the bin door closes and seals properly. Use a level on top of the bin. Turn the base of each foot as necessary to level the bin.
6. Inspect bin gasket prior to ice machine installation. (Manitowoc bins come with a closed cell foam gasket installed along the top surface of the bin.)
7. Remove all panels from ice machine before lifting and installing on bin. Remove front panel, top cover, left and right side panels.

Dispenser Requirements

Observe following recommendations unless required by the dispenser manufacturer.

- The installation area must be capable of supporting the combined weight of the equipment and product.
- Dispensers requires separate electrical outlet from the ice machine.
- An adapter is not required for ice machines that match the dispenser size.
- Refer to Manitowoc “Suggested List Price Standard Equipment and Accessories” for required adapters, deflectors, and dispenser baffles. Requirements vary by model.
- Ice level management is recommended to prevent water leakage or movement of ice machine during agitation.
- Align sides and back of ice machine with sides and back of dispenser when placing ice machine.
- Front Panel must swing freely for service access.
- Follow ice machine installation procedures in this manual and any additional installation requirements specified by the dispenser manufacturer.

Air Baffle

Self-Contained Air-Cooled Only

To install:

1. Loosen the back panel screws next to the condenser.
2. Align the keyhole slots in the air baffle with the screw holes and slide the baffle down to lock in place.

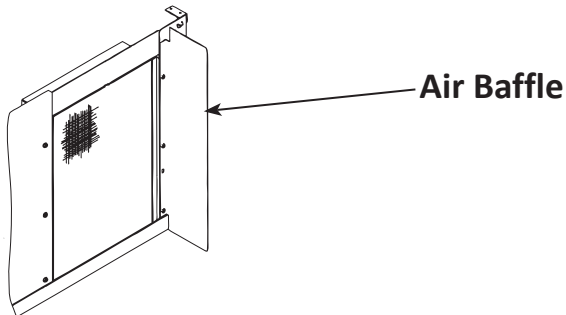

Air Gap

1. A greater than 1-inch air gap is built into the ice machine for back-flow prevention. This air gap exceeds NSF 12 requirements for back-flow prevention.

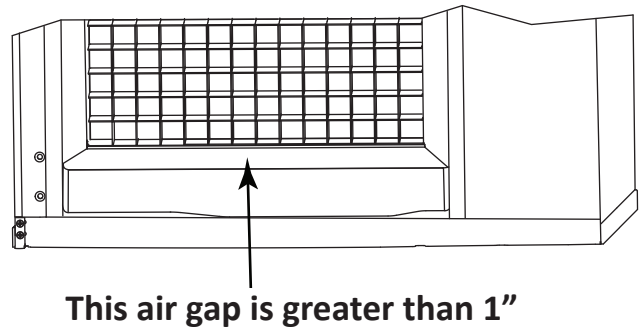

Electrical Requirements

All electrical work, including wire routing and grounding, must conform to local, state and national electrical codes. The following precautions must be observed:

- The ice machine must be grounded.
- A separate fuse/circuit breaker (dedicated circuit) must be provided for each ice machine head section, condenser or condensing unit.
- A qualified electrician must determine proper wire size (gauge) dependent upon location, materials used and length of run (minimum circuit ampacity can be used to help select the wire size).

▲Warning

All wiring must conform to local, state and national codes. The ice machine must be grounded in accordance with national and local electrical codes.

Voltage

The maximum allowable voltage variation is +10%/-5% of the rated voltage at ice machine start-up (when the electrical load is highest).

Fuse/Circuit Breaker

A separate electrical disconnect, which disconnects all poles and has 1/8" (3 mm) contact separation, must be provided for fixed wiring. Circuit breakers must be H.A.C.R. rated in USA.

Minimum Circuit Ampacity

The minimum circuit ampacity is used to help select the wire size of the electrical supply. (Minimum circuit ampacity is not the ice machine’s running amp load.)

The wire size (or gauge) also depends on location, materials used, length of run, etc., so it must be determined by a qualified electrician.

Ground Fault Circuit Interrupter

We do not recommend the use of a GFCI/GFI circuit protection with our equipment. If a GFCI/GFI is required by code, use a GFCI/GFI breaker rather than an outlet, which is more prone to intermittent nuisance trips than panel circuit breakers.

MINIMUM POWER CORD SPECIFICATIONS

Maximum Breaker Size	Minimum Wire Size	Maximum Length of Power Cord
15 amp	14 gauge	6 feet (1.83 m)
20 amp	12 gauge	6 feet (1.83 m)
30 amp	10 gauge	6 feet (1.83 m)
40 amp	8 gauge	6 feet (1.83 m)

▲Warning

Temporary electrical installations of more than 600 volts may be used only during periods of tests, emergencies, or construction-like activities.

Temporary wiring must be removed immediately upon completion of the project or purpose for which the wiring was installed.

Maximum Breaker Size & Minimum Circuit Amperage Chart

NOTE: Due to continuous product improvements, this information is for reference only. Please refer to the ice machine data plate to verify electrical data. Model/Serial data plate information overrides information listed on this page.

Ice Machine	Voltage/ Phase/ Cycle	Air-Cooled		Water-Cooled		Remote	
		Maximum Fuse/ Circuit Breaker	Minimum Circuit Amps	Maximum Fuse/ Circuit Breaker	Minimum Circuit Amps	Maximum Fuse/ Circuit Breaker	Minimum Circuit Amps
KP0300	115/1/60	15	8.2	---	---	---	---
KT0300	115/1/60	15	9.44	---	---	---	---
	230/1/50	15	4.5	---	---	---	---
	230/1/60	15	4.7	---	---	---	---
KP0400	115/1/60	15	11.4	15	10.7	---	---
KT0400	115/1/60	15	12.1	15	11.4	---	---
	230/1/50	15	6.3	15	5.9	---	---
	230/1/60	15	6.2	15	5.8	---	---
KP0420	115/1/60	20	12.0	15	11.3	---	---
KT0420	115/1/60	15	11.3	15	10.6	---	---
	230/1/50	15	6.2	15	5.8	---	---
	230/1/60	15	6.2	15	5.8	---	---
KP0500	115/1/60	20	12.5	20	11.8	---	---
KT0500	115/1/60	20	12.7	20	12.0	---	---
	230/1/50	15	6.3	15	5.9	---	---
KP0700	230/1/60	15	6.6	15	6.3	---	---
KT0700	230/1/60	15	8.5	15	8.2	---	---
	230/1/50	15	8.6	20	8.2	---	---
KP01000	230/1/60	15	8.6	15	7.9	---	---
KT1000	230/1/60	15	10.8	15	10.1	15	9.8
	230/1/50	15	11.3	---	---	---	---
KT1700	230/1/60	30	18.2	30	16.8	30	17.8
	230/3/60	20	13.6	20	12.2	20	13.2
	230/1/50	30	17.1	---	---	---	---

Water and Drain Connections

WATER CONNECTIONS

⚠ Warning

Connect to a potable water supply only. Plumbing must conform to state, local and national codes.

- Local water conditions may require treatment of the water to inhibit scale formation, filter sediment, and remove chlorine odor and taste.
- All water and drains must conform to all applicable codes of the authority having jurisdiction. It is the responsibility of the end user to satisfy all local codes.
- Connect ice making water inlet to potable water only.
- Install a water shut-off valve for potable water and water cooled condenser lines.
- Install a water regulating valve if water pressure exceeds the maximum valve rating.
- Insulate water and drain lines to prevent condensation.
- If you are installing a water filter system, refer to the installation instructions supplied with the filter system for ice making water inlet connections.
- Do not connect the ice machine to a hot water supply. Be sure all hot water restrictors installed for other equipment are working. (Check valves on sink faucets, dishwashers, etc.)

⚠ Caution

Do not apply heat to water inlet valve or water drain fittings. Heating will damage the nonmetallic connector. Do not over tighten fittings. Two turns after hand tight is the maximum.

DRAIN CONNECTIONS

Follow these guidelines when installing drain lines to prevent drain water from flowing back into the ice machine and storage bin:

- Drain lines must have a 1.5 inch drop per 5 feet of run (2.5 cm per meter), and must not create traps.
- The floor drain must be large enough to accommodate drainage from all drains.
- Run separate bin and ice machine drain lines. Insulate them to prevent condensation.
- Vent the bin and ice machine drain to the atmosphere. Do not vent the condenser drain on water-cooled models.
- Install a tee at the ice machine drain outlet and install an 18.0" (46 cm) vent above the drain line.
- Drain termination must have an air gap that meets local code. Water Supply and Drain Line Sizing/Connections

Water Supply and Drain Line Sizing/ Connections

Location	Water Temperature	Water Pressure	Ice Machine Fitting	Tubing Size Up to Ice Machine Fitting
Ice Making Water Inlet	35°F (2°C) Min. 90°F (32°C) Max.	20 psi (140 kPa) Min. 80 psi (552 kPa) Max.	3/8" (.95 cm) Female Pipe Thread	3/8" (.95 cm) min. inside diameter
Ice Making Water Drain	–	–	1/2" (1.27 cm) Female Pipe Thread	1/2" (1.27 cm) min. inside diameter
Condenser Water Inlet	90°F (32°C) Max.	Standard 20 psi (140 kPa) Min. 275 psi (1896 kPa) Max. High Pressure Option 20 psi (140 kPa) Min. 350 psi (2410 kPa) Max.	3/8" Female Pipe Thread	
Condenser Water Drain	–	–	1/2" (1.27 cm) Female Pipe Thread	1/2" (1.27 cm) min. inside diameter
Bin Drain	–	–	3/4" (1.91 cm) Female Pipe Thread	3/4" (1.91 cm) min. inside diameter
Large Capacity Bin Drain	–	–	1" (2.54 cm) Male Pipe Thread	1" (2.54 cm) min. inside diameter

Min. = Minimum, Max. = Maximum

CONNECTION LOCATIONS

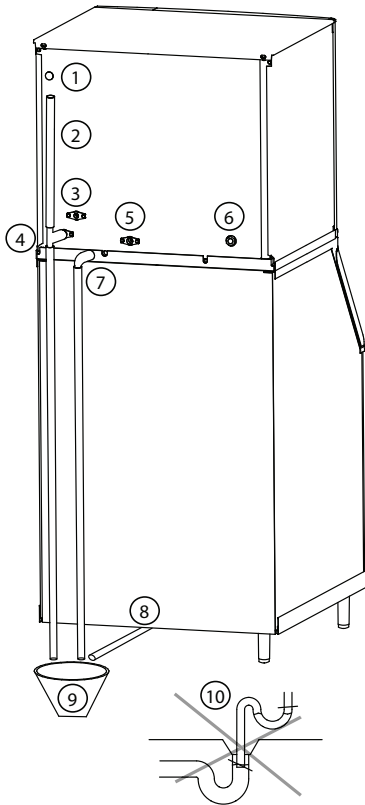

Item	Description
1	Electrical Entrance
2	Vent Tube - Minimum Height 18" (46 cm)
3	Potable Water Inlet - 3/8" FPT
4	Potable Water Drain - 1/2" FPT
5	Condenser Water Drain - 1/2" FPT Water-cooled Models Only Install Separate Drain When Used
6	Condenser Water Inlet - 3/8" FPT Water-cooled Models Only
7	Base Drain - 1/2" CPVC Socket
8	Bin Drain - See page 23 for fitting sizes
9	Floor Drain - Open and Trapped
10	Do Not Trap Drain Line - Leave Air Gap Between Drain Line and Floor Drain

AUXILIARY BASE DRAIN INSTALLATION

An auxiliary drain is located in the ice machine base to remove moisture in high humidity areas.

1. View the back of the ice machine base on the compressor side and locate and remove the cap plug.
2. Route tubing to an open site drain:
 - Use 1/2 inch CPVC tubing.
 - Apply a bead of silicone around the exterior of the ice machine tubing and insert into ice machine base. The silicone will secure the tubing and provide a watertight seal.
 - Provide support for tubing.

COOLING TOWER APPLICATIONS (WATER-COOLED MODELS)

A water cooling tower installation does not require modification of the ice machine.

- Water pressure at the condenser cannot exceed 276 psig (1900 kPa).
- Water entering the condenser must not exceed 90°F (32°C).
- Water flow through the condenser must not exceed 5 gallons (19 liters) per minute.
- Allow for a pressure drop of 7 psi (50 kPa) between the condenser water inlet and the outlet of the ice machine.
- Water exiting the condenser must not exceed 110°F (43°C). Remote Ice Machines

Remote Systems

REFRIGERANT CHARGE

Each remote ice machine ships from the factory with a refrigerant charge appropriate for installation with line sets of up to 50' (15 m). The serial tag on the ice machine indicates the refrigerant charge.

Additional refrigerant may be required for installations using line sets between 51' and 100' (15.5-30 m) long. If additional refrigerant is required, refer to the chart below for the correct amount to be added.

Ice Machine	Refrigerant to be added for 51'-100' Line Sets
KT1000	2 lbs (907g)
KT1700	2 lbs (907g)

Important

EPA CERTIFIED TECHNICIANS

If remote line set length is between 51' and 100' (15.5 and 30 m), add additional refrigerant to the nameplate charge. Refer to the table below for the model being worked on.

Tubing length: _____

Refrigerant added to nameplate: _____

New total refrigerant charge: _____

⚠ Warning

Potential Personal Injury Situation

The ice machine contains refrigerant charge. Installation of the line sets must be performed by a properly trained and EPA certified refrigeration technician aware of the **dangers of dealing with refrigerant charged equipment.** "

GENERAL

Condensers must be mounted horizontally with the fan motor on top with nothing obstructing it. There must be at least a 16" (41 cm) clearance from the bottom for air intake. The front coupling panel and one other panel (back or side) must also be unobstructed.

Remote condenser installations consist of vertical and horizontal line sets between the ice machine and the condenser. When combined, they must fit within approved specifications. The following guidelines, drawings and calculation methods must be followed to verify a proper remote condenser installation.

Notice

The compressor warranty (including the labor replacement warranty) will not apply if the remote ice machine is not installed according to specifications.

The warranty also will not apply if the refrigeration system is modified with a condenser, heat reclaim device, or other parts or assemblies not manufactured by us unless we specifically approved the component in writing.

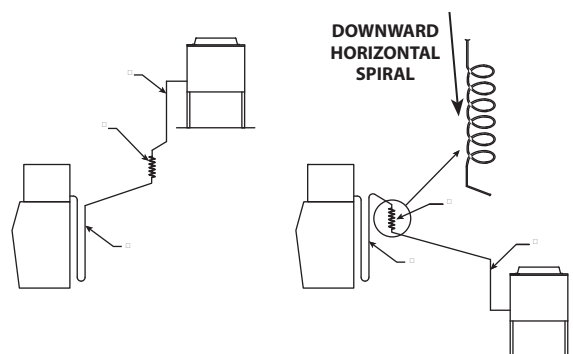

Routing Line Sets

WIRING

Interconnecting line voltage wiring is used to energize and de-energize the condenser fan motor.

- The remote condenser voltage matches the ice machine head section voltage.

Interconnecting Wire Connections	
Ice Machine Head Section	Remote Condenser
F1	L1
F2	L2

GUIDELINES FOR ROUTING LINE SETS

First, cut a 2.5" (6.35 cm) circular hole in the wall or roof for tubing routing. The line set end with the 90° bend will connect to the ice machine. The straight end will connect to the remote condenser.

Follow these guidelines when routing the refrigerant lines. This will help ensure proper performance and service accessibility.

1. Optional - Make the service loop in the line sets (as shown in Routing Line Sets graphic). This permits easy access to the ice machine for cleaning and service. Do not use hard rigid copper at this location.
2. Required - Do not form traps in the refrigeration lines (except the service loop). Refrigerant oil must be free to drain toward the ice machine or the condenser. Route excess tubing in a supported downward horizontal spiral (as shown below). Do not coil tubing vertically.
3. Required - Keep outdoor refrigerant line runs as short as possible.

CALCULATING REMOTE CONDENSER INSTALLATION DISTANCES**Line Set Length**

The maximum length is 100' (30 m).

The ice machine compressor must have the proper oil return. The receiver is designed to hold a charge sufficient to operate the ice machine in ambient temperatures between -20°F (-29°C) and 120°F (49°C), with line set lengths of up to 100' (30 m).

Line Set Rise/Drop

The maximum rise is 35' (10.7 m).

The maximum drop is 15' (4.5 m).

Notice

If a line set has a rise followed by a drop, another rise cannot be made. Likewise, if a line set has a drop followed by a rise, another drop cannot be made.

Calculated Line Set Distance

The maximum calculated distance is 150' (45 m).

Line set rises, drops, horizontal runs (or combinations of these) in excess of the stated maximums will exceed compressor start-up and design limits. This will cause poor oil return to the compressor.

Make the following calculations to make sure the line set layout is within specifications.

1. Insert the **measured rise** into the formula below. Multiply by 1.7 to get the **calculated rise**.
(Example: A condenser located 10 feet above the ice machine has a **calculated rise** of 17 feet.)
2. Insert the **measured drop** into the formula below. Multiply by 6.6 to get the **calculated drop**.
(Example. A condenser located 10 feet below the ice machine has a **calculated drop** of 66 feet.)

3. Insert the **measured horizontal distance** into the formula below. No calculation is necessary.
4. Add together the **calculated rise**, **calculated drop**, and **horizontal distance** to get the **total calculated distance**. If this total exceeds 150' (45 m), move the condenser to a new location and perform the calculations again.

Maximum Line Set Distance Formula

- Step 1. Measured Rise (35' [10.7 m] Maximum) x 1.7 = Calculated Rise
- Step 2. Measured Drop (15' [4.5 m] Maximum) x 6.6 = Calculated Drop
- Step 3. Measured Horizontal Distance (100' [30 m] Maximum) = Horizontal Distance
- Step 4. Total Calculated Distance 150' (45 m) _____ Total Calculated Distance

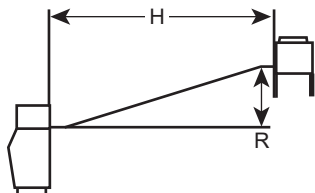

Combination of a Rise (R) and a Horizontal (H) Run

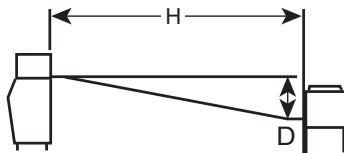

Combination of a Drop (D) and a Horizontal (H) Run

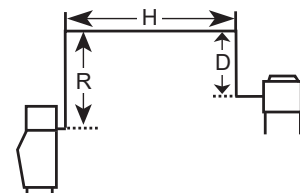

Combination of a Rise (R), a Drop (D) and a Horizontal (H) Run

Route the Line Set

- Route the line set to avoid traps and kinks.
- Minimize the amount of line set exposed on the roof.

Connect the line Set

In most cases, by routing the line set properly, shortening will not be necessary. When shortening or lengthening is required, do so before connecting the line set to the ice machine or the remote condenser. This prevents the loss of refrigerant in the ice machine or condenser.

The quick connect fittings on the line sets are equipped with access valves. Use these valves to recover any vapor charge from the line set. When lengthening or shortening lines, follow good refrigeration practices, purge with nitrogen and insulate all tubing. Do not change the tube sizes. Evacuate the lines and place about 145 grams (5 oz) of vapor refrigerant charge in each line.

1. Remove the dust caps from the line set, condenser and ice machine.
2. Apply refrigeration oil to the threads on the quick-disconnect couplers before connecting them to the condenser.

3. Carefully thread the female fitting to the condenser or ice machine by hand, then tighten the couplings with a wrench until they bottom out.
4. Turn an additional quarter turn to ensure proper brass-to-brass seating. Torque to the following specifications:

Liquid Line	Discharge Line
13.5-16.2 N•m	47.5-61.0 N•m

5. Check all fittings and valve caps for leaks and reinstall and tighten caps.

Installation Check List

- Is the Ice Machine level?
- Have all of the electrical and water connections been made?
- Has the supply voltage been tested and checked against the rating on the nameplate?
- Is there proper clearance around the ice machine for air circulation?
- Is the ice machine grounded and polarity correct?
- Has the ice machine been installed where ambient temperatures will remain in the range of 35° - 110°F (1.6° - 43.3°C)?
- Has the ice machine been installed where the incoming water temperature will remain in the range of 35° - 90°F (1.6° - 32.2°C)?
- Is there a separate drain for the potable water, bin and water-cooled condenser?
- Are the ice machine and bin drains vented?
- Are all refrigerant lines free from contact with other components?
- Are all electrical leads free from contact with refrigeration lines and moving equipment?
- Has the owner/operator been instructed regarding maintenance and the use of our Cleaner and Sanitizer?
- Has the owner/operator completed the warranty registration card?
- Has the ice machine and bin been sanitized?
- Is the ice thickness set correctly? (Refer to Operational Checks to check/set the correct ice bridge thickness).

ADDITIONAL CHECKS FOR REMOTE MODELS

- Does the remote condenser fan operate properly after start-up?
- Has the remote condenser been located where ambient temperatures will remain in the range of -20° - 120°F (-29 - 49°C).
- Is the line set routed properly?
- Are both refrigeration lines to remote condenser run so they do not lay in water and are properly insulated?

Before Starting the Ice Machine

All ice machines are factory-operated and adjusted before shipment. Normally, new installations do not require any adjustment. Starting the ice machine and completing the Operational Check-s are the responsibilities of the owner/operator.

Step 1 Refer to “Location of Ice Machine” on page 15 and sanitize the ice machine and bin before placing in operation.

Step 2 Refer to “Ice Making Sequence of Operation” on page 33 for operational details.

▲ Warning

Potential Personal Injury Situation

Do not operate equipment that has been misused, abused, neglected, damaged, or altered/modified from that of original manufactured specifications.

Starting the Ice Machine

Starting the ice machine and completing the Operational Checks are the responsibilities of the owner/operator.

Adjustments and maintenance procedures outlined in this manual are not covered by the warranty.

MINIMUM/MAXIMUM SLAB WEIGHT

“Minimum/Maximum Slab Weights” on page 35.

Warranty

For warranty information visit:

www.manitowocice.com/Service/Warranty

- Warranty Coverage Information
- Warranty Registration
- Warranty Verification

Warranty coverage begins the day the ice machine is installed.

WARRANTY REGISTRATION

Completing the warranty registration process is a quick and easy way to protect your investment.

Scan the QR code on the included tag with your smart device or enter the link in a web browser to complete your warranty registration.

WWW.MANITOWOCICE.COM/SERVICE/WARRANTY#WARRANTY-REGISTRATION

Registering your product ensures warranty coverage and streamlines the process if any warranty work is required.

To obtain a printed copy of warranty terms, please contact Manitowoc Ice at 800-545-5720.

THIS PAGE INTENTIONALLY LEFT BLANK

Section 3 Operation

Ice Making Sequence of Operation

NOTE: The toggle switch must be in the ICE position and the water curtain must be closed before the ice machine will start.

Water Purge Cycle

The ice machine purges any remaining water from the water trough down the drain and the refrigeration compressor starts.

Freeze Cycle

Prechill - The refrigeration system chills the evaporator before water flow over the evaporator starts. The water inlet valve energizes during the pre-chill and remains on until the Ice Thickness Float Switch is satisfied.

Freeze - Water flowing across the evaporator freezes and builds ice on the evaporator. After a sheet of ice has formed, the Harvest Float Switch signals the control board to start a harvest cycle.

Dump Cycle

Upon initial start-up or start-up after an auto shut-off, water flows through the water dump valve and down the drain. If the water trough fails to drain after the water dump valve has energized/de-energized, a clean light will flash.

Harvest Cycle

Any remaining water is purged down the drain (every fourth cycle) as refrigerant gas warms the evaporator. When the evaporator warms, the sheet of cubes slides off the evaporator and into the storage bin. If all cubes fall clear of the water curtain, the ice machine starts another freeze cycle.

Full Bin Cycle

If the water curtain is held open by ice cubes, the ice machine shuts off and starts a 3-minute delay period. When the water curtain closes, the ice machine starts a new cycle at the water purge, provided the 3-minute delay period has expired.

CONTROL BOARD TIMERS

The control board has the following non-adjustable timers:

- The ice machine is locked into the freeze cycle for 6 minutes before a harvest cycle can be initiated.
- The maximum freeze time is 35 minutes, at which time the control board automatically initiates a harvest sequence.
- The maximum harvest time is 7 minutes. The control board automatically initiates a freeze sequence when these times are exceeded.

SERVICE LIMITS

Service limits are stored and indicated by the control board. The number of cycles required to stop the ice machine varies for each service limit.

Service limits can be reset by pressing the On/Off button and starting a new ice making cycle.

A service limit is indicated by a flashing Service Light on the control board.

- Service Limit 1 - If the freeze time reaches 35 minutes, the control board automatically initiates a harvest cycle. If 6 consecutive 35-minute freeze cycles occur, the ice machine stops.
- Service Limit 2 - If three consecutive 7 minute harvest cycles occur the SL#2 light on the control board will flash on/off at 1 second intervals. After 100 consecutive 7 minutes harvest cycles the SL#2 light will be energized continuously.
- Water Loss - If the water trough doesn't fill within 4 minutes of the freeze cycle, the ice machine will stop for 30 minutes then restart. If 100 consecutive failures occur the ice machine locks out and the SL#1 & SL#2 lights flash on/off at 1 second intervals.

Operational Checks

GENERAL

All ice machines are factory-operated and adjusted before shipment. Normally, new installations do not require any adjustment.

To ensure proper operation, always follow the Operational Checks:

- when starting the ice machine for the first time
- after a prolonged out-of-service period
- after cleaning and sanitizing

NOTE: Routine adjustments and maintenance procedures are not covered by the warranty.

MINIMUM/MAXIMUM SLAB WEIGHTS

Adjust ice thickness to meet chart specifications.

Model	Minimum Ice Weight Per Cycle	Maximum Ice Weight Per Cycle
KP0300 KT0300	3.4 lbs 1542 g	3.9 lbs 1769 g
KP0400 KT0400	3.4 lbs 1542 g	3.9 lbs 1769 g
KP0420 KT0420	3.4 lbs 1542 g	3.9 lbs 1769 g
KP0500 KT0500	4.125 lbs 1871 g	4.75 lbs 2154 g
KP0700 KT0700	4.125 lbs 1871 g	4.75 lbs 2154 g
KP1000 KT1000	7.25 lbs 3288 g	7.75 lbs 3515 g
KT1700	13.2 lbs 5987 g	14.8 lbs 6713 g

ICE THICKNESS CHECK

After a harvest cycle, inspect the ice cubes in the ice storage bin. The ice thickness float switch is factory-set to maintain the ice bridge thickness at 1/8" (3 mm).

NOTE: Make sure the water curtain is in place when performing this check. It prevents water from splashing out of the water trough.

1. Inspect the bridge connecting the cubes. It should be about 1/8" (3 mm) thick.
2. If adjustment is necessary make the following adjustment as you face the machine.

NOTE: The float can be adjusted with a 3/4" wrench while the water trough is in place.

- Turn the ice thickness float switch to the right to increase bridge thickness
- Turn the ice thickness float switch to the left to decrease bridge thickness.
- Test run two cycles to verify bridge thickness.

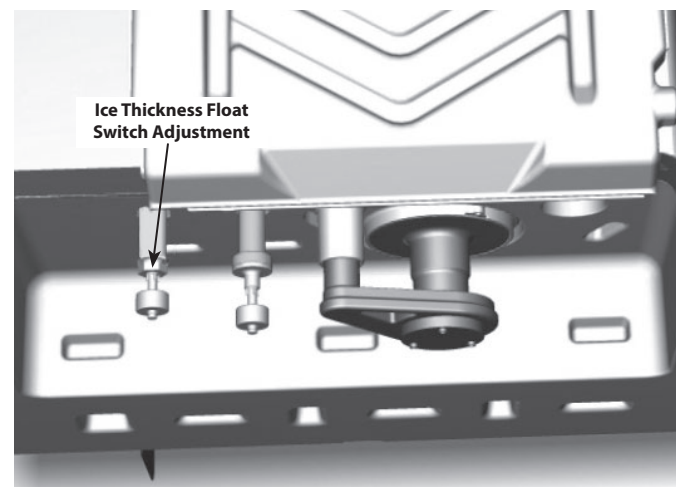

THIS PAGE INTENTIONALLY LEFT BLANK

Section 4 Maintenance

De-scaling and Sanitizing

GENERAL

You are responsible for maintaining the ice machine in accordance with the instructions in this manual. Maintenance procedures are not covered by the warranty.

Sanitizing for Exterior, Remedial, and Detailed procedures can be performed independently and more frequently than de-scaling when needed.

De-scale and sanitize the ice machine every six months for efficient operation. If the ice machine requires more frequent de-scaling and sanitizing, consult a qualified service company to test the water quality and recommend appropriate water treatment. An extremely dirty ice machine must be taken apart for de-scaling and sanitizing.

Manitowoc Ice Machine De-scaler and Sanitizer are the only products approved for use in Manitowoc ice machines.

Using non Manitowoc de-scalers, sanitizers, cleaners or solutions may result in bodily harm and/or cause damage to the ice machine that is not covered under the warranty.

Ice Machine Inspection

Check all water fittings and lines for leaks. Also, confirm refrigeration tubing is not rubbing or vibrating against other tubing, panels, etc.

Do not put anything (boxes, etc.) in front of the ice machine. There must be adequate airflow through and around the ice machine to maximize ice production and ensure long component life.

Exterior Cleaning

Clean the area around the ice machine as often as necessary to maintain cleanliness and efficient operation.

Wipe surfaces with a damp cloth rinsed in water to remove dust and dirt from the outside of the ice machine. If a greasy residue persists, use a damp cloth rinsed in a mild dish soap and water solution. Wipe dry with a clean, soft cloth.

Products containing abrasives will damage the coating and scratch the panels.

- Never use steel wool or abrasive pads for cleaning.
- Never use chlorinated, citrus based or abrasive cleaners on exterior panels and plastic trim pieces.

Remedial De-scaling Procedure

- This procedure de-scales all components in the water flow path, and is used between the bi-yearly detailed de-scaling and sanitizing procedure.

Detailed De-scaling/Sanitizing Procedure

This procedure must be performed a minimum of once every six months.

- The ice machine and bin must be disassembled de-scaled and sanitized.
- All ice produced during the de-scaling and sanitizing procedures must be discarded.

Caution

Do not mix De-scaler and Sanitizer solutions together. It is a violation of Federal law to use these solutions in a manner inconsistent with their labeling.

Warning

Wear rubber gloves and safety goggles (and/or face shield) when handling Ice Machine De-scaler or Sanitizer.

De-scaler and Sanitizer Solutions

Caution

Use only Manitowoc approved Ice Machine De-scaler and Sanitizer for this application. Do not use de-scaler or sanitizer quantities that exceed the amounts listed in this manual. It is a violation of Federal law to use these solutions in a manner inconsistent with their labeling. Read and understand all labels printed on bottles before use.

Liquid De-scaler	Liquid Sanitizer
16 oz - 9405463	16 oz - 9405653
1 gal - 9405803	1 gal - 9405813

NOTE: Powdered de-scaler and rinse are available. Please follow the instructions included with the packets for number of packets needed for your model

Step 1 Remove the front door to access the evaporator compartment. Ice must not be on the evaporator during the clean/sanitize cycle. Set the toggle switch to the OFF position after ice falls from the evaporator at the end of a harvest cycle. Or, set the switch to OFF and allow the ice to melt off the evaporator(s).

Notice

Never use anything to force ice from the evaporator. Damage may result.

Step 2 Remove all ice from the bin/dispenser.

Step 3 Place the toggle switch in the CLEAN position. Water will flow through the water dump valve and down the drain. Wait until the water trough refills, then add the proper amount of ice machine descaler.

Model	Amount of De-scaler 9405463
K0300 K0400 K0420 K0500 K0700 K1000	5 ounces (150 ml)
K1700	9 ounces (265 ml)

Step 4 Wait until the clean cycle is complete (approximately 30 minutes). Then disconnect power to the ice machine (and dispenser when used).

Warning

Disconnect the electric power to the ice machine at the electric service switch box.

Step 5 Remove parts for descaling.

Please refer to parts removal and continue with step 6 when the parts have been removed - Refer to page 40.

Step 6 Mix a solution of descaler and lukewarm water. Depending upon the amount of mineral buildup, a larger quantity of solution may be required. Use the ratio in the table below to mix enough solution to thoroughly clean all parts.

Solution Type	Water	Mixed with
Liquid De-scaler 9405463	1 gal (4 L)	16 oz (500 ml) descaler

Step 7 Use half of the descaler/water mixture to clean all components. The descaler solution will foam when it contacts lime scale and mineral deposits; once the foaming stops use a soft-bristle nylon brush, sponge or cloth (NOT a wire brush) to carefully clean the parts. Soak parts for 5 minutes (15-20 minutes when heavily scaled). Rinse all components with clean water.

Step 8 While components are soaking, use half of the descaler/water solution to clean all foodzone surfaces of the ice machine and bin (or dispenser). Use a nylon brush or cloth to thoroughly clean the following ice machine areas:

- Evaporator plastic parts – including top, bottom and sides
- Bin bottom, sides and top

Rinse all areas thoroughly with clean water.

SANITIZING PROCEDURE

Step 9 Mix a solution of sanitizer and lukewarm water.

Solution Type	Water	Mixed with
Liquid Sanitizer 9405463	3 gal. (12 L)	2 oz (60 ml) sanitizer

Step 10 Use half of the sanitizer/water solution to sanitize all removed components. Use a spray bottle to liberally apply the solution to all surfaces of the removed parts or soak the removed parts in the sanitizer/water solution. Do not rinse parts after sanitizing.

Step 11 Use half of the sanitizer/water solution to sanitize all foodzone surfaces of the ice machine and bin (or dispenser). Use a spray bottle to liberally apply the solution. When sanitizing, pay particular attention to the following areas:

- Evaporator plastic parts - including top, bottom and sides
- Ice machine base (top of bin) and area above the water trough
- Bin sides and bottom

Do not rinse the sanitized areas.

Step 12 Replace all removed components.

Step 13 Wait 20 minutes.

Step 14 Reapply power to the ice machine and place the toggle switch in the CLEAN position.

Step 15 Wait until the water trough refills, then add the proper amount of Manitowoc Ice Machine Sanitizer to the water trough.

Model	Amount of Liquid Sanitizer 9405653
K0300 K0400 K0420 K0500 K0700 K1000	3 ounces (90 ml)
K1700	6 ounces (180 ml)

Step 16 After the sanitize cycle is complete (approximately 24 minutes) move the toggle switch to the ICE position to start ice making.

Notice

Electrical connector must never be exposed to any liquids.

Parts Removal for Descaling/ Sanitizing

Single Evaporator Ice Machines

A. Remove the water curtain

- Gently flex the curtain in the center and remove it from the right side.
- Slide the left pin out.

B. Remove the water trough and water diverter from the bottom of the evaporator.

- Depress tabs on right and left side of the water trough.
- Allow front of water trough to drop as you pull forward to disengage the rear pins.
- Loosen thumbscrew on left side of waterdiverter tray.

C. Remove the ice thickness and harvest float switches

- Pull the float switch straight down to disengage.
- Lower the float switch until the wiring connector is visible.
- Disconnect the wire lead from the float switch.
- Remove the float switch from the ice machine.

D. Remove the water distribution tube

NOTE: Distribution tube thumbscrews are retained to prevent loss. Loosen thumbscrews but do not pull thumbscrews out of distribution tube.

- Loosen the two outer screws (do not remove screws completely they are retained to prevent loss) and pull forward on the distribution tube to release from slip joint.
- Disassemble distribution tube by loosening the two (2) middle thumbscrews and dividing the distribution tube into two pieces.
- Proceed to page 34 Step 6.

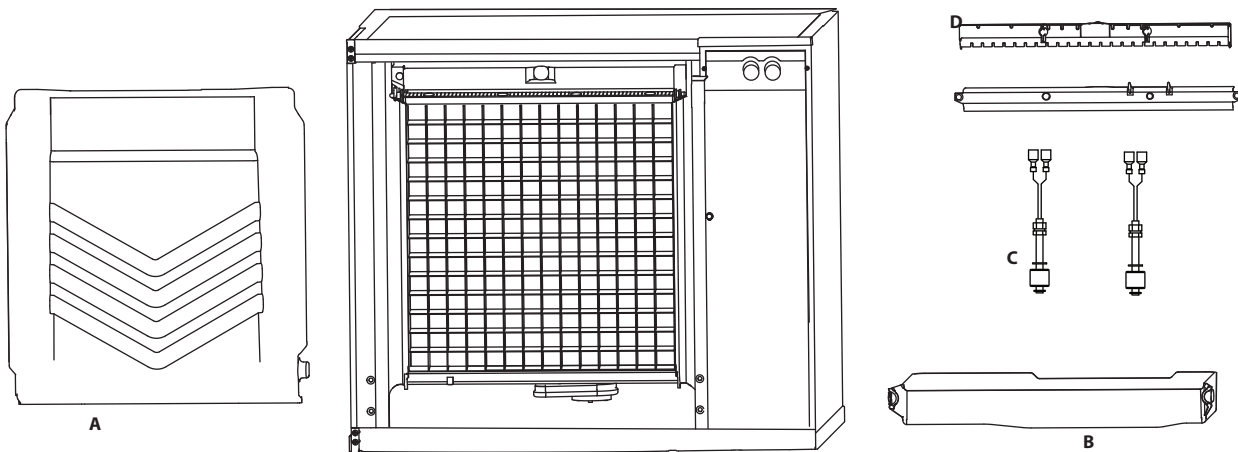

Remedial De-scaling Procedure

This procedure de-scales all components in the water flow path, and is used to de-scale the ice machine between the bi-yearly detailed de-scaling and sanitizing procedure.

Ice machine de-scaler is used to remove lime scale and mineral deposits. Ice machine sanitizer disinfects and removes algae and slime.

NOTE: Although not required and dependent on your installation, removing the ice machine top cover may allow easier access.

Step 1 Ice must not be on the evaporator during the clean/sanitize cycle. Follow one of the methods below:

- Move the toggle switch to the OFF position at the end of a harvest cycle after ice falls from the evaporator(s).
- Move the toggle switch to the OFF position and allow the ice to melt.

Notice

Never use anything to force ice from the evaporator. Damage may result.

Step 2 Open the front door and move the toggle switch to the CLEAN position. Wait until the water trough refills (approximately 1 minute) and then add the proper amount of Ice Machine Descaler to the water trough.

Model	Amount of Descaler 9405463
K0300 K0400 K0420 K0500 K0700 K1000	5 oz (150 ml)
K1700	9 oz (265 ml)

Step 3 After 1 minute place the toggle switch in the ICE position and close and secure the front door. The ice machine will automatically start ice making after the Clean cycle is complete (approximately 24 minutes).

Door Removal

1. Use a Phillips screwdriver to loosen the two screws securing the door. Do not remove, they are retained to prevent loss.
2. Tilt door forward and lift up to remove.

Cleaning the Air Filter and Condenser

The washable filter on self-contained ice machines is designed to catch dust, dirt, lint and grease. Clean the filter once a month with mild soap and water.

A dirty condenser restricts airflow, resulting in excessively high operating temperatures. This reduces ice production and shortens component life.

Warning

Disconnect electric power to the ice machine head section and the remote condensing unit at the electric service switches before cleaning the condenser.

- Clean the condenser at least every six months.
- Shine a flashlight through the condenser to check for dirt between the fins.
- Blow compressed air or rinse with water from the inside out (opposite direction of airflow).
- If dirt still remains, call a service agent to clean the condenser.

Warning

The condenser fins are sharp. Use care when cleaning them.

Removal from Service/Winterization

GENERAL

Special precautions must be taken if the ice machine is to be removed from service for an extended period of time or exposed to ambient temperatures of 32°F (0°C) or below.

Notice

If water is allowed to remain in the ice machine in freezing temperatures, severe damage to some components could result. Damage of this nature is not covered by the warranty.

AIR-COOLED MODELS

1. Turn off the ice machine by pressing the On/Off button.
2. Turn off the water supply.
3. Remove the water from the water trough.
4. Disconnect and drain the incoming ice-making water line at the rear of the ice machine.
5. Energize the ice machine and wait one minute for the water inlet valve to open - or - Energize all relays in the touchscreen service menu.
6. Blow compressed air in both the incoming water and the drain openings in the rear of the ice machine until no more water comes out of the water inlet lines or the drain.
7. Disconnect the electric power at the circuit breaker or the electric service switch.
8. Make sure water is not trapped in any of the water lines, drain lines, distribution tubes, etc.

WATER-COOLED MODELS ONLY

1. Perform steps 1-6 under “Air-Cooled Ice Machines”.
2. Disconnect the incoming water and drain line from the water-cooled condenser.
3. Start the ice making cycle by pressing the On/Off button and wait for the freeze cycle. The increasing refrigerant pressure will open the water regulating valve.
4. Blow compressed air through the condenser until no water remains.
5. Turn off ice machine by pressing the On/Off button and then disconnecting power to the ice machine.
6. Replace all panels.
7. Perform a lock out tag out procedure.

THIS PAGE INTENTIONALLY LEFT BLANK

Section 5 Troubleshooting

Before Calling for Service Checklist

If a problem arises during operation of your ice machine, follow the checklist below before calling service. Routine adjustments and maintenance procedures are not covered by the warranty.

Problem	Possible Cause	To Correct
Ice machine does not operate.	No electrical power to the ice machine.	Replace the fuse/reset the breaker/turn on the main switch/plug power cord into receptacle.
	Ice machine needs to be turned on.	Place the toggle switch in the ICE position to start ice making.
	Curtain in open position.	Curtain must be in the closed position and capable of swinging freely.
Ice machine stops, and can be restarted by turning the ice machine OFF and then ON.	Safety limit feature stopping the ice machine.	Refer to “Service Limit Feature” on page 47.
Ice sheet is thick	Water trough level is too high.	Adjust ice thickness float.
	Power button was turned off/on during freeze cycle and ice remained on evaporator.	Allow ice to thaw and release from evaporator, then restart.
	Ice damper was opened then closed in the harvest cycle before the ice released.	Allow ice to thaw and release from evaporator, then restart.
Ice machine does not release ice or is slow to harvest.	Ice machine is dirty.	Clean and sanitize the ice machine.
	Ice machine is not level.	Level the ice machine.
	Low air temperature around ice machine (air-cooled models).	Air temperature must be at least 40°F (4°C).
	Water regulating valve leaks in harvest mode (water-cooled models).	Replace water regulating valve.

Problem	Possible Cause	To Correct
Ice machine does not cycle into harvest mode.	The six-minute freeze time lock-in has not expired yet.	Wait for freeze lock-in to expire.
	Ice thickness float switch is dirty.	Clean and sanitize the ice machine.
	Ice thickness float switch wire is disconnected.	Connect the wire.
	Ice thickness float switch is out of adjustment.	Adjust the ice thickness float switch.
	Uneven ice fill (thin at top of evaporator).	See “Shallow or Incomplete Cubes”.
Ice quality is poor (soft or not clear).	Poor incoming water quality.	Contact a qualified service company to test the quality of the incoming water and make appropriate filter recommendations.
	Water filtration is poor.	Replace the filter.
	Ice machine is dirty.	Clean and sanitize the ice machine.
	Water softener is working improperly (if applicable).	Repair the water softener.
Ice machine produces shallow or incomplete cubes, or the ice fill pattern on the evaporator is incomplete.	Ice thickness float switch is out of adjustment.	Adjust the ice thickness float switch.
	Water trough level is too high or too low.	Check the water level and adjust if required.
	Water filtration is poor.	Replace the filter.
	Hot incoming water.	Connect the ice machine to a cold water supply.
	Incorrect incoming water pressure.	Water pressure must be 20-80 psi (137.9 - 551.5 kPa).
Ice machine is not level.	Level the ice machine.	

Problem	Possible Cause	To Correct
Low ice capacity.	The condenser is dirty.	Clean the condenser.
	High air temperature around ice machine (air-cooled models).	Air temperature must not exceed 110°F (43°C).
	Inadequate clearance around the ice machine.	Provide adequate clearance.
	Objects stacked around ice machine, blocking airflow to condenser (air-cooled models).	Remove items blocking airflow.
	Hot incoming water.	Connect the ice machine to a cold water supply.
	Incorrect incoming water pressure. Water pressure is too low or water filter is restricted.	Water pressure must be 20-80 psi (137.9 - 551.5 kPa). Refer to Section 2 for water requirements. Replace water filter.

Service Limit Feature

In addition to the standard safety controls, such as the high pressure cutout, your ice machine features built-in safety limits which will stop the ice machine if conditions arise which could cause a major component failure.

Refer to Service Limits Section 3 for more information.

Before calling for service, re-start the ice machine using the following procedure:

1. Move the toggle switch to OFF, then the ICE position,
 - A. If the service limit feature has stopped the ice machine, it will restart after a short delay. Proceed to step 2.
 - B. If the ice machine does not restart, see “Ice machine does not operate” on page 45.
2. Allow the ice machine to run to determine if the condition repeats.
 - A. If the ice machine stops again, the condition has repeated. Call for service.
 - B. If the ice machine continues to run, the condition has corrected itself. Allow the ice machine to continue running.

THIS PAGE INTENTIONALLY LEFT BLANK

KOOLAIRE[®]

KOOLAIRE – ICE MACHINE DIVISION
2110 SOUTH 26TH STREET, MANITOWOC, WI 54220

800-545-5720
WWW.KOOL-AIRE.COM