



PROJECT NAME: _____

LOCATION: _____

ITEM #: _____ QTY: _____

MODEL: _____

STEAM TABLES

FEATURES

- HEAVY DUTY STAINLESS STEEL BODY AND WELLS
- GALVANIZED STEEL LEGS & UNDERSHELF
- ACCOMODATES FULL SIZE FOOD PANS
- 8" POLYETHYLENE CUTTING BOARD PREP AREA
- INDEPENDENT CONTROL KNOBS WITH GUARDS
- 8" DEEP OPEN WELL
- 1 YEAR WARRANTY
- UL AND NSF CERTIFIED



28W-109

Hold food at the perfect temperature every time.



28W-110



28W-111 & 28W-112



28W-113

SPECIFICATIONS

ITEM	WIDTH	DEPTH	HEIGHT	VOLTAGE	PLUG TYPE	WELLS	WATTS PER WELL
28W-109	29"	30"	34"	120	NEMA 5-15P	2	500
28W-110	44"	30"	34"	120	NEMA 5-15P	3	500
28W-111	57"	30"	34"	120	NEMA 5-30P	4	500
28W-112	57"	30"	34"	240	NEMA 6-20P	4	750
28W-113	72"	30"	34"	240	NEMA 6-20P	5	750



PROJECT NAME: _____

LOCATION: _____

ITEM #: _____ QTY: _____

MODEL: _____

STEAM TABLES

3 WELL MODEL SHOWN FOR REFERENCE. ALL MODELS ARE THE SAME HEIGHT AND DEPTH. REFER TO SPEC TABLE FOR WIDTHS.

FRONT



HEIGHT
34"

SIDE

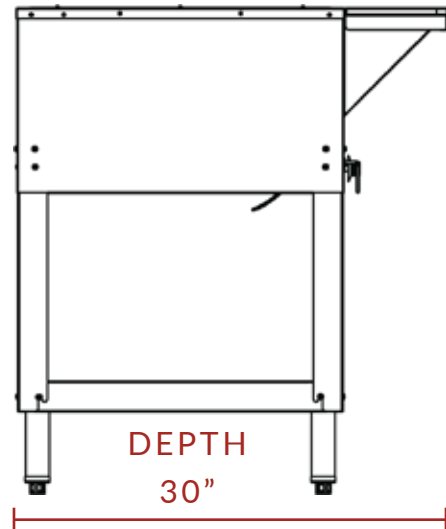

DEPTH
30"

TOP

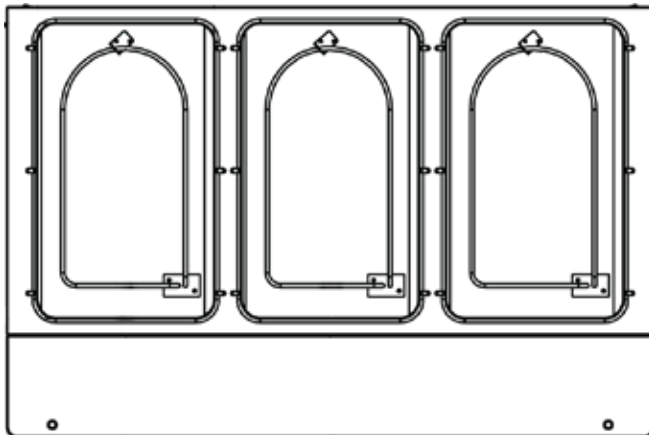

OPEN WELLS CAN BE USED DRY
OR WET WITH A SPILLAGE PAN
(SOLD SEPARATELY)

ACCESSORIES

ADD MOBILITY OR MORE STORAGE POTENTIAL

ITEM	DESCRIPTION
28W-114	5" SWIVEL CASTER WITH LOCK FOR KRATOS STEAM TABLES
28W-115	29" OVERSHELF WITH SNEEZE GUARD FOR 2 WELL KRATOS STEAM TABLE
28W-116	43" OVERSHELF WITH SNEEZE GUARD FOR 3 WELL KRATOS STEAM TABLE
28W-117	57" OVERSHELF WITH SNEEZE GUARD FOR 4 WELL KRATOS STEAM TABLE
28W-118	71" OVERSHELF WITH SNEEZE GUARD FOR 5 WELL KRATOS STEAM TABLE