



## CDR-115 Dough Prepper



### Ideal for:

- Pizza
- Flatbreads

### Highlights:

- One pass operation
- Prep pie on tray for tossing or go straight to oven
- Sheets dough up to 11" (28cm wide)

**Designed to perform large  
machine tasks in a small  
work space.**

## CDR-115

# Dough Prepper

## Boost Production with the Ultimate Pizza Prepper!

### Features

- Synthetic rollers eliminate dough build up
- Safety sensors for automatic shutoff
- Compact design, ideal for use in limited space
- Sanitary, heavy duty, all stainless steel welded construction
- Spring loaded scrapers readily removable for easy cleaning
- Simple handle adjustments for exact uniform dough thickness
- Ergonomic design for easy operation
- Drive mechanism isolated from roller area
- Safe, simple, easy to operate, easy to clean

### Industry Uses

- Pizzerias
- Restaurants
- Institutions
- Schools
- Ethnic food production
- Cafes
- Bakeries

### Contact us

978.667.3355 | 800.772.440

Fax: 978.671.9466

Email: [somerset@smrset.com](mailto:somerset@smrset.com)

[smrset.com](http://smrset.com)

Somerset Industries, Inc.  
137 Phoenix Ave  
Lowell, MA 01852 USA

### Hand Stretch or Toss



### Specifications

(Specifications subject to change without notice)

**Rollers:** 3.5" (8.89 cm) dia. 11" (28 cm) length

**Scrapers:** Synthetic, Spring Loaded, Removable

**Bearings:** Sealed Ball Bearings, Permanently Lubricated

**Gear Motor:** Heavy duty 1/4 HP, Maintenance Free, Single phase 115V/60Hz, 2.3 Amps or 220V/50Hz, 1.2 Amps

**Finishing:** All Stainless Steel

**Weight:** 75lbs (34Kgs)

**Shipping Weight:** 90 lbs (41kgs)

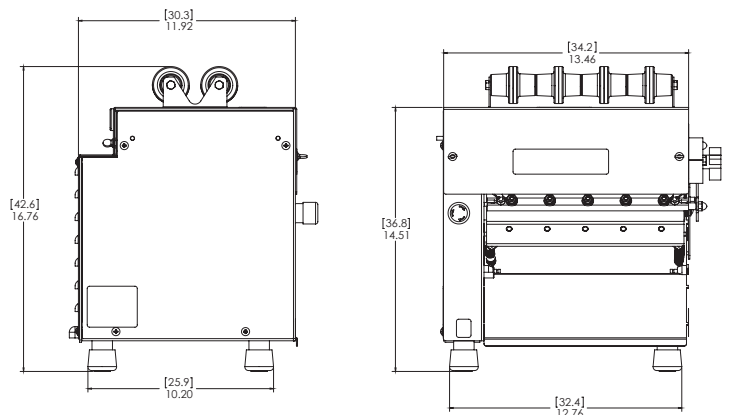

Scan the code to learn more about the CDR-115

