

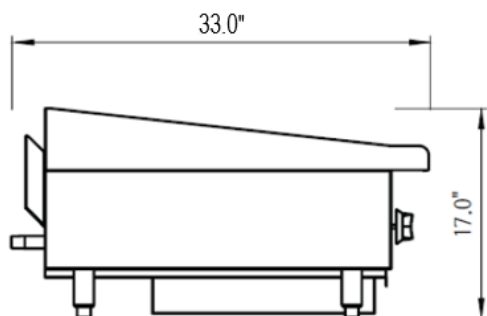

GRIDDLES

24" Deep Cook Surface, Manual Control
24", 36", 48" & 60" widths
CCMG31 Series

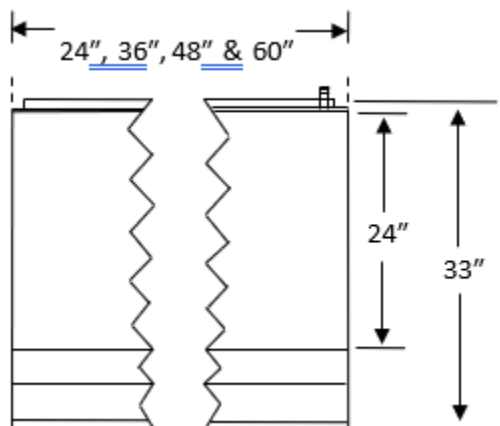

Model CCMG3148



See website for details

Standard Features, Benefits & Options

CONSTRUCTION: 24", 36", 48" & 60" wide models available. Easy cleaning, corrosion resistant stainless steel finish. Double wall construction. Bull-nose landing. 4" tall adjustable legs. High-capacity stainless steel grease drawer.

CONTROLS: Manual brass gas controls. Front accessible automatic standing pilots and pressure regulators.

BURNERS: 30,000 BTU stainless steel "U" shaped burners are combined with special heat directing baffles to provide even heating across the entire cooking surface. 1 burner per 12" increment.

GRIDDLE PLATE: High polish cold roll carbon alloy steel, 1" thick by 24" deep griddle plate. Double welded underneath and along the surface seam. 4" splash guard tapers to 1.5". 3.5" grease trough.

Model #	Width x Depth		Burners Total BTU	Ship Wgt.	
	in.	mm		lbs.	kg.
CCMG3124-1	24" x 33"	610 x 838	2 ----- 60,000	290	132
CCMG3136-1	36" x 33"	914 x 838	3 ----- 90,000	400	182
CCMG3148-1	48" x 33"	1219 x 838	4 ----- 120,000	520	260
CCMG3160-1	60" x 33"	1524 x 838	5 ----- 150,000	690	314

TESTING: Optimal pressure is 5" WC for natural gas, 10" WC for propane. ETL design & ETL Sanitation (ANSI-NSF4) certified.



Comstock-Castle Stove Co. • 119 W. Washington St. • Quincy, IL. 62301
Tel.: 217-223-5070 • Fax.: 217-223-0007 • Web: www.castlestove.com

