



**MODEL MARK V-200**  
Full-Size Bakery Depth  
Electric Convection Oven



*Shown with optional casters*

**OPTIONS AND ACCESSORIES**  
(AT ADDITIONAL CHARGE)

- **Control options:**
  - SSI-D - Solid state infinite control w/digital timer
  - SSI-M - Solid state infinite control w/manual timer
  - SimpleTouch - NEW touchscreen control with ability to store and group recipes. Includes rack timing, Cook&Hold, Fan Delay, Fan Pulse, easy download for recipe writing on your laptop, and HACCP storage capability
- **Legs/casters/stands:**
  - 6" (152mm) seismic legs
  - 6" (152mm) casters
  - 4-1/4" (108mm) low profile casters (double only)
  - 25" (635mm) stainless steel stand w/rack guides
  - 29" (737mm) stainless steel, fully welded, open stand with pan supports
- Stainless steel oven liner
- Extra oven racks
- Solid stainless steel back
- 480 volt, 3 phase
- Prison package (includes security control panel and stainless steel back)
- Vent connector

**OPTIONS AND ACCESSORIES**  
(AT NO CHARGE)

- Solid stainless steel doors

Project \_\_\_\_\_

Item No. \_\_\_\_\_

Quantity \_\_\_\_\_

Extra depth baking compartment- accepts five 18" x 26" standard full-size baking pans in left-to-right or front-to-back positions.

All data is shown per oven section, unless otherwise indicated.

*Refer to operator manual specification chart for listed model names.*

**EXTERIOR CONSTRUCTION**

- Full angle-iron frame
- Stainless steel front, top and sides
- Dual pane thermal glass windows encased in stainless steel door frames
- Powder coated door handle with simultaneous door operation
- Triple-mounted pressure lock door design with turnbuckle assembly
- Modular slide out front control panel for easy access
- Solid mineral fiber insulation at top, back, sides and bottom

**INTERIOR CONSTRUCTION**

- Double-sided porcelainized baking compartment liner (14 gauge) for easy cleaning
- Aluminized blower wheel
- Five chrome-plated racks, eleven rack positions with a minimum of 1-5/8" (41mm) spacing
- Interior lights

**OPERATION**

- Three tubular heaters
- Solid state thermostat with temperature control range of 200°F (93°C) to 500°F (260°C)
- Two speed fan motor
- 1/2 horsepower blower motor with automatic thermal overload protection
- Control area cooling fan
- Two halogen oven lamps

**STANDARD FEATURES**

- SSD - Solid state digital control with LED display, Cook & Hold and Pulse Plus®
- 25" (635mm) adjustable stainless steel legs (for single units)
- 6" (152mm) adjustable stainless steel legs (for double sections)
- Three year parts and two year labor warranty
- Five year limited oven door warranty\*

*\* For all international markets, contact your local distributor.*



**Intertek**

**BLODGETT OVEN COMPANY**

[www.blodgett.com](http://www.blodgett.com)

42 Allen Martin Drive, Essex Junction, VT 05452  
Phone: (802) 658-6600 • Fax: (802) 864-0183

**MARK V-200**



# MARK V-200

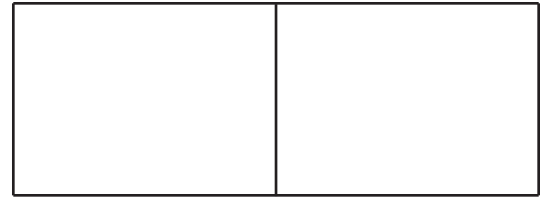

APPROVAL/STAMP

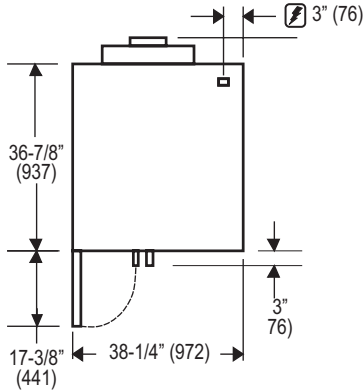

TOP VIEW

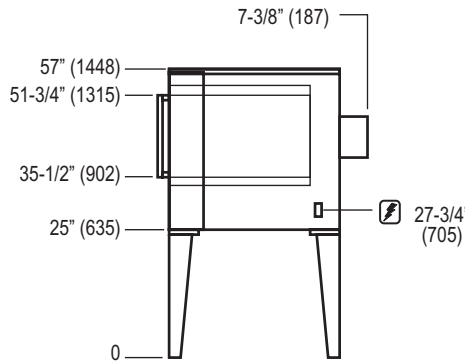

SINGLE

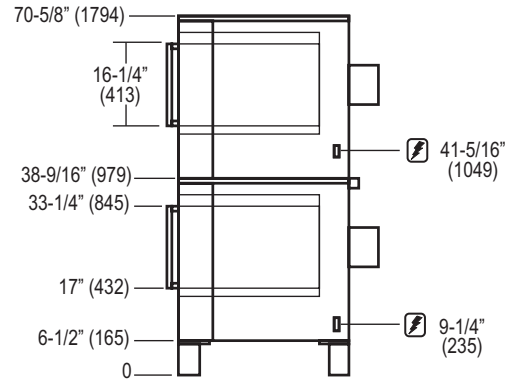

DOUBLE

Dimensions are in inches (mm)

**SHORT FORM SPECIFICATIONS** - Provide Blodgett full-size convection oven model MARK V-200, (single/double) compartment. Each compartment shall have (porcelainized/stainless) steel liner and shall accept five 18" x 26" standard full-size bake pans. Doors shall (be solid stainless steel/ have dual pane thermal glass windows) with single powder coated handle and simultaneous operation. Unit shall be electrically heated with three tubular heaters. Air in baking chamber distributed by single inlet blower wheel powered by a two-speed, 1/2 HP motor with thermal overload protection. Each chamber shall be fitted with two halogen lamps, five chrome-plated removable racks and removable crumb trays. Control panel shall be recessed with solid state digital control with LED display, Cook & Hold and Pulse Plus. Provide three year parts, two year labor and five year door warranty. Provide options and accessories as indicated.

**DIMENSIONS:**

- Floor space: 38-1/4" (972mm) W x 36-7/8" (936mm) L
- Product clearance: 1/2" from combustible and non-combustible construction.
- Interior: 29" (737mm) W x 20" (508mm) H x 28-1/4" (718mm) D

**If oven is on casters:**

- Single Add 4-1/2" (114mm) to all height dimensions
- Double Dimensions do not change
- Double Low Profile Subtract 2-1/2" (64mm) from all dimensions

**POWER SUPPLY:**

- 208 VAC 60 Hz. 1 phase 11KW 51/0/51 Amperes
- 208 VAC 60 Hz. 3 phase 11KW 31/29/29 Amperes
- 220/240 VAC 60 Hz. 1 phase 11KW 44/0/44 Amperes
- 220/240 VAC 60 Hz. 3 phase 11KW 26/24/24 Amperes
- 440 VAC 60 Hz. 3 phase 11KW 15/14/14 Amperes
- 480 VAC 60 Hz. 3 phase 11KW 14/13/13 Amperes
- 1/2 HP, 2 speed motor, 1120 & 1710 rpm (60 Hz)
- (50 Hz. ovens for 400/230, 380Y/220 VAC or 415Y/240 VAC (4 wire) 3 phase are available)

**MAXIMUM INPUT:**

- Single 11KW
- Double 22KW (11KW each section)

**MINIMUM ENTRY CLEARANCE:**

- Uncrated 32-1/16" (814mm)
- Crated 37-1/2" (953mm)

**SHIPPING INFORMATION:**

**Approx. Weight:**

- Single: 545 lbs. (247 kg)
- Double: 1060 lbs. (481 kg)

**Crate sizes:**

37-1/2" (952mm) x 43-1/2" (1105mm) x 51-3/4" (1315mm)

**NOTE:** The company reserves the right to make substitutions of components without prior notice

**BLODGETT OVEN COMPANY**

www.blodgett.com • 42 Allen Martin Drive, Essex Junction, VT 05452 • Phone: (802) 658-6600 • Fax: (802) 864-0183