



# Electrolux

## EMPower Smooth Gas Griddle Top - 12"

ITEM # \_\_\_\_\_

MODEL # \_\_\_\_\_

NAME # \_\_\_\_\_

SIS # \_\_\_\_\_

AIA # \_\_\_\_\_



Electrolux



EMPower  
Smooth Gas Griddle Top - 12"  
169111 (ARG12FL)

EMPower Restaurant Range griddle, 12" wide, gas, 26,000 BTU, smooth top, with 4" adjustable, removable legs

**Short Form Specification**

Item No. \_\_\_\_\_

EMPower unit to be Electrolux Smooth Gas Griddle Top with single high efficiency 26,000 BTU (7,6 kW) burner. Suitable for natural gas or propane gas. Thick 1" (25 mm) mild steel griddle plate maintains selected temperatures and assures quick recovery. 3,2" (81,5 mm) wide drainage channel running on full length of cooking surface. Large grease drainage hole diameter 2,4" (60mm). Single 1 pt. (0.5 l) grease collector drawer captures all excess grease and oil and can be easily extracted for easy dumping and cleaning. Worktop in AISI 304 Stainless Steel. 3mm stainless steel splashback. Front and side panels in Stainless Steel with Scotch Brite finish. Special heavy duty chrome plated knob for durability and easy cleaning. All major components can be accessed from front of the appliance for ease of maintenance. The configuration of bezel and knob provides high level of protection against water infiltrations. Right-angled side edges to allow flush fitting joints between EMPower units. Supplied with 4" (102mm) height adjustable, removable legs. EMPower unit may be installed on refrigerated base or open cupboard.

### Main Features

- Two high efficiency 26,000 BTU (7,6 kW) burners.
- Thick 1" (25 mm) mild steel griddle plate maintains selected temperatures and assures quick recovery.
- Suitable for natural gas or propane gas.
- Flame failure device to protect against accidental extinguishing of the flame.
- 3" (81,5 mm) wide drainage channel running on full length of cooking surface.
- Large grease drainage hole diameter 60mm.
- Single half gal. (2 l) grease collector drawers with hole to indicate when full, captures all excess grease and oil and can be extracted for easy dumping and cleaning.
- 3mm stainless steel splashback.
- Front and side panels in Stainless Steel with Scotch Brite finish.
- All major compartments located in front of unit for ease of maintenance.
- Special heavy duty chrome plated knobs for durability and easy cleaning.
- The configuration of bezels and knobs provides high level of protection against water infiltrations.
- Right-angled side edges to allow flush fitting joints between units, eliminating gaps and possible dirt traps.
- Provided with kit for side-by-side connection between units for minimizing gaps and possible dirt traps.
- Supplied with 4" (102mm) height adjustable, removable legs.
- Unit may be installed on refrigerated base by removing the legs and inserting the special pins (optional accessory).
- Unit may be installed on open cupboard by removing the legs and inserting the screws provided as standard with the open cupboards.
- Included Accessories: propane converter kit, pressure regulator and main shut off valve.
- In compliance with ETL Certification (UL & NSF).
- Configured for Natural Gas, LP Conversion Kit Included.

### Construction

- Worktop in 304 AISI stainless steel.
- 4 screws to install on the cupboard base are supplied with the unit.
- Gas pressure regulator is supplied with the unit.

### Optional Accessories

- Scraper for smooth griddle  PNC 164255
- EMPower - 4 pins to fix top to refrigerated/open base  PNC 169048
- EMPower back mounted rear shelf-spacer, 12" unit  PNC 169096
- Portioning Shelf 12"  PNC 169173



APPROVAL: \_\_\_\_\_

EMPower  
Smooth Gas Griddle Top - 12"

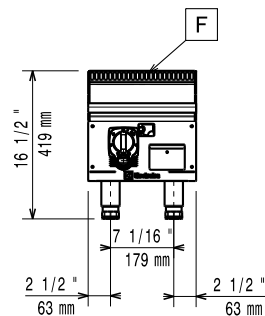
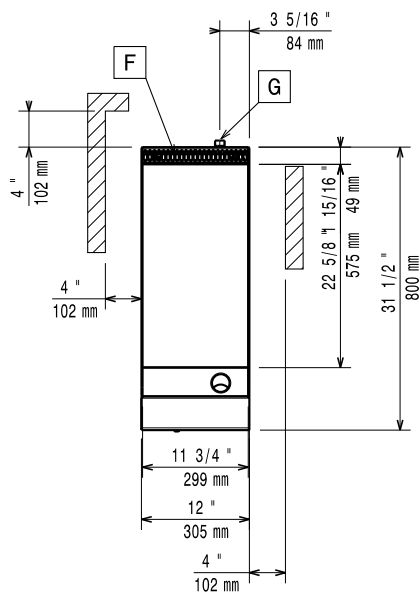
**Front**

**Top**

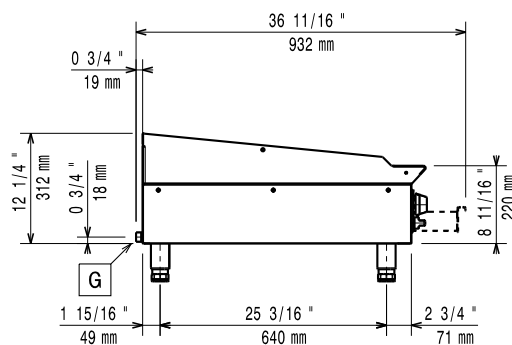
**EQ** = Equipotential screw  
**G** = Gas connection

**Side**

**Gas**
**Gas Power:**

169111 (ARG12FL) 26000 Btu/hr (7.6 kW)

**Gas Inlet:**

3/4"

**Key Information:**

**External dimensions, Width:** 12 1/64" (305 mm)

**External dimensions, Depth:** 31 1/2" (800 mm)

**External dimensions, Height:** 16 1/2" (419 mm)

**Net weight:** 82 lbs (37 kg)

**Shipping width:** 35 7/16" (900 mm)

**Shipping depth:** 14" (355 mm)

**Shipping height:** 25 1/2" (648 mm)

**Shipping weight:** 93 lbs (42 kg)

**Shipping volume:** 7.31 ft<sup>3</sup> (0.21 m<sup>3</sup>)

\* The rear and side clearances shown on the diagram indicate the minimum distances recommended from the appliance to combustible surfaces.