

**SPECIFICATIONS**

**Short Form Specs**

Winston CVap Hold/Serve Drawer, model HBB5D1 with electronic differential controls to provide food temperature control from 90 to 180°F (32 to 82°C) and maintain food texture with settings from 90 to 180°F (32 to 82°C). 250°F (121°C) maximum drawer temperature. Utilizes Controlled Vapor Technology (patent #5,494,690) as a method and apparatus for holding hot foods, consisting of an air heater and water heater to establish ideal water vapor content that is in relation with the moistness characteristics for the food.

**Construction**

<b>Control</b>	Electronic differential control allows precise control of food temperature and food texture.
<b>Capacity</b>	1 Steam Table Pan (12" x 20" x 2.5") 2 Half Steam Table Pan (12" x 10" x 2.5") 3 Third Steam Table Pan (12" x 6.3" x 2.5") 1 Gastronorm Pan 1/1
<b>Load Limit</b>	20 lbs. (9.07 kg) per drawer.
<b>Electrical</b>	Supplied with 84" (2,134 mm) (minimum) power cord and plug.
<b>Drawers</b>	Accepts one full steam table pan (up to 6" (152 mm) deep), two half steam table pans, three third steam table pans, or one 1/1 gastronorm pans. Easy to remove and replace.
<b>Materials</b>	To be commercial and institutional grade stainless steel interior to provide ease of cleaning and long service life with reasonable use and care.
<b>Evaporator</b>	Holds approximately 0.8 (3 L) gallons of water.
<b>Water Fill</b>	Operated manually. Low mineral potable water is recommended, otherwise use deionizer/demineralizer to minimize corrosive damage.
<b>Installation Requirements</b>	Units to be installed with 2" (51mm) clearance on sides and may not be installed within proximity to anything omitting heat that would allow the exterior of the Winston cabinet to exceed surface temperatures of >200°F. Refer to owner's manual for specific installation requirements. Generally, this equipment is not required to be installed under Type 1 or Type 2 Hoods; however, check local health and fire codes for requirements specific to the location.



**HBB5D1**  
CVAP HOLD/SERVE DRAWER  
*Electronic Differential Controls*



**New Handle Design**  
Comfortable grip with a sleek modern look.



**Easy Fill Spout**  
Makes filling and draining the unit a snap!



*CVap® Hold/Serve Drawers are designed for high quality holding and serving of a wide variety of menu items for extended times. They are ideal for holding, warming, and serving.*

JOB

ITEM#

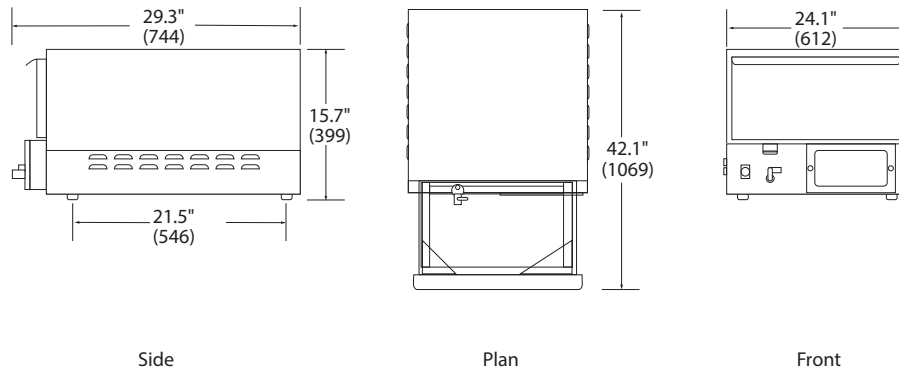

capacity	size in (mm)	volts	hertz	ph	amps	watts	nema	ship wt. lb (kg)	ship cube		
US / CANADA											
1 STP	H= 15.7" (399)	120	60	1	13.1	1572	US 5-15P	110 (50)	8.7 (0.25)		
2 Half STP	H4= 19.7" (500)						CAN 5-20P				
3 Third STP	H6= 21.7" (551)										
1 GP 1/1	W= 24.1" (612) D= 29.3" (744)	INTERNATIONAL									
Accepts up to 6" deep pans		230*	50/60	1	6.8	1572	N/A	110 (50)	call factory		

STP= Steam Table Pan (12" x 20" x 2.5") (up to 6") • H4= Height w/4" legs • H6= Height w/6" legs • GP= Gastronorm Pan

**CONTROLLED VAPOR TECHNOLOGY** (U.S. patent # 5,494,690) establishes that the water vapor content in the drawer is the same as that of the food. This unique process controls moisture evaporation and saturation, so crisp foods stay crisp, and moist foods stay moist.

**EASY-TO-USE CONTROLS** understand and reliable. These controls never need field calibration. **FOOD TEMP KEYS** allow control of food temperature from 90 to 180°F (32 to 82°C). **FOOD TEXTURE KEYS** maintain just-cooked texture. Set near **FOOD TEMP** for moist foods, or set higher for crisp foods. 250° F (121° C) maximum drawer temperature.

**BUILT TO LAST WITH QUALITY CRAFTSMANSHIP** Built to last with quality craftsmanship, high grade stainless steel construction and full perimeter insulation.

**ALLOWS FOR BETTER CONTROL OF FOOD QUALITY** Features radial fan for improved food quality with frequent drawer openings, full perimeter drawer gaskets, and digital readout for water temperature.

**INDUSTRY COMPLIANT**, CVap equipment complies with domestic and international requirements such as UL, C-UL, UL Sanitation, CE, and others.

**WARRANTY.** Limited one year warranty. Warranty disclaimer for failure to clean. Ask for complete warranty disclosure.

**SPECIFY THE FOLLOWING WHEN ORDERING:**

Standard (No additional cost):

1. Feet: 1/2" (13 mm)
- \*Inquire about additional international voltages available.

Optional (Additional cost):

1. Legs: 4" (102 mm) legs or 6" (152 mm) legs.
2. Extended Warranty: Adds parts and labor warranty coverage for one additional year.
3. Added accessories or supplies.

Accessories & Supplies (Additional cost):  
PS2212 Perforated tray

**BUY WINSTON SERVICE PARTS, ACCESSORIES, AND SUPPLIES ONLINE!**  
Factory direct at [winstonind.com/buyparts](http://winstonind.com/buyparts)