

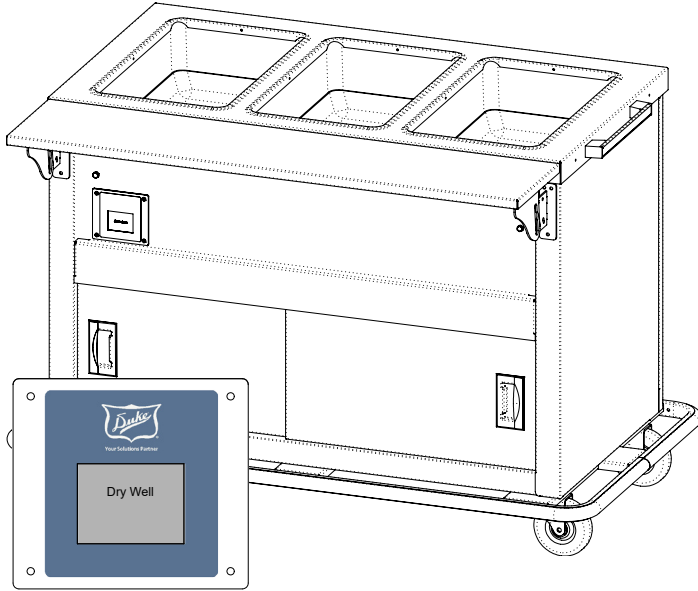

Your Solutions Partner

Specifications

F.O.B. Sedalia, Missouri 65301



Model EPW-3-CB

OPTIONS:

- 14 gauge tops
- Adaptor plates
- Veneered panels
- Powder coat paint colors
- Foodshields
- Trayslides

AGENCY LISTINGS:



DUKE MANUFACTURING CO.

2305 N. Broadway

St. Louis, MO 63102

800.735.3853 Toll Free

314.231.5074 Fax

www.dukemfg.com

Specification subject to change



Approval Stamp(s):

PRODUCT INFORMATION:

PROJECT: _____

ITEM: _____

QUANTITY: _____

MODEL:

Thurmaduke® Ganged Waterless Well Hot Food Units - Portable Cart

- EPW-3-CBPG/EPW-3-CBSS 3 top openings
- EPW-4-CBPG/EPW-4-CBSS 4 top openings
- EPW-5-CBPG/EPW-5-CBSS 5 top openings
- EPW-6-CBPG/EPW-6-CBSS 6 top openings

TOP:

- 16 gauge, 300 Series stainless steel
- Top openings die - stamped. 11-7/8" x 19-7/8"
- Stainless steel carving surface - drop brackets

Heat Compartments:

- 6-1/4" deep stainless steel liner for dry operation only
- Includes Silicone bottom pad
- Fully Insulated
- Rope element in each compartment

CONTROLS:

- Standard intuitive, easy to use touch screen control - One control for all wells
- Easily adjusted presets LOW/MED/HIGH
- Built in WIFI and Bluetooth for future connectivity.

BODY AND INTERIOR SHELF:

- 300 Series stainless steel or paint grip steel
- Stainless or paint grip steel sliding doors
- 5" diameter casters, two with locks
- 2-1/2" wide heavy-duty polyvinyl bumper around base of unit
- 14 gauge stainless steel channel frame for bumper

THURMADUKE® Ganged Waterless Well - Portable

Catalog No. Waterless Well

A.I.A. File No. 35-C-13



Ganged Waterless Well Portable

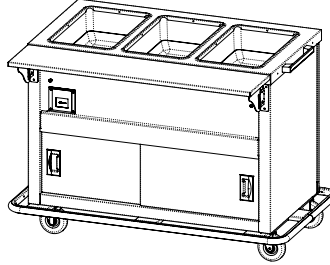
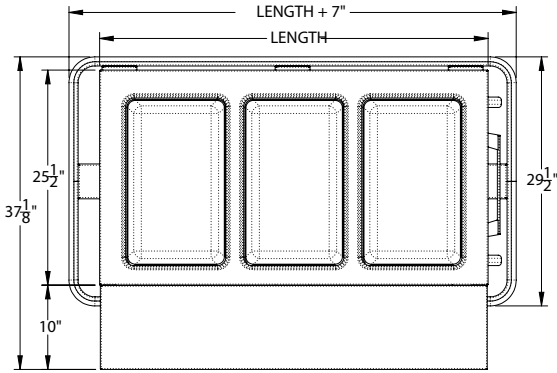

Control Specifications

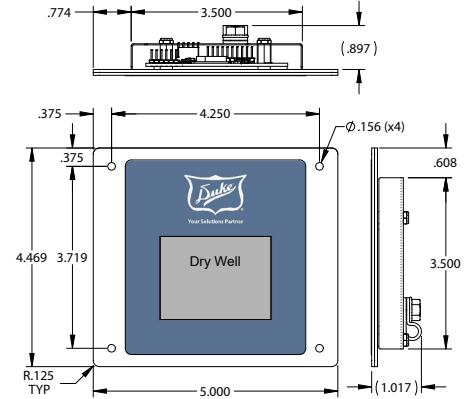

Control Cutout

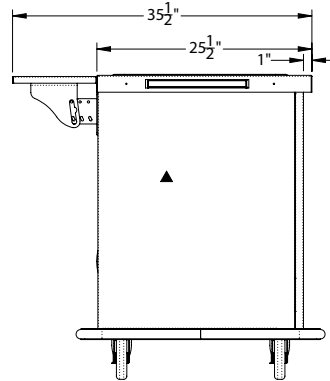
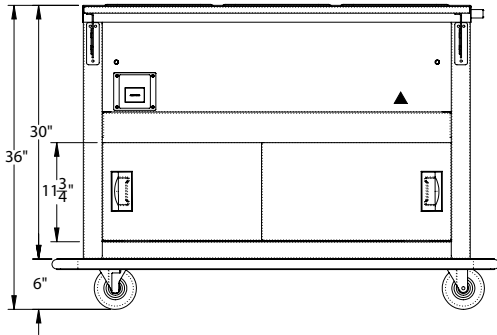
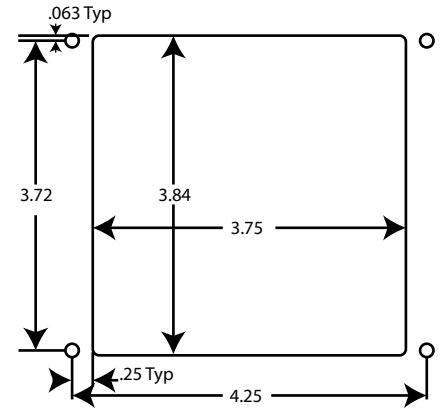

LEGEND	
▲	ELECTRICAL CONNECTION

DIMENSIONS:

FREIGHT CLASS: 150

Model		Length		Width		Height		Top Openings	Cube ft. Crated	Weight	
Enameled	Stainless	in	cm	in	cm	in	cm			lbs	kg
EPW-3-CBPG	EPW-3-CBSS	46	116.8	35-1/2	90.2	36	91.4	3	39.6	345	156.8
EPW-4-CBPG	EPW-4-CBSS	60	152.4	35-1/2	90.2	36	91.4	4	51.2	420	190.9
EPW-5-CBPG	EPW-5-CBSS	74	188.0	35-1/2	90.2	36	91.4	5	62.3	505	229.6
EPW-6-CBPG	EPW-6-CBSS	88	223.5	35-1/2	90.2	36	91.4	6	74.3	605	275.0

ELECTRICAL SPECIFICATIONS:

Model	120 Volt - 665 watt			208 Volt - 500 watt			240 Volt - 665 watt		
	Watts	Amps	NEMA	Watts	Amps	NEMA	Watts	Amps	NEMA
EPW-3-CBPG/SS	1995	16.6	L5-30	1500	7.2	6-20	1995	8.3	6-20
EPW-4-CBPG/SS	2660	22.2	L5-30	2000	9.6	6-20	2660	11.1	6-20
EPW-5-CBPG/SS	N/A	N/A	N/A	2500	12.1	6-20	3325	13.9	6-20
EPW-6-CBPG/SS	N/A	N/A	N/A	3000	14.4	6-20	3990	16.6	6-20



Duke Manufacturing Co.
 2305 N. Broadway
 St. Louis, MO 63102

Phone: 314-231-1130
 Toll Free: 1-800-735-3853
 Fax: 314-231-5074

www.dukemfg.com