



Item: _____

Quantity: _____

Project: _____

Royal Series

Models: RIBT-24 RIBT-36 RIBT-48 RIBT-60 RIBT-72



RIBT-36

Gas Type: Natural LP

Elevation (if above 2000 ft.): _____

Standard Features

- Full width, removable stainless steel crumb pan for easy cleaning
- Stainless steel front landing edge
- Stainless steel sides, front valve cover and ledge
- Double wall side panels for cooler sides
- Easily removable, heavy gauge welded stainless steel radiants protects burners from spills
- Heavy duty cast iron top grates
- Infrared burners rated at 35,000 BTU/hr each, every 12"
- Equipped with a 150°-500° F thermostat to maintain cooking temperature when hood is in closed position
- Individual burner control with manual valves
- Standing pilots for instant safe ignition
- Easily removable independent firebox assembly
- 24", 36", and 48" sizes are supplied with one stainless steel top hood
- 60" and 72" sizes are supplied with two stainless steel top hoods
- Stainless steel tubing for burners and pilots
- 4" high adjustable, heavy duty legs included

Options and Accessories

- Fish grate
- Diamond grate
- Stainless steel fire box
- Stainless Steel Equipment Stand
 - Knock Down All Welded
- Size
 - 24" 36" 48" 60" 72"
 - 5" swivel casters (set of four - 2 locking)
 - 5" swivel casters (set of six - 3 locking) (60" and 72" models)

Thermostatically Controlled Infrared Radiant Broiler



2 YEAR LIMITED, PARTS AND LABOR WARRANTY

Thermostatically Controlled Infrared Radiant Broiler

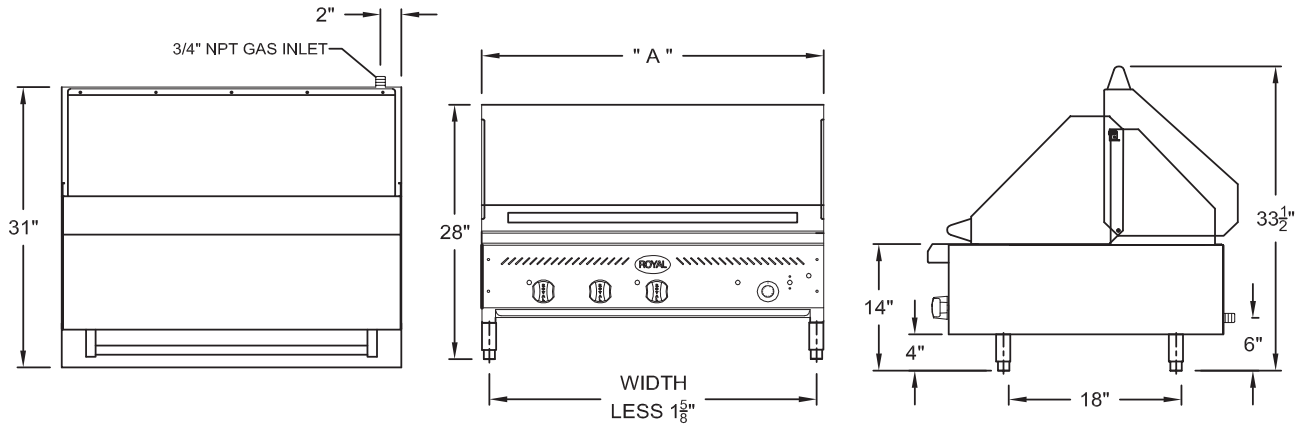

Model Number	Width (A)	Number of Burners	Total BTU	Ship Weight
RIBT-24	24"	2	70,000	240 lbs.
RIBT-36	36"	3	105,000	325 lbs.
RIBT-48	48"	4	140,000	420 lbs.
RIBT-60	60"	5	175,000	525 lbs.
RIBT-72	72"	6	210,000	640 lbs.

This equipment is developed with Gas Technology Institute and PG&E Food Service Technology Center and funded by the California Energy Commission's public energy research program.

TEST DATA OF FSTC	ROYAL RIBT	OTHER BROILERS
Heavy Load Efficiency	53%	30.50%
Heavy Load Cook Time	6 min	7 min
Cooking Energy Rate	57.5 kBTU/hr	74.6 kBTU/hr
Production Capacity	69.5 lbs/hr	56 lbs/hr
Preheat Time	12 min	16 min
Preheat Energy	19 kBTU	30 kBTU

Notes:

- Each burner is rated at 30,000 BTU/hr

Gas Connection:

3/4" NPT on the right hand rear of the appliance.

The pressure regulator (supplied) is to be connected by the installer.

Specify type of gas and altitude, if over 2,000 feet, when ordering.

Gas Pressure:

5" W.C.	Natural Gas
10" W.C.	Propane

Clearances:

	Combustible	Non-Combustible
Rear	4"	0"
Sides	15"	0"

Due to continuing product development to ensure best possible performance, these specifications are subject to change without prior notification.

Royal Range of California, Inc.
 3245 Corridor Dr. • Eastvale, CA 91752 • (800) 769-2414 • (951) 360-1600
 Fax: (951) 360-7500 • www.royalranges.com • sales@royalranges.com