

# SANDWICH UNIT REFRIGERATOR

## Model: SW60N24M-HGL

Natural Refrigerant R-290 Model

60" Mighty Top Sandwich Unit Refrigerator with Solid Doors and Hinged Glass Lid - 24 Pans

Stainless steel front, top and end panels, aluminum back and interior.



## Options and Accessories

(upcharge and lead times may apply)

Stainless steel interior	Adjustable legs
Stainless steel back	Optional caster sizes
Additional epoxy coated steel shelves	Rear mounted cutting board
Stainless steel shelves	Composite cutting board
Door locks	Crumb catcher
Drawers in lieu of doors (consult factory)**	

Consult factory for other model configurations, options and accessories.

\*\*Two Tier: (1) 12 x 20 x 6 pan per drawer

Project Name:

Model Specified:

Location:

Item No:

Quantity:

AIA #:

SIS #:

## Standard Model Features

### REFRIGERATION SYSTEM

Performance rated refrigeration system

Natural, environmentally safe, high efficiency R-290 refrigerant<sup>1</sup>

Unique air flow distribution allows pan product to maintain 33° - 41°F

Automatic, hot gas condensate evaporator

Non-corrosive, plasticized fin evaporator coil

Expansion valve system

Easily serviceable, back mounted compressor

### CABINET ARCHITECTURE

2" non-CFC polyurethane foam insulation

Smooth, polished chrome door handles

Spring loaded, self closing doors

Magnetic snap in Santoprene™ door gaskets

Heavy duty, epoxy coated steel shelves

8" deep, full length nylon cutting board

Energy efficient, 2 pane, low emissivity glass lid

Aluminum glass frame with satin finish

Concealed lid hinges

Integral stainless steel gas spring lid supports

Completely enclosed, vented and removable case back

5" casters

### MODEL FEATURES

(24) 1/2 size recessed pans, 4" deep

Removable interior tub below pans

Off-cycle defrost

Electronic controller w/ digital display & hi-low alarm

Field rehingeable doors

<sup>1</sup> R-290 refrigerant meets all federal and state regulatory requirements.

**Continental**  
Refrigerator

Toll-Free: 800-523-7138  
Phone: 215-244-1400  
Fax: 215-244-9579

539 Dunksferry Road  
Bensalem, PA 19020  
www.continentalrefrigerator.com

APPROVAL:

# Model Specifications

## DIMENSIONAL DATA

Net Capacity (cubic feet)	17.0 (481 cu l)
1/6 Size Pans (4" deep)	24
Width, Overall (inches)	60 (1524 mm)
Depth, Overall (inches) (including top, cutting board & bumpers)	35 (889 mm)
Depth, Cutting Board (inches)	8 (203 mm)
Height, Overall (inches) (including 5" casters)	36 13/16 (935 mm)
Shelf Area (square feet)	8.1 (0.8 sq m)
Number of Shelves	2
Number of Doors	2
Interior Depth (inches)	See Drawing
Interior Height (inches)	26 1/4 (667 mm)
Interior Width (inches)	56 (1422 mm)

## REFRIGERANT DATA

Condensing Unit Size (H.P.)	1/3+
Capacity (BTU per hour)*	2560

## ELECTRICAL DATA

Voltage (International)	115/60/1 (220/50/1)
Total Amps (International)	5.7 (3.6)
10 ft. Cord/Plug [attached] (International)	Yes (No)

## SHIPPING DATA

Weight (pounds)	368 (167 kg)
Height - Crated (inches)	43 1/4 (1099 mm)
Width - Crated (inches)	68 (1727 mm)
Depth - Crated (inches)	37 1/4 (946 mm)

\* Rating @ +25°F evaporator, 90°F ambient  
 Figures in parentheses reflect metric equivalents rounded to the nearest whole unit.



Equipped with one NEMA-5-15P Plug  
 (varies by country)

**Continental**  
 Refrigerator

Toll-Free: 800-523-7138  
 Phone: 215-244-1400  
 Fax: 215-244-9579

539 Dunksferry Road  
 Bensalem, PA 19020  
[www.continentalrefrigerator.com](http://www.continentalrefrigerator.com)

Due to our continued efforts in developing innovative products, specifications subject to change without notice.



© Copyright 2021. Continental Refrigerator.  
 A Division of National Refrigeration & Air Conditioning Products, Inc.

# Model Plan Views

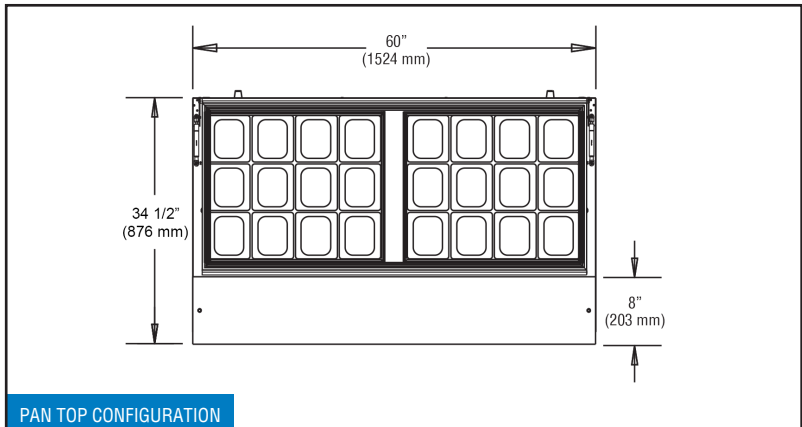
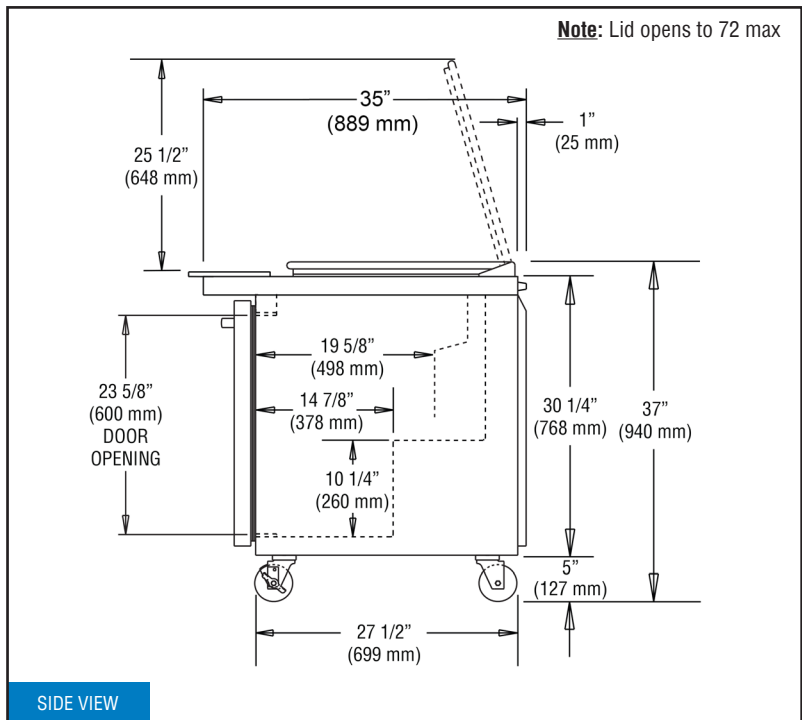
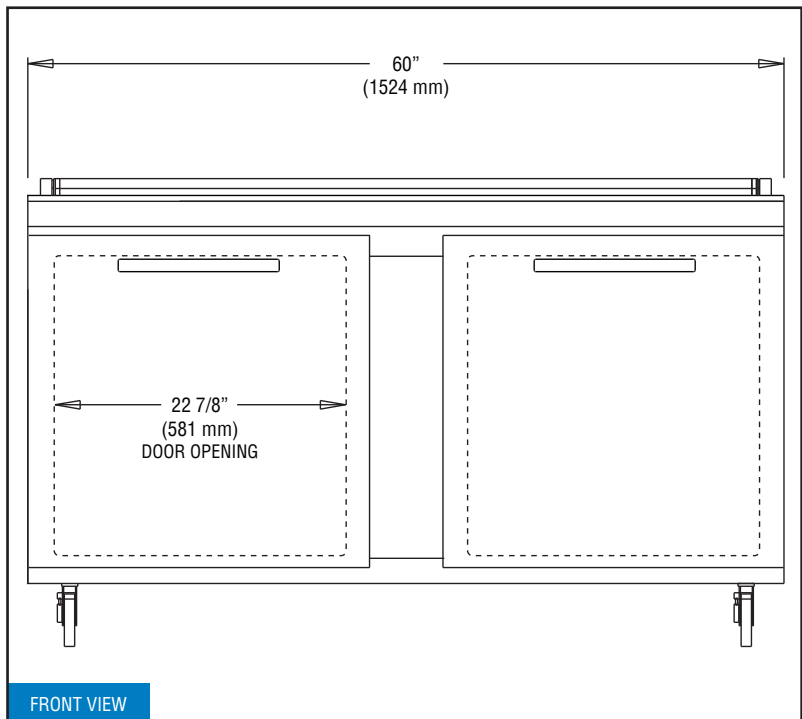

REVISED: 9/8/2022