



PFC

SEMI-AUTOMATIC VENTLESS
ELECTRIC COUNTERTOP DEEP FRYER

KEY FEATURES

- Integral ventless design
- Built-in fire suppression
- Hepa style air filtration
- Large output
- Small footprint
- Odorless
- Easy to clean

TOUCH CONTROL

- Cook time sensitivity (CTS)[™]
- Preset counters
- Food type sensitivity (FTS)[™]
- Stand by mode
- Hold time monitor



OPEN 
KITCHEN
Available

The Benchmark in Ventless Deep Frying

PERFECT FRY COMPANY

42 Allen Martin Drive, Essex Junction, VT 05452 (802) 658-6600 www.perfectfry.com

P/N 84271 Rev D (12/23)

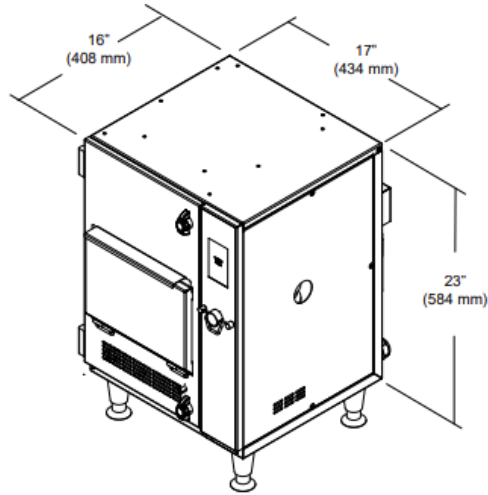

OPTIONS & ACCESSORIES

- **PERFECT FILTER KIT** - Includes: (1) Oil Filter unit, (1) hand held oil tester w/ wall mount, & (100) disposable filter pads
- **LOCKING DOOR LATCHES** Employee safe guard (must specify on order)
- **AIR FILTER REPLACEMENT KIT** Includes: (1) replacement air filter
- **EXTERNAL FIRE ALARM KIT**
- **EXTRA LARGE BASKET** 5" H x 10" W x 7" D
- **BASKET COVER/SUBMERGER SCREEN**
- **WIFI/CLOUD CONNECTIVITY** Optional wifi module to connect to **Open Kitchen**, allowing remote access and data acquisition.

COOKING CAPACITY

Oil Capacity	2 US Gallons (8 L)
Product Capacity	3 lb per load (1.3 kg)

WEIGHTS & SHIPPING

Product Weight	106 lbs (48.08 kg)
Shipping Weight	130 lbs (58.96 kg)
Shipping Dimensions	Depth 17.95" (456 mm) Width 17.94" (556 mm) Height 27.07" (688 mm)
Shipping Cube	7.56 ft ³ (.214 m ³)

CLEARANCES

Sides	1" (25.4mm)
Back	2" (50.8mm)
Top	0" (0mm)

ELECTRICAL SPECIFICATIONS

MODEL	VAC	KW	CYCLE	PHASE	AMP
PFC500	208	5.0	60	1	24
				3	14
PFA730	208	7.3	60	1	35
				3	21
PFC500	240	5.5	50/60	1	23
				3	14
PFA730	240	8.0	50/60	1	34
				3	20
PFC500	200	4.7	50/60	1	24
PFA730		6.8		1	34
PFC500	220	4.6	50/60	1	21
PFA730		6.7		1	31
PFC500	230	5.0	50/60	1	22
PFA730		7.3		1	32
PFC500	220/380	4.6	50/60	3	7
PFA730		6.7		3	11
PFC500	230/400	5.0	50/60	3	8
PFA730		7.3		3	11
PFC500	240/415	5.5	50/60	3	8
PFA730		8.0		3	12

For use on an individual branch circuit. Fryer must be properly connected to a grounded, dedicated phase circuit according to local standards and codes.

BASKET OPTIONS

Optional Basket Cover

Extra Large Basket
5" H x 10" W x 7" D

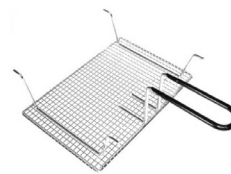

PERFECT FRY™
PORTABLE OIL FILTER

