



ULR60B-D4

Undercounter 60" Refrigerator with Drawers



ULR60B-D4
09/09/24
Item # 13690

W x D x H

60" x 33.25" x 33.875"*
*with 4" casters



Item #: _____

Project: _____

Qty: _____

AIA#: _____

Features

- ▶ Engineered to maintain NSF-7 temperatures in 100°F ambient.
- ▶ Stainless steel exterior front, sides, and top with stainless steel interior sides, back, and floor
- ▶ Front breathing air flow design
 - Environmentally friendly R290 hydrocarbon refrigerant
 - Cabinet and drawers are insulated with 2" CFC free, foamed in place polyurethane
 - Drawer slides are constructed of 14 gauge stainless steel with acetal rollers
 - Drawer frames are formed of 14 gauge stainless steel and securely fastened in the cabinet
 - Drawers will accommodate (2) 12 x 10" half size pans and (2) 12 x 6.5" 1/3 size pans, 6" deep pans (pans by others)
 - Drawer slides have a dynamic load capacity of 250 lbs.
 - Extruded aluminum flush mount drawer handle
 - Magnetic drawer gasket is easily removable for cleaning
 - Removable air filter for easy cleaning
 - Hot gas condensate removal
 - Mullion heaters for reduced condensation
 - Digital temperature display
 - E-coated evaporator coil
 - Standard with 4" casters (two with brakes)
 - 10 ft. cord and plug



Dimensions / Capacity

	Two-Section ULR60B-D4
Interior Storage Capacity (CF) (AHAM)	17.22 ft ³
Overall Width x Depth (including 1" bumper)	60" x 33.25"
Height (including 4" casters)	33.875"
Drawer Opening Width x Depth (including 1" bumper)	19.5" x 9"
Depth with Drawer Fully Open (including 1" bumper)	57.5"
Crated Weight	408 lbs.
Crated Length x Width x Height	63.75" x 35.75" x 36"

Electrical / Refrigeration

	Two-Section ULR60B-D4
Voltage	115/60/1
HACR Breaker	15.0 Amps
Electrical Connection (NEMA)	5-15P ⚡
Voltage Range	104-126
Ambient Temp. Range	45° to 100°F
Control Setpoint Range	28° to 45°F
Recommended Setpoint	36°F
Amperage	3
Energy Consumption (kWh/day) @NSF	1.26
Heat Rejection (BTU/Hr.) @NSF	305
Approx. Nominal Compres. BTU/HR (HP)	1354 (1/5HP)
Refrigerant / Charge Amount (oz)	R290 (2.2 oz)

Options

- 2" Casters (HS-5037, set of 4)
- 6" Casters (HS-5036, set of 4)
- Overshelves (HS-5639, single)
- Overshelves (HS-5640, double)
- Drawer divider bar (HS-4007, Vertical)
- Drawer divider bar (HS-5692, Horizontal)
- Stainless steel back panel (factory request)
- Drawer locks (factory request)



Valid in United States, Canada, Puerto Rico and U.S. Territories. Contact factory for warranty in other countries.

If GFCI is required, a GFCI breaker MUST be used in lieu of GFCI receptacle

Hoshizaki reserves the right to change specifications without notice.



ULR60B-D4

Undercounter 60" Refrigerator with Drawers



ULR60B-D4
09/09/24
Item # 13690

FRONT VIEW

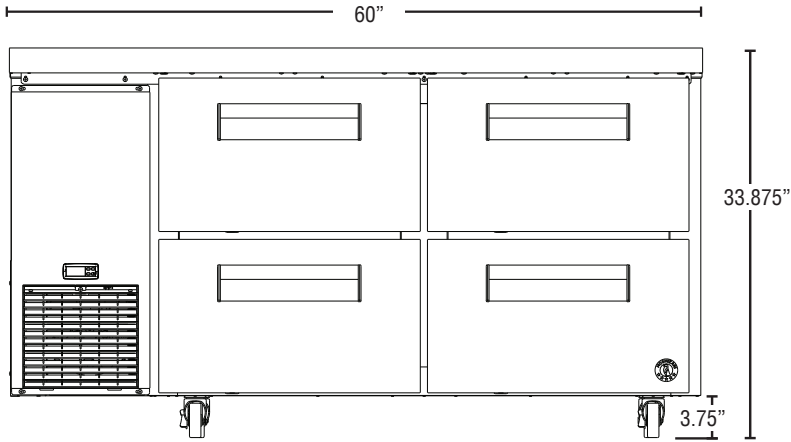

SIDE VIEW

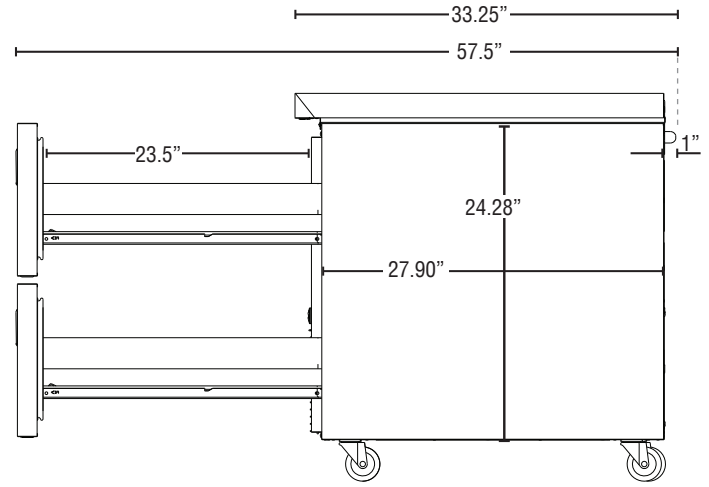

PLAN VIEW

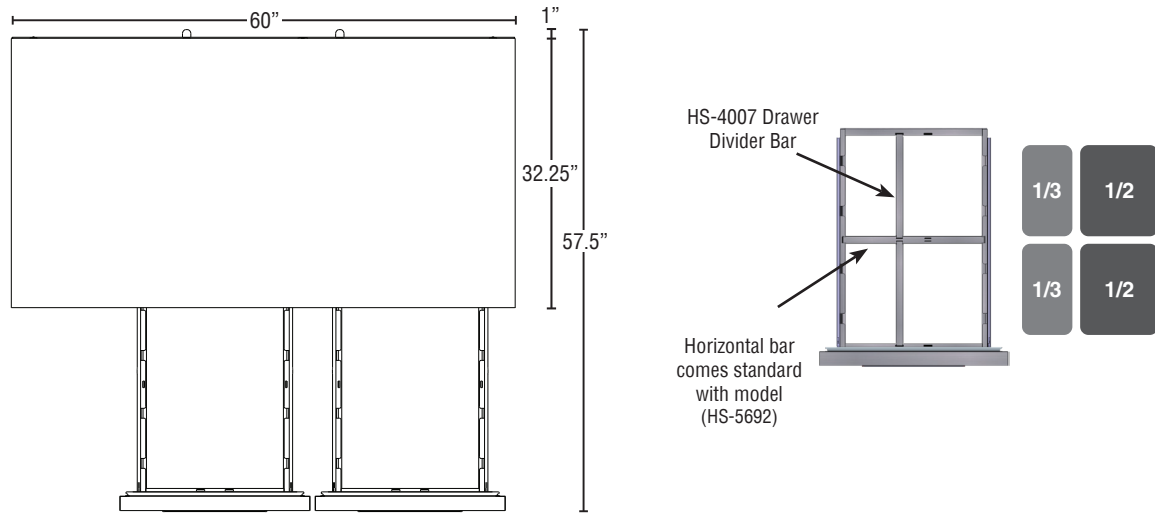

Cabinet Construction

The exterior cabinet top, front, and sides, are constructed of high quality stainless steel. The exterior back and bottom are constructed of coated steel. The cabinet interior features stainless steel back, sides, and floor with a stainless steel top. Mounted on anodized aluminum pilasters the shelves are adjustable in 1/2" increments. Cabinet walls are insulated with 2" CFC free, foamed in place polyurethane. 4" polyolefin, stem casters (two with brakes) are standard.

Drawer Construction

Drawer fronts are constructed of high grade stainless steel inside and out and are insulated with 2" CFC free foamed in place polyurethane. Each drawer accommodates (2) 12" X 10" X 6" and (2) 12" x 6" x 6" deep pans (pans by others). Drawer module frames are formed of 14 gauge stainless steel all welded construction and securely fastened in the cabinet. The drawer slides are constructed of 14 gauge stainless steel with delrin nylon rollers to prevent metal to metal contact between the drawer slides and help reduce wear. The drawer slides have a dynamic load capacity of 200 pounds. Drawers are provided with a one-piece extruded aluminum flush mount handle. Snap-in magnetic drawer gaskets are durable and easily removed for cleaning.

Refrigeration System

The high efficiency refrigeration system is self-contained with an E-coated evaporator for extended life. Condensate removal is accomplished with an energy efficient non-electric evaporation system. A capillary tube controls the flow of environmentally friendly R290 refrigerant through the evaporator. Refrigeration system utilizes an off-cycle defrost to eliminate any ice on the evaporator coil. 115 volt units are equipped with a ten foot cord and plug (20.0 amps or less).