

Heated GRAB'N GO Case MODEL GNG-2P2T



Capacity
Accommodates 2 x Full-Size and 2 x Half-Size Pans
No water connection
Hold and Display Food without the use of water (no water connection required)
Condensation
No condensation build-up on glass
Display
Euro-style Curved Glass (side panels).
Wide-Beam Halogen Lighting
Enhances product view and stimulates sales
Tempered Mirror Sliding Glass Doors
Framed and removable, making display more visible and simplifying the cleaning process
Coated Shatterproof Lighting
Halogens
Rubber Gaskets
Protects the glass edges from chipping
Heavy Duty Construction
Manufactured with high-gauge 304 stainless steel

RESFAB EQUIPMENT INC.

Toll Free: 1-866-359-0808

info@resfab.com | resfab.com

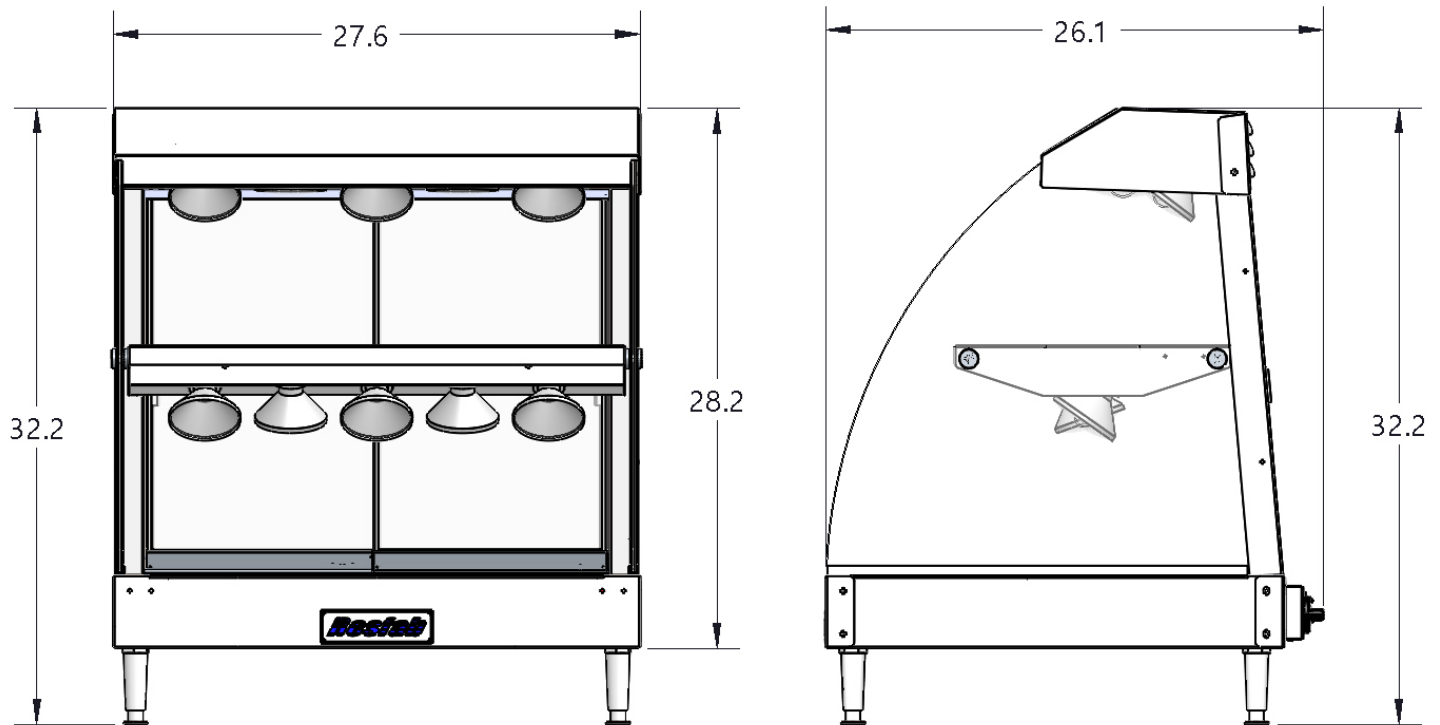

ELECTRICAL

MODEL	GNG-2P2T
VOLTAGE	120 V
AMPERAGE	11.3 A
POWER CORD	10 ft
LIGHT BULBS (HALOGEN)	10 X 50W
PLUG	NEMA 5-15P

DIMENSIONS

WEIGHT	110 lbs
WEIGHT – CRATED	165 lbs
CRATE DIMENSIONS	W 34" x H 40" x D 30"

INSTALLATION REQUIREMENTS

- DISPLAY CASE MUST BE INSTALLED LEVEL
- USE THE 4 LEGS OR SEAL THE CASE TO THE COUNTER WITH NSF FOOD GRADE CAULKING

RESFAB EQUIPMENT INC.

Toll Free: 1-866-359-0808

info@resfab.com | resfab.com