



# Electrolux

## Vegetable Slicer Cutter Slicer - 4.5 QT - Variable Speed

ITEM # \_\_\_\_\_

MODEL # \_\_\_\_\_

NAME # \_\_\_\_\_

SIS # \_\_\_\_\_

AIA # \_\_\_\_\_



Electrolux



600518 (K45YVVU)

Vertical Cutter/Mixer, bench-style, variable speed (300-3700 RPM). Supplied with 4.7 qt removable stainless steel bowl with clear BPA-free lid, equipped with scraper. Microtooth blade rotor and metal motor housing, 1-1/4 HP, NEMA 5-20P

### Short Form Specification

**Item No.** \_\_\_\_\_

Vertical Cutter/Mixer, bench-style, variable speed (300-3700 RPM). Supplied with 4.7 qt removable stainless steel bowl with clear BPA-free lid, equipped with scraper. Microtooth blade rotor and metal motor housing, 1-1/4 HP, NEMA 5-20P

### Main Features

- Delivered with: 1 gallon (4,5 lt) stainless steel cutter bowl, transparent lid, scraper and microtoothed blade rotor.
- Automatic speed limitation according to the selected function (slicer or cutter).
- Emulsifier function (scraper) included as standard.
- All parts in contact with food are removable without the use of tools, completely dismountable and dishwasher safe.
- Pulse function to coarse chopping.
- Base fixed cover for a better handling.
- Capacity: cutter mixer working capacity up to 4lbs (2kg), for 50-80 meals per service.

### Construction

- Asynchronous industrial motor with no brushes for high reliability and quiet functioning, stainless steel motor shaft.
- All blades (available on request) are made in stainless steel and dishwasher safe.
- Metal motor housing.
- Power: TRK45 - 1.3 HP.
- Food processing at 10 variable speeds: 300-3700 rpm.
- Stainless steel bowl has a high chimney to ensure high productivity also when processing liquids (75% of the nominal capacity).
- IPX5 (IP55) flat panel touch-control, waterproof panel.
- Compact and portable design.
- Improved ventilation system to manage smoothly heavy duty use.
- Reinforced feet to withstand the continuous movements of the unit.



APPROVAL: \_\_\_\_\_

Electrolux Professional, Inc.

[www.electroluxusa.com/professional](http://www.electroluxusa.com/professional)

10200 David Taylor Drive, Charlotte, NC 28262 • Telephone Number: 866-449-4200 • Fax Number: 704-547-7401

Vegetable Slicer  
Cutter Slicer - 4.5 QT - Variable Speed



**Electrolux**

# Vegetable Slicer Cutter Slicer - 4.5 QT - Variable Speed

Front

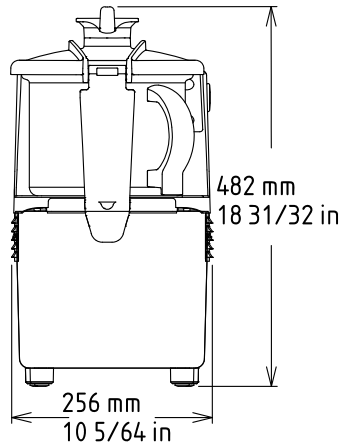

### Electric

<b>Supply voltage:</b>	
600518 (K45YVVU)	110-120 V/1N ph/60 Hz
<b>Total Watts:</b>	1 kW
<b>Plug type:</b>	USA NEMA 5-15P

### Key Information:

<b>External dimensions, Width:</b>	10 1/16" (256 mm)
<b>External dimensions, Depth:</b>	16 5/16" (415 mm)
<b>External dimensions, Height:</b>	19" (482 mm)
<b>Shipping width:</b>	11 13/16" (300 mm)
<b>Shipping depth:</b>	23 5/8" (600 mm)
<b>Shipping height:</b>	21 5/8" (550 mm)
<b>Shipping weight:</b>	55 lbs (25 kg)

Side

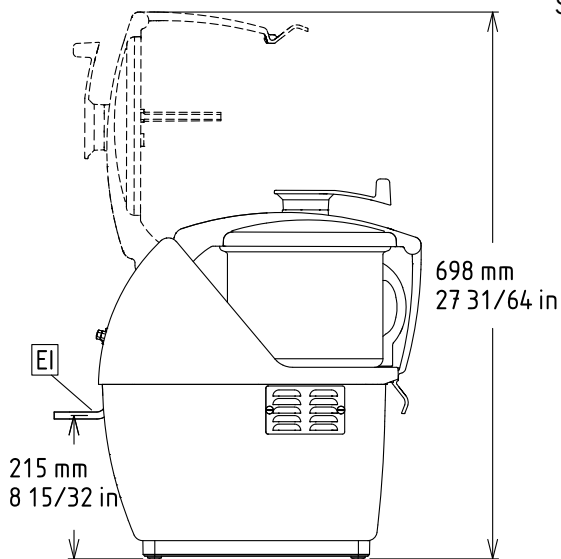

EI = Electrical connection

Top

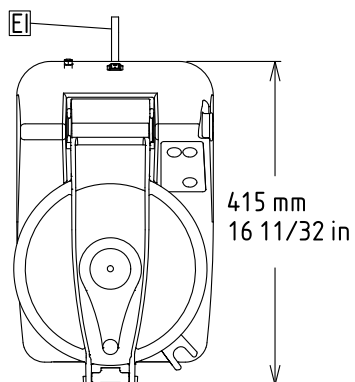



**Electrolux**

**Vegetable Slicer  
Cutter Slicer - 4.5 QT - Variable  
Speed**

**Vegetable Slicer  
Cutter Slicer - 4.5 QT - Variable Speed**

The company reserves the right to make modifications to the products  
without prior notice. All information correct at time of printing.

2018.09.14