

MF 500.2 2T Pass Thru ROLL IN Blast Chiller and Shock Freezer



MultiFresh®: the multi-function assistant that will organize your production and processes with flexibility 24 hours a day.

MultiFresh is the first and only machine in the world that can run operating cycles with temperatures from 185° F to -40° F preserving its consistency, moisture content, and nutritional properties.

Multifunction 7" touchscreen display, product specific cycles, wide range of options, customization of all the parameters for each cycle.

Capacity

Capacity: 2 x Combi Oven Trolley (sized for 18"x26" pans)

Capacity: 4 x SLIM Rack (sized for 12"x20" pans)

Yield

Blast chilling capacity (194F to +37°F) 1103 Lbs (within 90 min or less)

Shock freezing capacity (194F to 0°F) 1103 Lbs. (within 240 min or less)

Product Warranty Protection

- 2 years, parts and labor.
- 5 years, compressor.

Certification



Standard Construction Features

- CABINET + REMOTE CONDENSING UNIT.
- All type 304 stainless steel construction
- CFC-free high-density polyurethane insulation
- Full width door with low-temperature resistant magnetic gasket
- MultiSensor® 5-point probe for perfect temperature control.
- Automatic switch from manual mode (timed) to automatic mode (with probe) when probe is not inserted
- Approved 404a refrigerant used in sealed system
- High efficiency evaporators with multiple injection points
- Data port & Wi-Fi capable data transfer to HACCP software
- Door hinged right (standard)
- End-of-cycle hold mode
- Self-contained, air-cooled energy efficient condensing unit
- Manual defrosting required at the end of the day
- SANIGEN sanitation system
- 2-1/4" thick insulated floor
- Sunken Floor.
- Drain on left side (different position on request).

Unique Design and Performance Features

- 4 cycles in standard mode, 43 product specific cycles in dynamic mode; ability to record up to 20 replicable cycles into customized recipe book
- Indirect air distribution and special airflow pattern to ensure perfect temperature uniformity
- Moisture preservation system by "delta-t" control.
- MultiFresh® touch screen
- Smudge-resistant controller touch pad
- Easily accessible evaporators and waterproof fans
- 30-40% more energy efficient than average competitor models with faster chilling times, all while preserving freshness, fragrance and organic properties of the food

Option and Accessories

- Door hinged left
- Ramp
- Sous-vide core probe
- 120° or 100° Door Stop
- Knocked down
- City line or Water Tower Remote Condensing unit
- Pass thru version
- Mirror Unit
- Additional core probe

- Available PLUS model version with heat cycles: THAWING, HOLDING (hot or cold), REGENERATION, PASTEURIZATION, PROOFING, LOW TEMPERATURE COOKING

CABINET

FRONT VIEW

SIDE VIEW

TOP VIEW

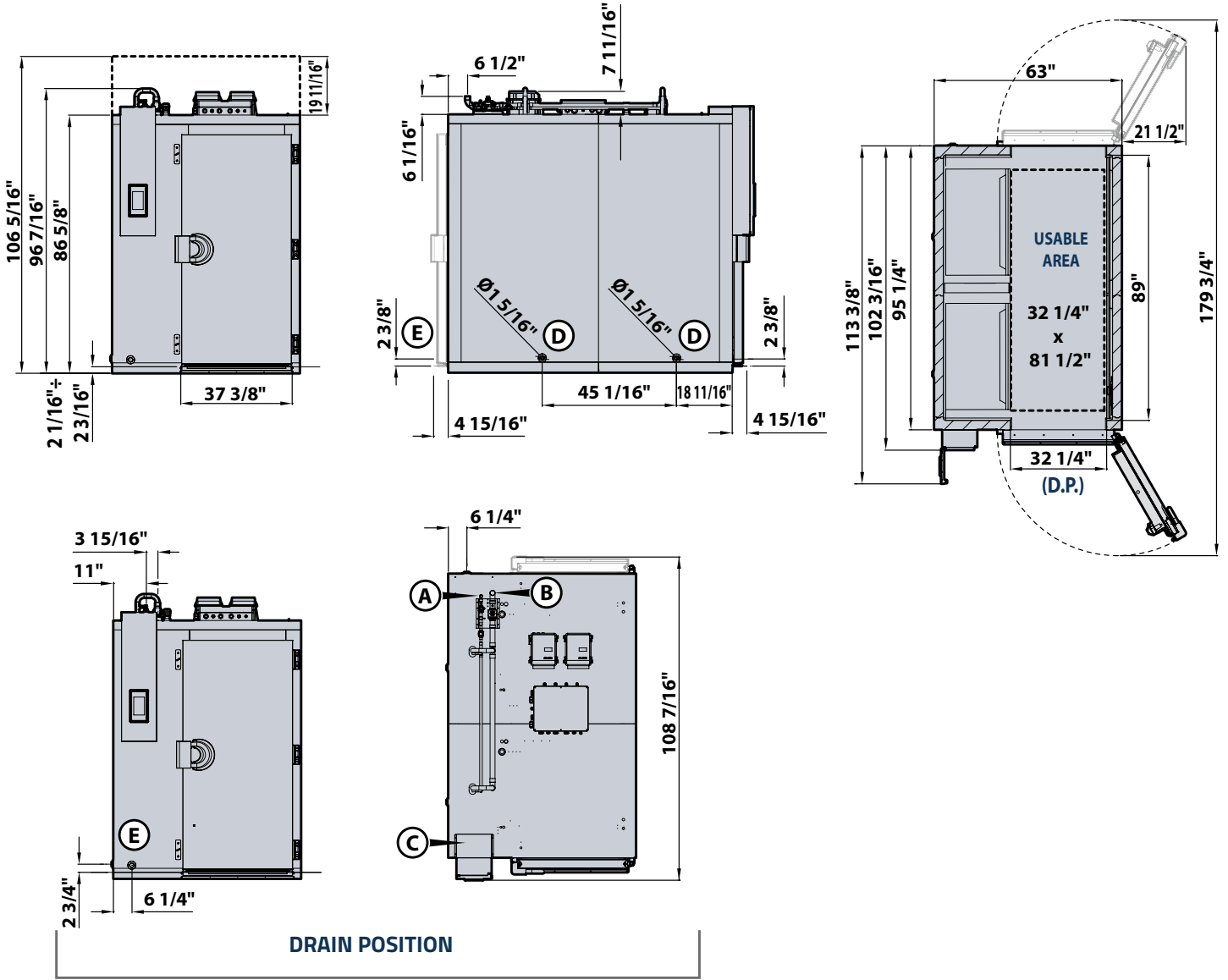

GENERAL CHARACTERISTICS

(A)	Liquid line connection		
(B)	Suction line connection		
(C)	Communication power cable inlet		
(D)	Standard drainage discharge	\varnothing In (ømm)	1" 1/4 DN32
(E)	Drainage discharge on request	\varnothing In (ømm)	1" 1/4 DN32

(D.P.) = Door passage

The back door is optional and on request

STANDARD PACKING

Gross Weight	Lb	2095
Dimensions (W x D x H)	In	115 x 68" 8/9 x 100" 2/5 x N° 1
Volume	ft³	460,09

TECHNICAL DATA

Electric supply:		208V-3+PE 60Hz	
Variants		Standard	PLUS
Total rating (FLI)	kW	6,70	22,20
Full load amps (FLA)	A	20,90	62,00
Main power cable	AWG	4G8	4G2
Section of electrical cable between cell and unit	AWG	7×15	
Refrigerant type:		R404A	
Maximum ambient air temperature:	°F	90	
Cabinet weight:	Lb	1764	
Effective internal Cell volume	ft ³	124	
Base with feet option		x	
Maximum height of the cell with feet	In	-	
Feet height	In	- - -	
Sunken floor option		✓	
Maximum height of the cell with sunken floor	In	94" 2/7	
Pit Dimensions(Sunken Floor Version) W x D x H	In	63" 2/5 × 95" 2/3 × 2" 1/6	
Floor with ramp option		✓	
Maximum height of the cell with ramp	In	96" 1/2	
Ramp length	In	23" 5/8	
Ramp height	In	2" 2/7	
Ventilated floor with ramp option		✓	
Maximum height of the cell with ramp and ventilated floor	In	97" 1/4	
Ramp length	In	23" 5/8	
Ramp height	In	2"x 2/7	

TUBES CONNECTING TO THE CONDENSING UNIT

Liquid Line Connection	øIn (ømm)	1" 1/8 (28.58 mm)
Suction line connection	øIn (ømm)	2" 1/8 (53.97 mm)
Valid for condensing units installed up to a distance of	ft	82,0

BLAST CHILLER SIZE

Yield for blast chilling cycle: (194/+37°F)	Lb	1103
Yield for shock freezing cycle: (194/-0°F)	Lb	1103

*: within 90 min. **: within 240 min.

UNIT

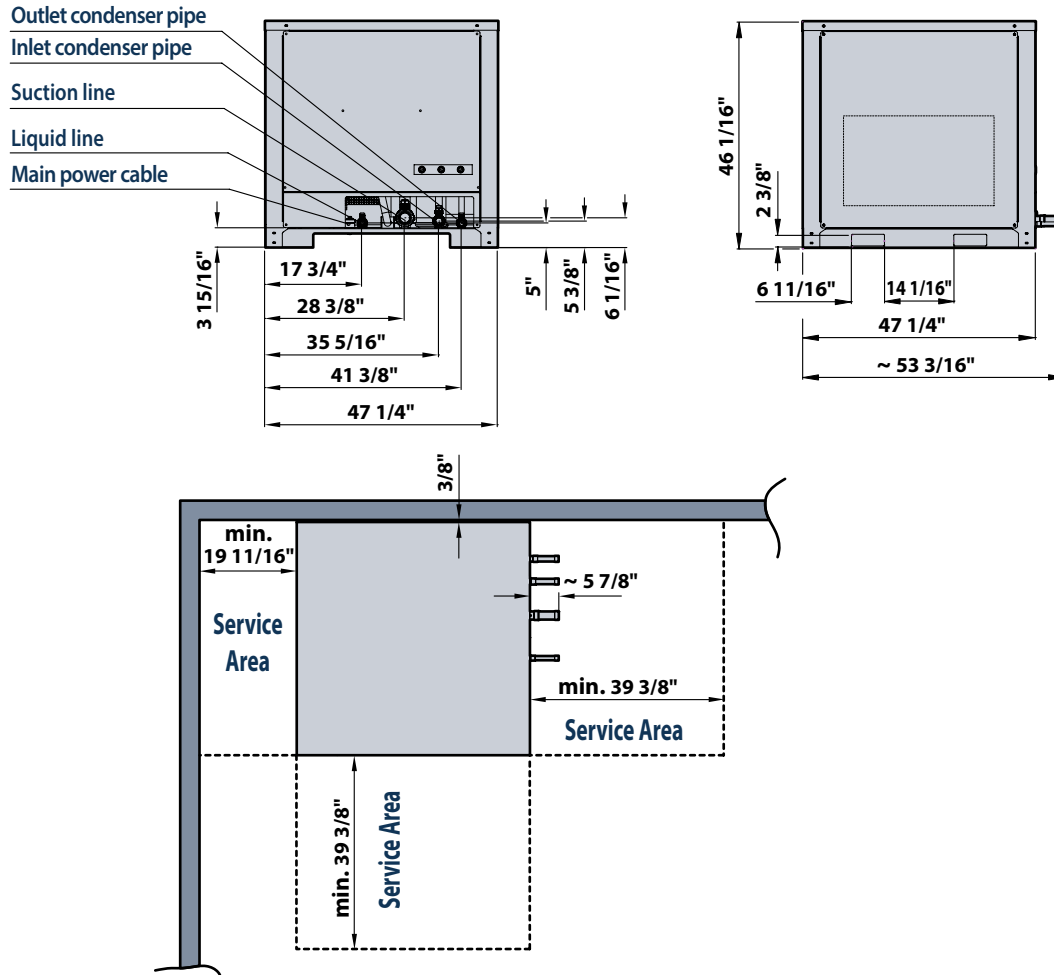

CAPACITY OF THE CONDENSING UNIT

Yield for blast chilling cycle: (194/+37°F)	Lb	1103
Yield for shock freezing cycle: (194/-0°F)	Lb	1103

*: within 90 min. **: within 240 min.

STANDARD PACKING

Gross Weight	Lb	1054
Dimensions (W × D × H)	In	58" 2/3 × 58" 2/3 × 68" 8/9 × N° 1
Volume	ft ³	137,00

TECHNICAL DATA

Electric supply:		208V-3+PE 60Hz
Total rating (FLI)	kW	49,50
Full load amps (FLA)	A	159,70
Start electrical absorption (RLA)	A	330,00
Main power cable	AWG	4G2/0
Cabinet / condensing unit connection cable	AWG	7×15
Cable section of the electrical connection between unit and condenser	AWG	8 × 1.5 + PE
Compressor rating	HP	35
Refrigeration Yield (14/104 °F)	btu/h	253363
Condenser rating (14/104 °F)	btu/h	348161
Refrigerant type:	-	R404A
Refrigerant PRE-load	oz. gas	846,5
Liquid Line Connection	øIn (ømm)	1" 1/8 (28.58 mm)
Suction line connection	øIn (ømm)	2" 1/8 (53.97 mm)
Inlet remote condenser line	øIn (ømm)	1" 3/8 (34.93 mm)
Outlet remote condenser line	øIn (ømm)	1" 1/8 (28.58 mm)
Compressor displaced volume	ft ³ /h	4710,35
Maximum ambient air temperature:	°F	108
Remote unit weight:	Lb	915
Oil Charge	gal	-
Compressor Noise (3,28 ft)	dB(A)	62,0

CONDENSER

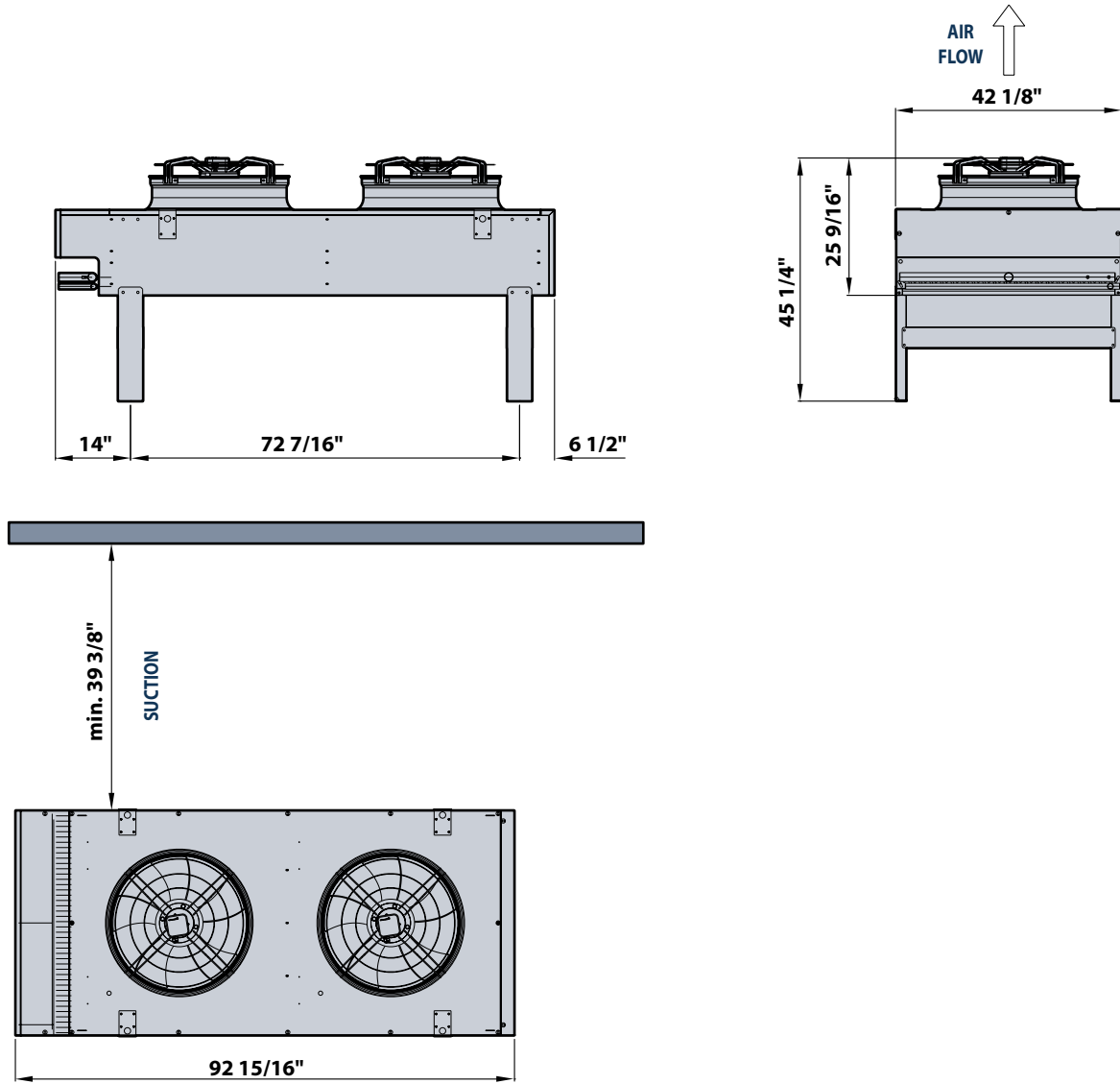

REMOTE CONDENSER

Mains frequency:	-	50 Hz	60 Hz
Condenser noise (max) 32.8 ft	dB(A)	-	61,0
Total air flow:	ft ³ /h	-	891224
Fan Quantity			-
Maximum ambient air temperature:	°F		108
Refrigerant type:	-		R404A
Condenser weight:	Lb		472

STANDARD PACKING

Gross Weight	Lb	662
Dimensions (W x D x H)	In	105 x 31 x 54 x N° 1
Volume	ft ³	99,57

Continued product development may necessitate specification changes without notice.

Irinnox North America

9990 NW 14th Street Suite 107 Miami FL 33172

Phone. (786) 870 5064 Fax. (786) 391 2467

www.irinnoxprofessional.com/usa/ | info@irinnoxnorthamerica.com