

Slim Line - Direct Draw Beer Coolers

FDD-24 Series



Item # _____

FDD-24-48-HC FDD-24-60-HC FDD-24-72-HC
FDD-24-48S-HC FDD-24-60S-HC FDD-24-72S-HC

Standard Features

- Our Slim Line direct draw units have been completely redesigned to be fully front breathing, able to handle those tight bar applications and extreme **100 °F environments**.
- Refrigeration system is a free flowing air system throughout the box to ensure "ICE COLD" products at all times with a side mount evaporator system.
- With innovative and eco-friendly technology, Fagor utilizes R-290 Hydrocarbon designed to meet DOE's Energy Conservation standards with very low contribution to global warming (ODP-0) (GWP-3).
- Heavy duty 18 gauge stainless steel top, durable stainless steel inside walls and coved corner floor. Reinforced bottom door frame to protect your long term investment.
- Polymer "**Dunnage style**" removable protective floor for extended life of your box and designed for greater air flow underneath your kegs.
- 3" diameter polished stainless steel draft tower with more taps per tower, standard. Cold air into the towers is designed thru our unique forced air design which provides you with the most air flow into your towers than anyone in the industry.
- Field interchangeable doors from Solid to Glass or Glass to Solid to adapt to ever changing needs.
- Units come with compressor mounted on the left side with service friendly slide out rail system. Drain is located in the back compressor housing away from your customer's line of sight.
- **LED light** underneath the mullion to protect itself from normal operations.



FDD-24-48-HC



FDD-24-60S-HC



FDD-24-72-HC

Options & Accessories

- 3" castors
- 6" adjustable stainless steel legs
- Single / Double draft towers
- 220 volts / 50 cycles / 1 phase



*Conforms to UL & NSF-7 standards

Direct Draw	Model	Doors	Towers	Taps	Kegs	Amp	HP	Volt	NEMA Plug	Cabinet Dimensions W / D / *H			Shipping (Wt. Cubes)	
	FDD-24-48-HC	2	1	2	2	2	2.0	1/4	115	5-15P	49-5/8"	24"	35-1/2"	235
FDD-24-60-HC	2	2	3	3	3	2.0	1/4	115	5-15P	62-1/4"	24"	35-1/2"	290	41
FDD-24-72-HC	2	2	3	3	3	2.0	1/4	115	5-15P	72"	24"	35-1/2"	340	48
FDD-24-48S-HC	2	1	2	2	2	2.0	1/4	115	5-15P	49-5/8"	24"	35-1/2"	235	33
FDD-24-60S-HC	2	2	3	3	3	2.0	1/4	115	5-15P	62-1/4"	24"	35-1/2"	290	41
FDD-24-72S-HC	2	2	3	3	3	2.0	1/4	115	5-15P	72"	24"	35-1/2"	340	48

*Height does not include towers. (S) Stainless steel units / (G) Glass door units.

JULY 2021

13105 NW 47th Ave. Opa-Locka FL 33054
 Tollfree: (866) 463 2467 Ph: (305) 779 0170 Fax: (305) 779 0173
 info@fagorcommercial.com
 www.fagorcommercial.com

TOGETHER WE EVOLVE

Slim Line - Direct Draw Beer Coolers

FDD-24 Series



Specifications

Construction

Heavy duty stainless steel top, 18 gauge. Black vinyl front, sides and back. (S) Models have stainless steel front and sides. Galvanized back panel. Interior constructed of heavy duty stainless steel walls with coved corner NSF approved stainless steel floor. Reinforced polymer removable protective floor. Door is comprised of heavy duty black vinyl steel. (S) Models are stainless steel. Provided with locks per door, magnetic door gaskets, removable without tools. Door openings have a plastic breaker strips to retard condensate formation. Units come complete with a 2" Ecomate CFC-Free polyurethane insulation, foamed in place.

Refrigeration system

Self-contained capillary tube system using environmentally friendly (CFC Free) R-290 refrigerant. Front breathing compressor on left side for built-in applications. Evaporator coil is mounted to interior left side above the compressor. Large fan motor and fan blades for greater air flow. Automatic condensate evaporator, no drain connection required. Evaporator condensate has been plumbed to a condensate pan located in the compressor housing.

Access for the condensing unit behind the front grill, slides out for easy cleaning and maintenance.

Cabinets are designed to maintain temperatures between 33 °F to 38 °F in the interior cabinet.

Lights

Interior LED light underneath the mullion.

Others

Unit is supplied standard with an 8' cord and plug (Nema 5-15p). 48" has (1) 2 way CO2 valve, 60" has (1) 3 way CO2 valve & 72" has (1) 4 way CO2 valve. Drain is located in the back inside compressor housing.

Warranty

3 year parts and labor warranty plus 2 additional year compressor warranty. (Continental U.S.A. & Canada only).

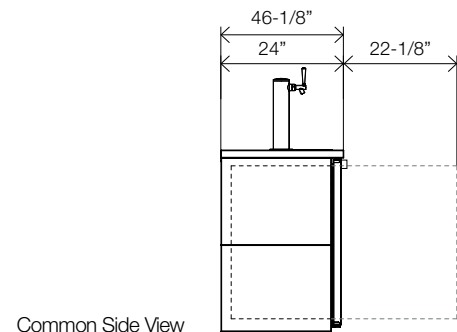
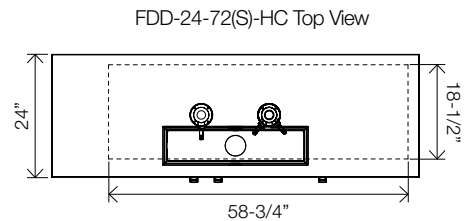
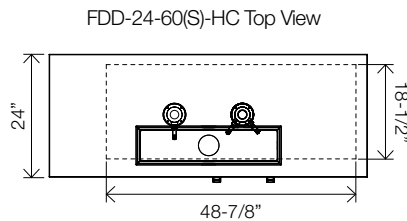
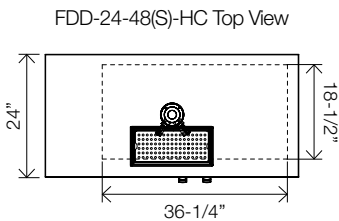
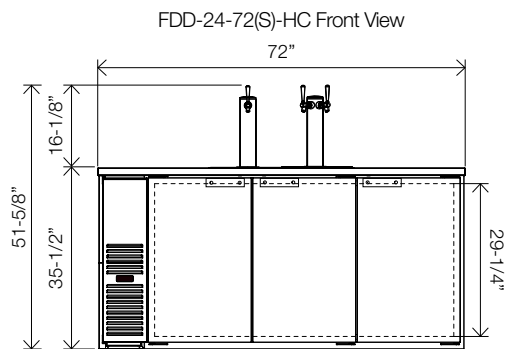
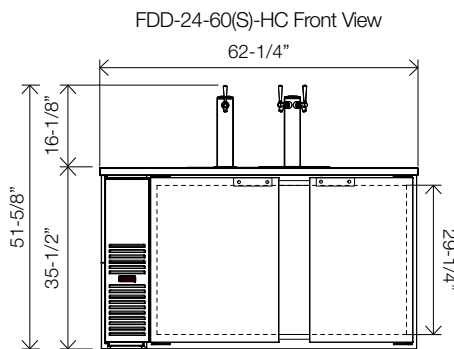
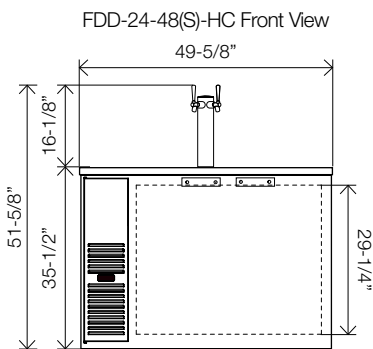

The manufacturer reserves the rights to modify materials and specifications without notice.

JULY 2021

13105 NW 47th Ave. Opa-Locka FL 33054
 Tollfree: (866) 463 2467 Ph: (305) 779 0170 Fax: (305) 779 0173
 info@fagorcommercial.com
 www.fagorcommercial.com

TOGETHER WE EVOLVE