

REFRIGERATOR MANUFACTURER
Turbo air
 more durable, efficient, beautiful

4184 E. Conant St.
 Long Beach, CA 90808
 Tel. 310-900-1000
 Fax. 310-900-1077
www.turboairinc.com

Project :	
Model # :	
Item # :	Qty :
Available W/H :	
Approval :	

Sandwich & Cheese Display Cases

Open Display
Merchandisers

Patented Self-Cleaning Condenser



This product is equipped with a fine mesh filter to the front of the condenser to catch dust, and a rotating brush that moves up and down daily to remove excess buildup outward and away.

Model : TOS-40NN-W(B)



TOS-40NN-W



TOS-40NN-B

≡ FEATURES & BENEFITS ≡

■ **Self-Cleaning Condenser**

The accumulation of dust in the condenser can cause the failure or breakdown of refrigerators. Refrigerators run normally until they reach a certain level of accumulation. At some point, when they are over the limit, their performance drops quickly resulting in damage to, or disposal of the stored products inside. The Self-Cleaning Condenser device keeps the condenser clean and prevents system failure by automatically brushing daily.

■ **Hydrocarbon refrigerants (R-290)**

With innovative and eco-friendly technology, Turbo Air brings you hydrocarbon refrigerators designed to meet DOE's Energy Conservation Standards in 2017 and to use EPA's SNAP Program approved HC refrigerants. Hydrocarbon refrigerants do not deplete the ozone layer and have very low contribution to global warming (ODP-0, GWP-3).

■ **High-density polyurethane insulation**

The entire cabinet structure is foamed-in-place using high density, CFC free polyurethane insulation.

■ **Digital temperature controller**

■ **Single pane glass is tempered for safety**

■ **Stainless steel floor and airflow grille**

■ **Self-contained system, no plumbing required**

NATURAL Refrigerant



Model	CU./FT.	HP	AMPS	Crated Weight (lbs.)	L x D x H* (inches)
TOS-40NN-W(B)	3.3	1/3	5.3	552	40 x 35³/₈ x 30⁷/₈

Sandwich & Cheese Display Cases

Open Display Merchandisers

Model : TOS-40NN-W(B)

ELECTRICAL DATA	
Voltage	115/60/1
Plug Type	 NEMA 5-15P
Full Load Amperes	5.3
Compressor HP	1/3
Cord Length (ft.)	8 1/4
Refrigerant	R-290
DIMENSIONAL DATA	
Net Capacity (cu. ft.)	3.3
Ext. Length Overall (in.)	40 (1015mm)
Ext. Depth Overall (in.) *	35 3/8 (900mm)
Ext. Height Overall (in.)	30 7/8 (783mm)
Int. Length Overall (in.)	35 3/8 (900mm)
Int. Depth Overall (in.)	25 1/4 (641mm)
Int. Height Overall (in.)	6 1/2 (164mm)
Net Weight (lbs.)	375
Gross Weight (lbs.)	552

Design and specifications subject to change without notice.

Actual shipping weight may differ due to extra packing materials for product protection.

* Height does not include 2-1/4" for caster height.

- **WARRANTY : 2 Year Parts and Labor Warranty**
Additional 3 Year Warranty on Compressor

STANDARD FEATURES

- White and black color come standard
- 3" dia. swivel casters with locks on the rear set

** Lead time applies. Please contact your sales representative for more details to order.

Recommended operating conditions

TOS models are designed to operate in an environment where temperature & humidity do not exceed 75°F and 55% respectively.

PLAN VIEW

(unit : inch)

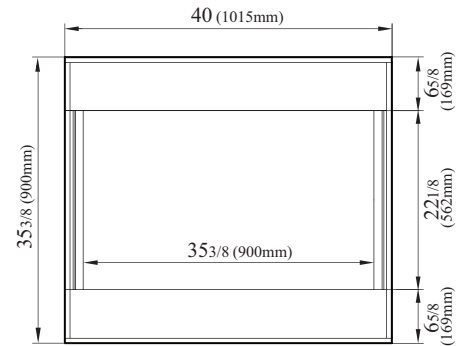

TOP VIEW

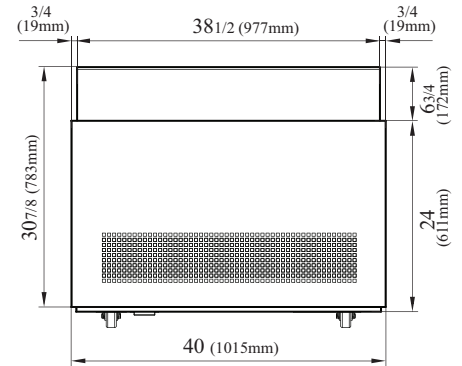

FRONT VIEW

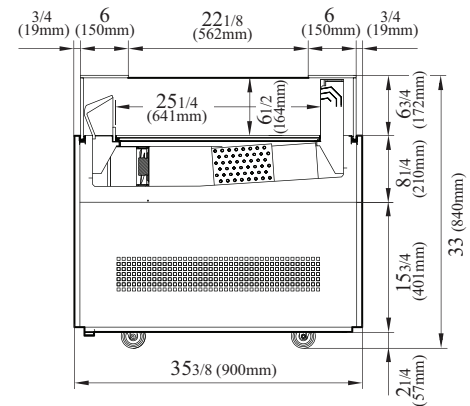

SIDE VIEW

Ver.20200508



- Turbo Air : 800-627-0032
- GK : 800-500-3519
- Warranty : 800-381-7770
- AC : 888-900-1002

REFRIGERATOR MANUFACTURER
Turbo air

GERMAN
KNIFE

RADIANCE

REFRIGERATION SYSTEM
Turbo air

TEXAKING