

## P120E "A"

Modular electric oven for pizzeria

COMPOSITION WITH 1 BAKING CHAMBER



### OPTIONS AND ACCESSORIES (WITH SURCHARGE)

- Leavening prover on wheels, height 800mm (31 1/2")
- Support with wheels, height 600mm (23 1/2")
- Support with wheels, height 800mm (31 1/2")
- Support with wheels, height 950mm (37 1/2")
- Additional tray holder guides for compartment and support
- Spacer element height 300mm (12")
- Suction hood

### (WITHOUT SURCHARGE)

- Front vapour collection hood in stainless steel sheet

### EXTERNAL CONSTRUCTION

- Structure made in folded stainless steel
- Side panels in pre-painted sheet metal
- Stainless steel hood with aluminised steel top cover
- Front vapour collection hood in HT coating steel sheet
- Steam duct in stainless steel plate
- Stainless steel double door with bottom hinge and spring balance
- Tempered glass element
- Handles in thermoplastic material
- Control panel on front right hand side

### INTERNAL CONSTRUCTION

- Refractory brick cooking surface
- Aluminated steel top and side structure
- Rock wool heat insulation

### FUNCTIONING

- Heated by armoured heating elements
- Electronic temperature management with independent adjustment of ceiling and floor
- Maximum temperatura reached 450°C (840°F)
- Continuous temperature monitoring with thermocouple
- Vapour ducting using manual butterfly valve

### STANDARD EQUIPMENT

- Lighting with halogen lamp
- Timer
- Economiser
- Independent maximum temperature safety device
- 20 customisable programs



**MORETTI FORNI S.P.A.**

[www.morettiforni.com](http://www.morettiforni.com)

[info@morettiforni.com](mailto:info@morettiforni.com)

Via A.Meucci, 4 - 61037 Mondolfo (PU) ITALIA

Tel. +39.0721.96161 - Fax +39.0721.9616299



## P120E "A"

### 1 baking chamber height 18cm (7")

(assembled with support height 950mm (37 1/2"))

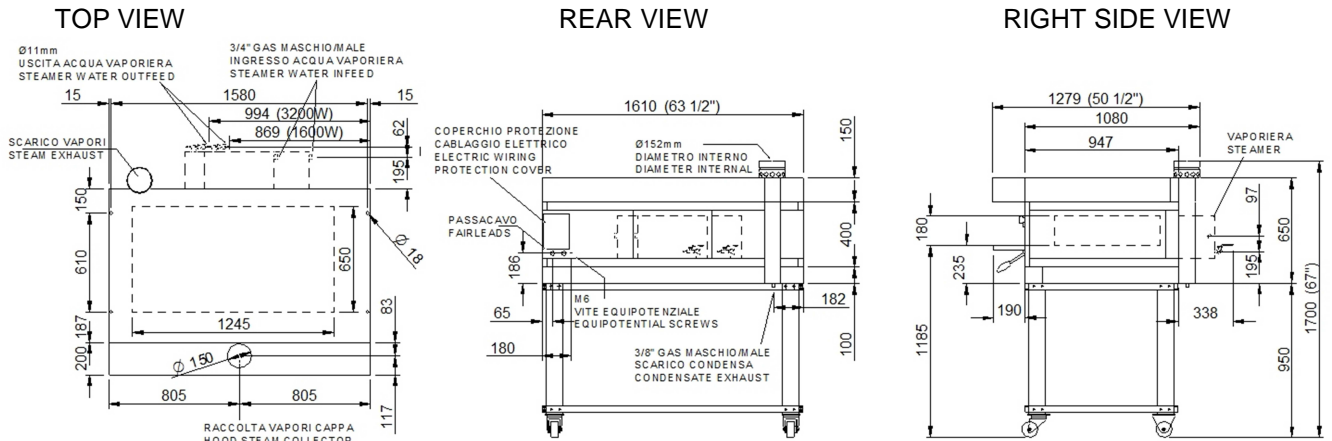

**Note:** The dimensions indicated in the views are in millimeters. Steamer for Bakery only.

### SPECIFICATIONS

The appliance comprises one cooking element and an optional leavening compartment or support. The oven cooking surface is made of refractory, allowing perfect heat distribution over the whole surface and making this oven particularly suitable for use by pizza cooks. Temperature adjustment is electronic, with independent control of the ceiling and floor heating elements. The oven door is hinged at the bottom, with a tempered glass window to check the state of the product while it is cooking. The support comprises a painted metal structure, whereas the leavening compartment has a stainless steel structure and is fitted with a heating thermostat. The leavening compartment can reach a maximum temperature of 65°C (150°F), whereas the maximum temperature of the baking chamber is 450°C (840°F)

All the data provided below refer to the configuration with 1 baking chamber

### DIMENSIONS

|                 |  |
|-----------------|--|
| External height | 1700mm (67")                             |
| External depth  | 1279mm (50 1/2")                         |
| External width  | 1610mm (63 1/2")                         |
| Weight          | 237kg (523lb)                            |
| Baking surface  | 0,8m <sup>2</sup> (8,61ft <sup>2</sup> ) |

### SHIPPING INFORMATION

|                        |                 |
|------------------------|-----------------|
| Packed in wooden crate |                 |
| Height                 | 900mm (36")     |
| Depth                  | 1452mm (58")    |
| Width                  | 1810mm (72")    |
| Weight                 | (287)kg (633)lb |

### FEEDING AND POWER

|                                |        |
|--------------------------------|--------|
| <i>Standard feeding</i>        |        |
| A.C. V240 3ph                  |        |
| <i>Feeding on request</i>      |        |
| A.C. V208 3ph                  |        |
| Frequency                      | 60Hz   |
| Max power                      | 9,4kW  |
| *Average power cons            | 4,7kWh |
| Ampère Max                     |        |
| 22,6A (V240 3ph)               |        |
| 26,1A (V208 3ph)               |        |
| Connecting cable               |        |
| (8AWG)                         |        |
| Power supply (optional prover) |        |
| A.C. V(208/240) 1ph 60 Hz      |        |
| Max power                      | 1,8kW  |
| *Average power cons            | 0,9kWh |
| Conn. Cable (14AWG)            |        |

### TOTAL BAKING CAPACITY

|                            |   |
|----------------------------|---|
| Tray (600x400)mm           | 3 |
| Tray 26"x18"               | 2 |
| Pizza diameter 300mm (12") | 8 |
| Pizza diameter 450mm (18") | 2 |

|  |                 |
|--|-----------------|
| When combined with leavening compartment or support: |                 |
| Max height   | 1850mm (73")    |
| Max weight   | (388)kg (856)lb |

\* This value is subject to variation according to the way in which the equipment is used

- NOTE: MORETTI FORNI S.P.A. reserves the right to modify the characteristics of the products illustrated in this publication without prior notice