



# TURBO LIQUIDISER TRX-22 220/60/3 (BY AIR)

2-speed turbo-mixer.



DYNAMIC PREPARATION  
TURBO LIQUIDISERS

P/N. 3030505



- ✓ For use with 3 easily interchangeable attachments, which meet the needs of all users and ingredients.
  - 21D for fibrous ingredients
- ✓ Standard 30D multi-use attachment
- ✓ 42D attachment for very fine blending
- ✓
- ✓ Safety microswitch to control the work position: prevents the turbine working if the arm is too high or low.
- ✓ Safety guard on the liquidiser head and safety device that cuts out the power supply.

## INCLUDES

- ✓ Trolley, motor and arm (without grids).

## OPTIONS

- 21D attachment for fibrous ingredients.  general use.
- Standard 30D attachment for  42D attachment for very fine blending.

## ACCESSORIES

- Grids for TRX

## SPECIFICATIONS

Maximum recipient capacity: 800 l / 130 gal.

Liquidising arm length: 24 "

Total loading: 3 Hp

Speed (in liquid): 1500 rpm

Electrical supply: 220V / 60 Hz / 3~ (9.7A)

Electrical supply: 220 V / 60 Hz / 3 ~ (8.2-7.1 A)

Plug:-

Electrical connection: 3P+G

### External dimensions (WxDxH)

✓ Width: 22 "

✓ Depth: 65 " (37 ")

✓ Height: 48 " (65 ")

Net weight: 212 lbs

### Crated dimensions

68.9 x 40.9 x 31.9 "

Gross weight: 388.0 lbs.

## SALES DESCRIPTION

- ✓ Turbo-blender designed to work in up to 800 litre / 130 gal. bowls.
- ✓ For mixing and liquidising directly in the pot or pan for making consommés, soups, omelettes, mayonnaise, etc.
- ✓ Designed for large yields and for frequent use and cleaning, ideal for kitchens with a large production and the food industry.
- ✓ 2-Speed model.

- ✓ Fully manufactured in stainless steel 18/10.
- ✓ Ease of use: can be moved in several directions, adjustable height, fitted on a trolley with 4 non-slip rubber wheels, 2 of them with brakes.
- ✓ Arm: 600 mm long for blending in any type of cooking pot, whether round or rectangular, equally effective throughout the whole pot.
- ✓ Balanced liquidiser arm: stops the arm falling or tipping back when not locked.
- ✓ Arm securing lever: allows you to lock the blender with one hand while holding the trolley with the other.
- ✓ Watertight, tilted control panel: easy access even during use.
- ✓ Control panel located on the trolley, making the arm more agile, with better mobility.
- ✓ Control panel with built-in timer: you can leave the machine running for up to 60 minutes without the need for user involvement.
- ✓ Wiring incorporated into the trolley tubes: The work area is free of cables, so as not to hinder the movement of the blender arm.
- ✓ Supports for storing the power supply cable: prevents the cable getting tangled and inconveniencing other users.
- ✓ The turbine, disc and grille are very easy to remove for cleaning: no tools needed. The turbine, guard, disc and attachment can be cleaned in dishwashers.



product sheet  
updated 11/04/22



# TURBO LIQUIDISER TRX-22 220/60/3 (BY AIR)

2-speed turbo-mixer.



P/N. 3030505

DYNAMIC PREPARATION  
TURBO LIQUIDISERS

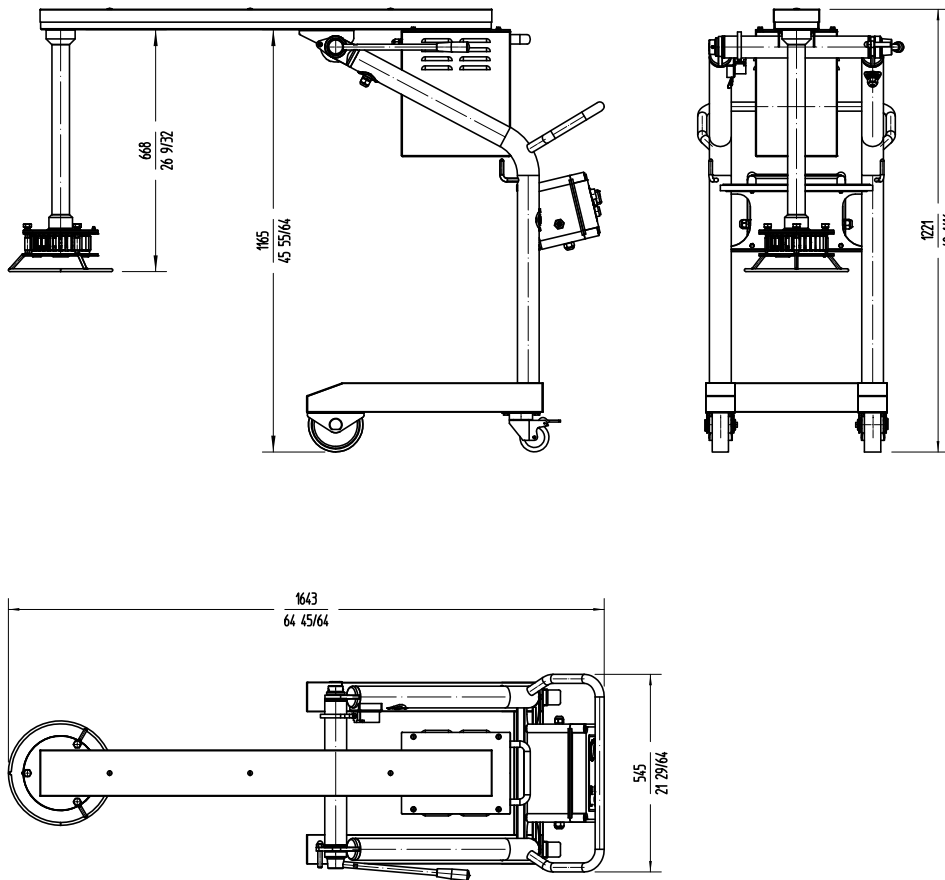

**sammic** | [www.sammic.us](http://www.sammic.us)  
Food Service Equipment Manufacturer

[usa@sammic.com](mailto:usa@sammic.com) phone +1 (224) 307-2232  
1225 Hartrey Avenue toll free +1 844 275 3848  
60202-1056 Evanston, IL



Project	Date
Item	Qty
Approved	

product sheet  
updated 11/04/22