



MODEL MARK V-100

Full-Size Standard Depth Electric Convection Oven

(Formerly called Mark V)



Shown with optional casters

OPTIONS AND ACCESSORIES

(AT ADDITIONAL CHARGE)

- **Control options:**
 - SSI-D - Solid state infinite control w/digital timer
 - SSI-M - Solid state infinite control w/manual timer
 - SimpleTouch - NEW touchscreen control with ability to store and group recipes. Includes rack timing, Cook&Hold, Fan Delay, Fan Pulse, easy download for recipe writing on your laptop, and HACCP storage capability
- **Legs/casters/stands:**
 - 6" (152mm) seismic legs
 - 6" (152mm) casters
 - 4-1/4" (108mm) low profile casters (double only)
 - 25" (635mm) stainless steel stand w/rack guides
 - 29" (737mm) stainless steel, fully welded, open stand with pan supports
- Stainless steel oven liner
- Extra oven racks
- Solid stainless steel back
- 440 volt, 3 phase
- 480 volt, 3 phase
- Prison package (includes security control panel and stainless steel back)
- Vent connector

OPTIONS AND ACCESSORIES

(AT NO CHARGE)

- Solid stainless steel doors

Project _____

Item No. _____

Quantity _____

Standard depth baking compartment - accepts five 18" x 26" standard full-size baking pans in left-to-right positions.

All data is shown per oven section, unless otherwise indicated.

Refer to operator manual specification chart for listed model names.

EXTERIOR CONSTRUCTION

- Full angle-iron frame
- Stainless steel front, top and sides
- Dual pane thermal glass windows encased in stainless steel door frames
- Powder coated door handle with simultaneous door operation
- Triple-mounted pressure lock door design with turnbuckle assembly
- Modular slide out front control panel for easy access
- Solid mineral fiber insulation at top, back, sides and bottom

INTERIOR CONSTRUCTION

- Double-sided porcelainized baking compartment liner (14 gauge) for easy cleaning
- Aluminized blower wheel
- Five chrome-plated racks, eleven rack positions with a minimum of 1-5/8" (41mm) spacing
- Interior halogen lights

OPERATION

- Three tubular heaters
- Solid state thermostat with temperature control range of 200°F (93°C) to 500°F (260°C)
- Two speed fan motor
- 1/2 horsepower blower motor with automatic thermal overload protection
- Control area cooling fan
- Two halogen oven lamps

STANDARD FEATURES

- SSD - Solid state digital control with LED display, Cook & Hold and Pulse Plus®
- 25" (635mm) adjustable stainless steel legs (for single units)
- 6" (152mm) adjustable stainless steel legs (for double sections)
- Three year parts and two year labor warranty
- Five year limited oven door warranty*

* For all international markets, contact your local distributor.



Intertek

BLODGETT OVEN COMPANY

www.blodgett.com

42 Allen Martin Drive, Essex Junction, VT 05452

Phone: (802) 658-6600 • Fax: (802) 864-0183

MARK V-100



MARK V-100

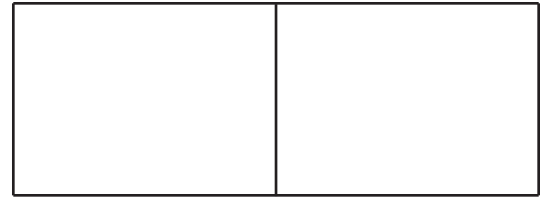

APPROVAL/STAMP

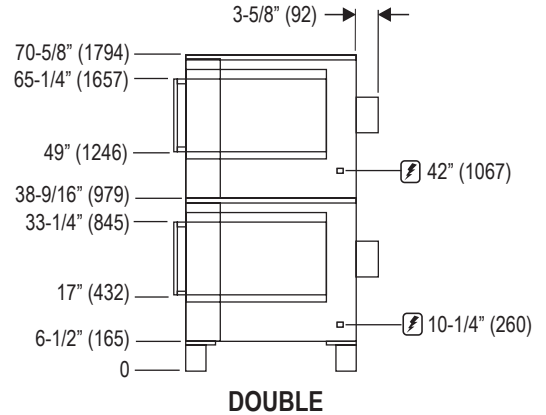
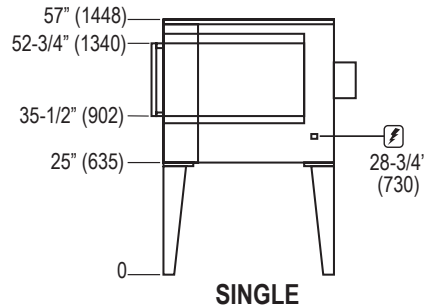
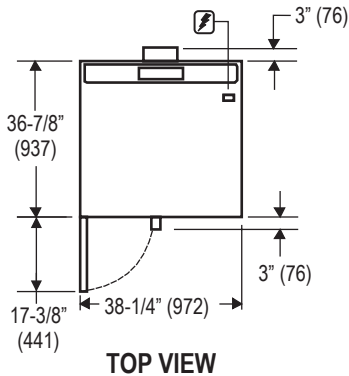

SHORT FORM SPECIFICATIONS - Provide Blodgett full-size convection oven model MARK V-100, (single/double) compartment. Each compartment shall have (porcelainized/stainless) steel liner and shall accept five 18" x 26" standard full-size bake pans. Doors shall (be solid stainless steel/ have dual pane thermal glass windows) with single powder coated handle and simultaneous operation. Unit shall be electrically heated with three tubular heaters. Air in baking chamber distributed by single inlet blower wheel powered by a two-speed, 1/2 HP motor with thermal overload protection. Each chamber shall be fitted with two halogen lamps, five chrome-plated removable racks and removable crumb trays. Control panel shall be recessed with solid state digital control with LED display, Cook & Hold and Pulse Plus. Provide three year parts, two year labor and five year door warranty. Provide options and accessories as indicated.

DIMENSIONS:

- Floor space:** 38-1/4" (972mm) W x 36-7/8" (936mm) L
Product clearance: 1/2" from combustible and non-combustible construction.
Interior: 29" (737mm) W x 20" (508mm) H x 24-1/4" (616mm) D
If oven is on casters:
 Single Add 4-1/2" (114mm) to all height dimensions
 Double Dimensions do not change
 Double Low Profile Subtract 2-1/2" (64mm) from all dimensions

MAXIMUM INPUT:

- Single 11KW
 Double 22KW (11KW each section)

MINIMUM ENTRY CLEARANCE:

- Uncrated 28-7/8" (733mm)
 Crated 34-1/16" (876mm)

SHIPPING INFORMATION:

- Approx. Weight:**
 Single 490 lbs. (222 kg)
 Double 1020 lbs. (463 kg)

- Crate sizes:**
 37-1/2" (952mm) x 43-1/2" (1105mm) x 51-3/4" (1315mm)
 (2 crates required for double)

NOTE: The company reserves the right to make substitutions of components without prior notice

POWER SUPPLY:

V.A.C.	Hz	Phase	K.W.H.	Amperes (L1-L2-L3)
208	60	1	11	51/0/51
208	60	3	11	31/29/29
220/240	60	1	11	44/0/44
220/240	60	3	11	26/24/24
440	60	3	11	15/14/14
480	60	3	11	14/13/13

1/2 H.P., 2 speed motor, 1120 and 1710 RPM (60Hz.)

V.A.C.	Hz	Phase	K.W.H.	Amperes (L1-L2-L3-N)
220/240	50	1	11	48/0/0/48
240/415	50	3	11	18/14/14/4
230/400	50	3	11	18/15/15/3

BLODGETT OVEN COMPANY

www.blodgett.com • 42 Allen Martin Drive, Essex Junction, VT 05452 • Phone: (802) 658-6600 • Fax: (802) 864-0183