

DESIGNER LINE DISPLAY FREEZER

Model: D1FESNGDHD

Natural Refrigerant R-290 Model

Designer Line

1-Section Extra-Wide Reach-In Freezer with Half Hinged Glass Doors - Shallow Depth

- D1FESNGDHD** - Stainless steel front, aluminum end panels and interior
- D1FESNSAGDHD** - Stainless steel exterior, aluminum interior
- D1FESNSSGDHD** - Stainless steel exterior and interior



Options and Accessories

(upcharge and lead times may apply)

Stainless steel case back	Wine rack
Additional epoxy coated steel shelves	Casters
Chrome or stainless steel shelves	Full door
Rehinging of door (consult factory)	Special electrical req. (consult factory)
Solid doors (consult factory)	Standard depth (consult factory)
	Pass-thru (consult factory)

Consult factory for other model configurations, options and accessories.

Project Name:

Model Specified:

Location:

Item No:

Quantity:

AIA #:

SIS #:

Standard Model Features

REFRIGERATION SYSTEM

Self contained, performance rated refrigeration system (coil in the cabinet zone)

Natural, environmentally safe, high efficiency R-290 refrigerant¹

Automatic, electric condensate evaporator

Expansion valve system

Standard operating temperature is 0 to -5°F and can be adjusted to operate as low as -10°F in a 90°F ambient.

CABINET ARCHITECTURE

3" non-CFC polyurethane foam insulation

Triple-pane, tempered hinged glass doors

Chrome-plated handles

Cam action, lift-off hinges

Self-closing doors

Magnetic snap in door gaskets

Cylinder lock in each door

Heavy duty, epoxy coated steel shelves

Heavy-duty pilaster strips

Adjustable 6" stainless steel legs

MODEL FEATURES

LED interior lighting

Off-cycle defrost

Electronic controller with digital display & hi-low alarm

¹ R-290 refrigerant meets all federal and state regulatory requirements.

Continental
Refrigerator

Toll-Free: 800-523-7138
Phone: 215-244-1400
Fax: 215-244-9579

539 Dunksferry Road
Bensalem, PA 19020
www.continentalrefrigerator.com

APPROVAL:

Model Specifications

DIMENSIONAL DATA

Net Capacity (cubic feet)	18 (510 cu l)
Width, Overall (inches)	28 1/2 (724 mm)
Depth, Overall (inches) (including handle)	29 1/4 (743 mm)
Depth (inches) (less door)	25 7/8 (657 mm)
Depth (inches) (door open 90°)	49 1/2 (1257 mm)
Clear Door Width (inches)	21 7/8 (556 mm)
Clear Door Height (inches)	58 5/8 (1489 mm)
Height, Overall (inches) (including 6" legs)	83 1/4 (2115 mm)
Number of Doors	2
Number of Shelves	4
Shelf Area (square feet)	20.4 (1.9 sq m)

REFRIGERANT DATA

Condensing Unit Size (H.P.)	1/2
Capacity (BTU per hour)*	2470

ELECTRICAL DATA

Voltage (International)	115/60/1 (220/50/1)
Feed Wires (including ground)	3
Total Amps (International)	8.4 (6.0)
Total Defrost Amps (International)	4.4 (3.2)
10 ft. Cord/Plug [attached] (International)	Yes (No)

SHIPPING DATA

Height - Crated (inches)	85 1/2 (2172 mm)
Width - Crated (inches)	31 5/8 (803 mm)
Depth - Crated (inches)	42 (1067 mm)
Volume - Crated (cubic feet)	65 (1841 cu l)
Weight Std - Crated (pounds)	345 (156 kg)
Weight SS - Crated (pounds)	405 (184 kg)



Equipped with one NEMA-5-15P Plug
(varies by country)

Continental
Refrigerator

Toll-Free: 800-523-7138
Phone: 215-244-1400
Fax: 215-244-9579

539 Dunksferry Road
Bensalem, PA 19020
www.continentalrefrigerator.com

Due to our continued efforts in developing innovative products, specifications subject to change without notice.



© Copyright 2021. Continental Refrigerator.
A Division of National Refrigeration & Air Conditioning Products, Inc.

Model Plan Views

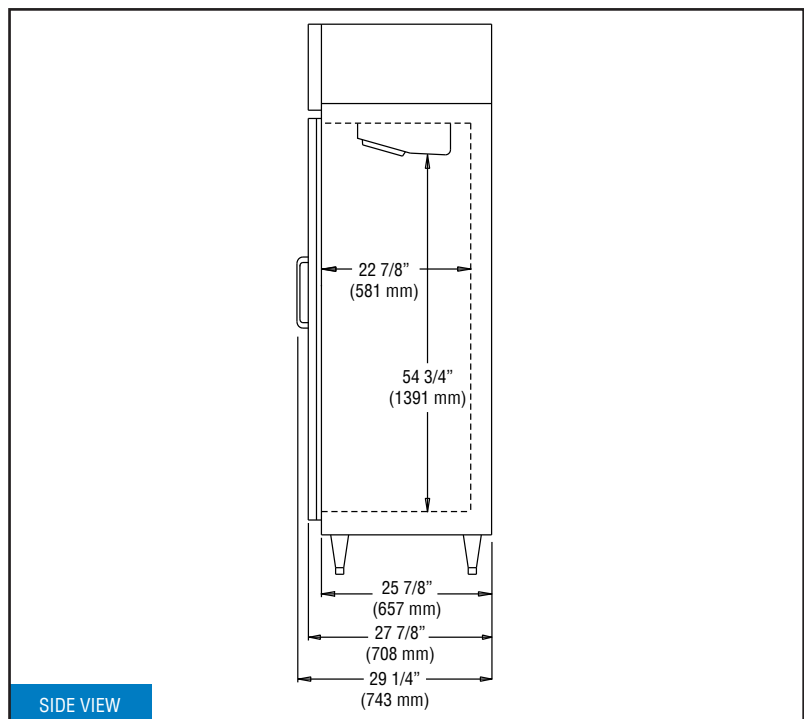
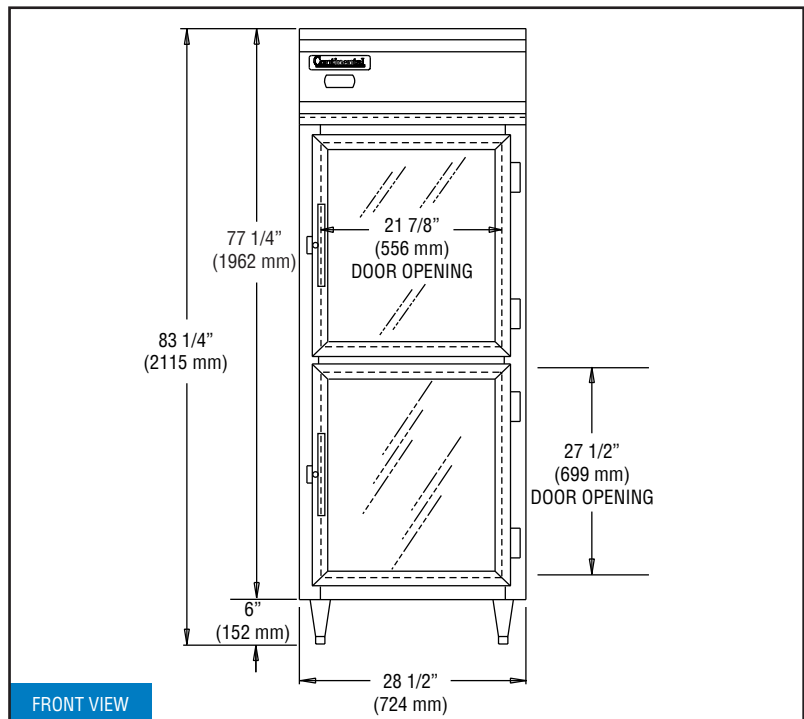

IMPORTANT NOTE: If the cabinet is located directly against a wall and/or under a low ceiling, a minimum clearance of 12" is required on top and 3" on sides and rear.

REVISED: 5/26/2022