



KM-1601SRJZ(3)

STACKABLE CRESCENT CUBER



KM-1601SRJZ(3)
03/15/22
Item # 13663

W x D x H
48" x 27^{3/8}" x 27^{3/8}"

KM Edge
DESIGN

KM-1601SRJZ ★
Remote Air-Cooled 1 Phase

KM-1601SRJZ3
Remote Air-Cooled 3 Phase



Features

- ▶ Individual crescent cube
- ▶ Stainless steel evaporator
- ▶ CycleSaver™ design

- Up to 1671 lbs. of ice production per 24 hours
- Stackable for 3342 lbs. per 24 hours ice production in the same floor space
- Durable stainless steel exterior
- Protected by H-Guard Plus Antimicrobial Agent
- EverCheck™ alert system
- R-404A Refrigerant

Available on Bins:

B-800 **B-1150SS** **B-1500SS** *Top kit may be required.*
B-900 **B-1300SS** **B-1650SS** *See Bin Spec Sheets.*

Warranty:

Valid in United States, Canada, Puerto Rico and U.S. Territories.
Contact factory for warranty in other countries.

Shipping: (LxWxH) 51.75" x 33" X 33.5" Volume: 33.11ft³



Condenser	Model	ICE PRODUCTION		WATER USAGE		ELECTRICAL							
		Air / Water Temp Lbs. per 24 hours 70° / 50°F	90° / 70°F	Potable Gal. per 100 lbs. 90° / 70°F	Condenser Gal. per 100 lbs. 90° / 70°F	kWh Used per 100 lbs. 90° / 70°F	Max. Fuse Sz or HACR Circuit Bkr	Amperage	Voltage	Circuit Wires (including ground)	Heat Rejection BTU/hr.	Refrigerant Charge Amount	Net / Ship Weight (lbs.)
1 Phase Remote	KM-1601SRJZ	1640	1600	17.6	N/A	3.96	20A	15.9A	208-230V/60/1	4*	21,200	15 lbs. 3.4 oz. 22 lbs. 14.8 oz.†	300 / 315
3 Phase Remote	KM-1601SRJZ3	1635	1600	18.0	N/A	4.14	20A	12.8A	208-230V/60/3	4	20,000	15 lbs. 3.4 oz. 22 lbs. 14.8 oz.†	300 / 355

†(with condenser)

*If neutral is not available, transformer kit (HS-5030) is required. Refer to Instruction Manual for installation and electrical requirements.

Power cord not included

KM Edge Cube Dimensions*

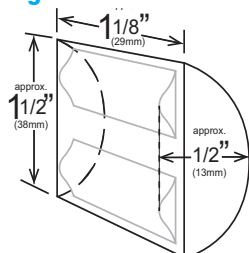

* approximate size in inches, image not to scale

Operating Limits

- Ambient Temp Range 45 - 100°F
- Water Temp Range 45 - 90°F
- Water Pressure 10 - 113 PSIG
- Voltage Range 187 - 253V

Service

- Panels easily removed and all components accessible for service.
- Allow 9" (23 cm) clearance at rear, sides, and top for proper air circulation and ease of maintenance/service.

Plumbing

- Icemaker Water Supply Line: Min. 3/8" Nominal ID Copper Water Tubing or Equivalent
- Icemaker Drain Line: Min. 3/4" Nominal ID Hard Pipe or Equivalent

Line sets for Z models require brazing. Z model head must match Z model remote condenser.

Water Filter

Please refer to water filter spec sheet for recommended configurations.

Hoshizaki reserves the right to change specifications without notice.



KM-1601SRJZ(3)

STACKABLE CRESCENT CUBER

KM-1601SRJZ(3)
03/15/22
Item # 13663

FRONT VIEW

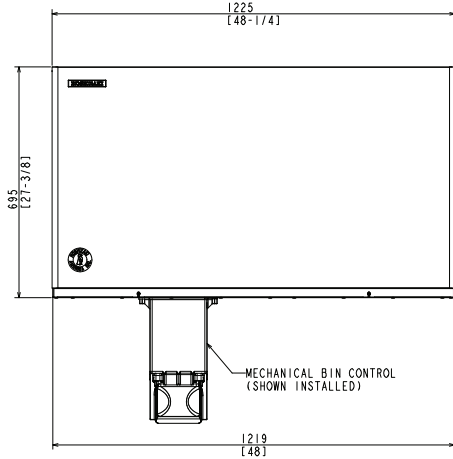

SIDE VIEW

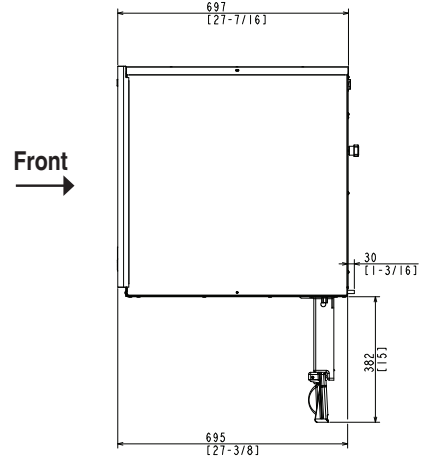

REAR VIEW

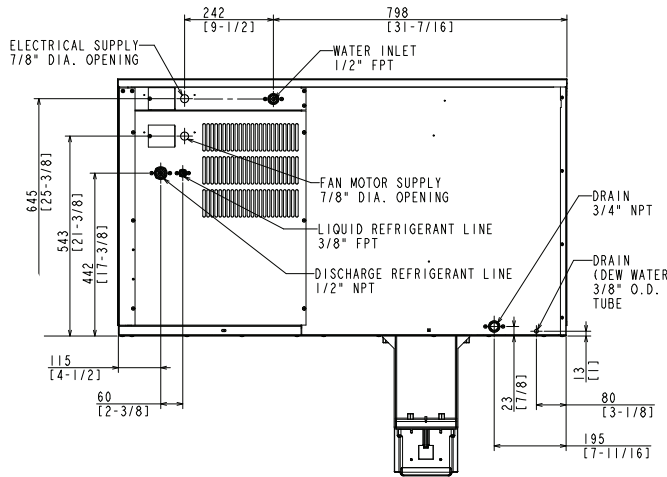

BOTTOM VIEW

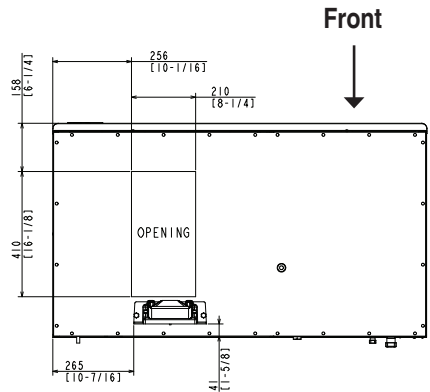

URC-22FZ Remote Condenser (Sold Separately)

(W x D x H) 46^{3/8} X 14^{1/16} X 40^{1/2}
For Use with KM-1601SRJZ(3)

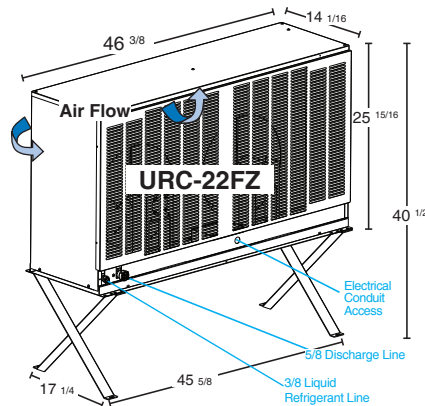

Brazed Line Sets
(Sold Separately)
25' HS-5323
35' HS-5324
55' HS-5325



Voltage supply for the URC Remote Condenser is supplied from the Ice Maker. No additional circuit is required.