



2-Tier Heated Display Case MODEL GM-2P2T



Capacity Accommodates 2 x Full-Size and 2 x Half-Size Pans
No water connection Hold and Display Food without the use of water (no water connection required)
Condensation No condensation build-up on glass
Display Euro-style Curved Glass (side panels).
Wide-Beam Halogen Lighting Enhances product view and stimulates sales
Tempered Mirror Sliding Glass Doors Framed and removable, making display more visible and simplifying the cleaning process
Coated Shatterproof Lighting Halogens
Rubber Gaskets Protects the glass edges from chipping
Heavy Duty Construction Manufactured with high-gauge 304 stainless steel

RESFAB EQUIPMENT INC.

Toll Free: 1-866-359-0808

info@resfab.com | resfab.com

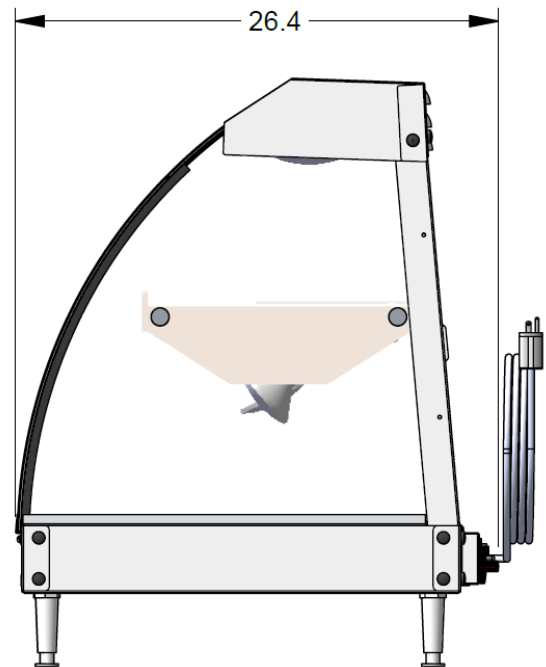
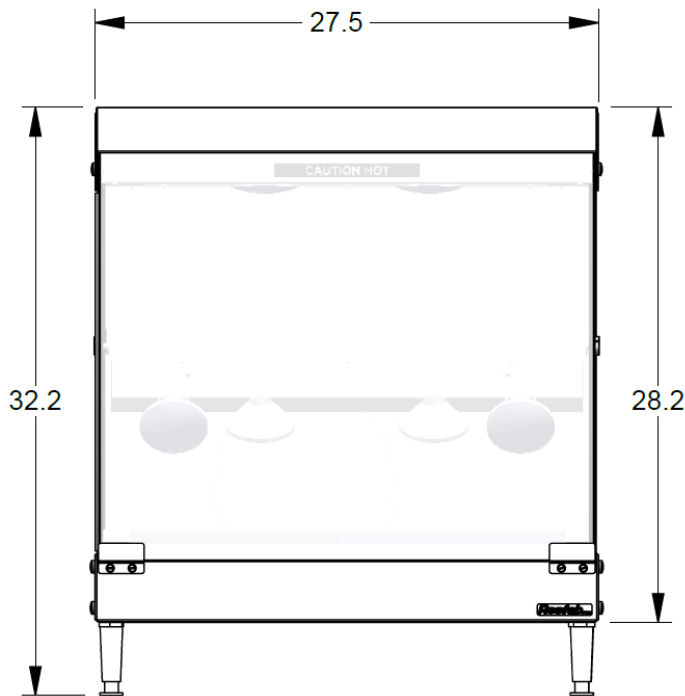

ELECTRICAL

MODEL	GNG-2P2T
VOLTAGE	120 V
AMPERAGE	10.3 A
POWER CORD	10 ft
LIGHT BULBS (HALOGEN)	6 X 50W
PLUG	NEMA 5-15P

DIMENSIONS

WEIGHT	120 lbs
WEIGHT – CRATED	185 lbs
CRATE DIMENSIONS	W 34" x H 40" x D 30"

INSTALLATION REQUIREMENTS

- DISPLAY CASE MUST BE INSTALLED LEVEL
- USE THE 4 LEGS OR SEAL THE CASE TO THE COUNTER WITH NSF FOOD GRADE CAULKING



RESFAB EQUIPMENT INC.

Toll Free: 1-866-359-0808

info@resfab.com | resfab.com