

# BASE MODEL SANDWICH UNIT

## Model: RA43N9M-D

Natural Refrigerant R-290 Model

### 43" Mighty Top Sandwich Unit Refrigerator with Drawers - 9 Pans

Heavy gauge #300 series stainless steel top, stainless steel front and end panels, galvanized steel rear and grills and aluminum interior.



## Options and Accessories

(upcharge and lead times may apply)

|   |  |
|---|--|
| Stainless steel interior                                  | Composite cutting board                  |
| Stainless steel back                                      | Rear mounted cutting board               |
| Overshelves (single or double)                            | Condensing unit left (standard on right) |
| Flat insulated night cover                                | Adjustable legs                          |
| Door & drawer locks                                       | Front breathing                          |
| Vision panel lid  |  |
| Drawer in lieu of door section above the condensing unit* |  |

Consult factory for other model configurations, options and accessories.

\*Drawer section above condensing unit holds (1) 12 x 20 x 6 pan.

Project Name:

Model Specified:

Location:

Item No:

Quantity:

AIA #:

SIS #:

## Standard Model Features

### REFRIGERATION SYSTEM

Performance rated refrigeration system

Natural, environmentally safe, high efficiency R-290 refrigerant<sup>1</sup>

Unique forced air design utilizes fans (approx. every 12") across the entire back of unit for even distribution of cold

Automatic, hot gas condensate evaporator

Non-corrosive, plasticized fin evaporator coil

Easily serviceable, slide out condensing unit

Expansion valve system

### CABINET ARCHITECTURE

2" non-CFC polyurethane foam insulation

Smooth, polished chrome door & drawer handles

Spring loaded, self closing door over condensing unit

Magnetic snap in Santoprene™ door gaskets

Stainless steel roll out drawers

10" deep, full length nylon cutting board

Insulated lid

5" casters

### MODEL FEATURES

Refrigerated section with door above the condensing unit

(9) 1/2 size recessed pans, 4" deep

Electronic control, off-cycle defrost

Field rehingeable door over condensing unit

<sup>1</sup> R-290 refrigerant meets all federal and state regulatory requirements.

**NOTE:** Models come standard with a door above the condensing unit. A drawer above the condensing unit is an option.

**Continental**<sup>®</sup>  
Refrigerator

Toll-Free: 800-523-7138  
Phone: 215-244-1400  
Fax: 215-244-9579

539 Dunksferry Road  
Bensalem, PA 19020  
www.continentalrefrigerator.com

APPROVAL:

# Model Specifications

## DIMENSIONAL DATA

|  |                 |
|--|-----------------|
| Net Capacity (cubic feet)                                | 12 (340 cu l)   |
| 1/6 Size Pans (4" deep)                                  | 9               |
| Width, Overall (inches)                                  | 43 (1092 mm)    |
| Depth, Overall (inches)<br>(including handles & bumpers) | 37 (940 mm)     |
| Depth, Cutting Board (inches)                            | 10 (254 mm)     |
| Height, Overall (inches)<br>(including 5" casters)       | 42 (1067 mm)    |
| Number of Drawers  | 2               |
| Number of Half Doors                                     | 1               |
| Interior Depth (inches)<br>(above condenser)             | 30 (762 mm)     |
| Interior Height (inches)<br>(above condenser)            | 12 1/2 (318 mm) |
| Interior Width (inches)<br>(above condenser)             | 17 (432 mm)     |

## REFRIGERANT DATA

|                             |      |
|-----------------------------|------|
| Condensing Unit Size (H.P.) | 1/4+ |
| Capacity (BTU per hour)*    | 2000 |

## ELECTRICAL DATA

|  |                     |
|--|---------------------|
| Voltage (International)                        | 115/60/1 (220/50/1) |
| Total Amps (International)                     | 4.5 (3.4)           |
| 10 ft. Cord/Plug [attached]<br>(International) | Yes<br>(No)         |

## SHIPPING DATA

|                          |                  |
|--------------------------|------------------|
| Weight (pounds)          | 350 (159 kg)     |
| Height - Crated (inches) | 43 3/4 (1111 mm) |
| Width - Crated (inches)  | 45 (1143 mm)     |
| Depth - Crated (inches)  | 47 (1194 mm)     |

## DRAWER PAN CONFIGURATIONS

**Two Tier:** (1) 12 x 20 x 6 pan & (3) 1/6 x 6 pans (top)  
(2) 12 x 20 x 6 pans (bottom). Three tier not available.

\* Rating @ +25°F evaporator, 90°F ambient  
Figures in parentheses reflect metric equivalents rounded to the nearest whole unit.



Equipped with one NEMA-5-15P Plug  
(varies by country)

**Continental**  
Refrigerator

Toll-Free: 800-523-7138  
Phone: 215-244-1400  
Fax: 215-244-9579

539 Dunksferry Road  
Bensalem, PA 19020  
[www.continentalrefrigerator.com](http://www.continentalrefrigerator.com)

Due to our continued efforts in developing innovative products, specifications subject to change without notice.



© Copyright 2021. Continental Refrigerator.  
A Division of National Refrigeration & Air Conditioning Products, Inc.

# Model Plan Views

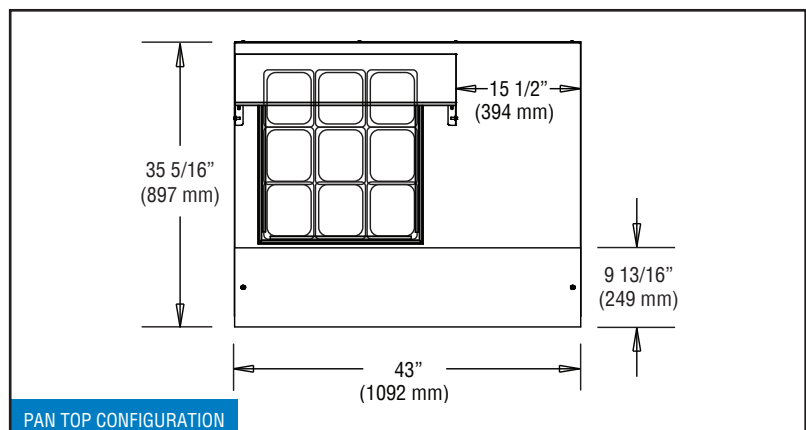
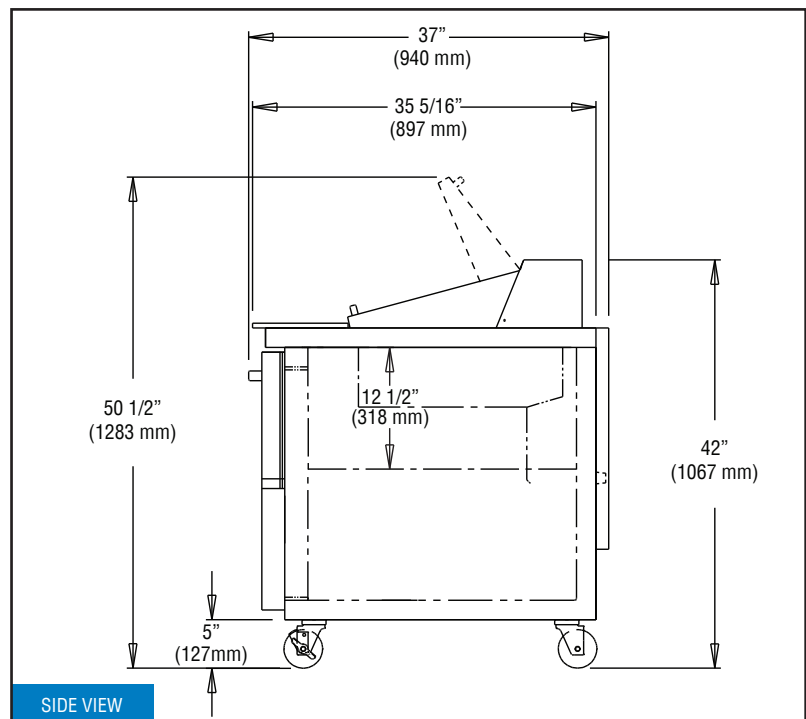
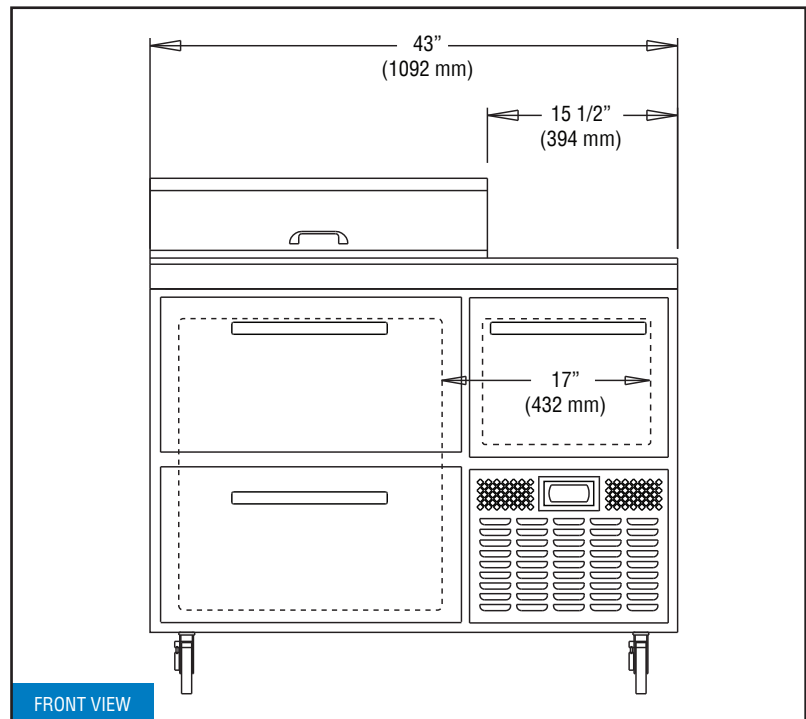

REVISED: 7/21/2022