



FD-650MRJZ-C

Modular Cubelet Ice Machine
Slim-Line Dispenser Series

FD-650MRJZ-C
09/17/21
Item # 13618

W x D x H
22" x 24" x 26"

FD-650MRJZ-C*
Remote Air-Cooled
Shown on optional
Lancer IBD Bold 30i



Item #: _____
Project: _____
Qty: _____
AIA#: _____

Features

- ▶ Durable stainless steel exterior
- ▶ Advanced CleanCycle24™ design 
- ▶ Stainless steel auger with greaseless bearing

- Up to 588 lbs. of ice production per 24 hours
- 2 second flush cycle every hour
- Flush cycle removes sediment for cleaner ice
- Infrared bin control for easy cleaning and reliability
- Protected by H-GUARD Plus Antimicrobial Agent 
- R-404A Refrigerant

Available on Bins:

B-250SF B-500SF B-700S B-800SF B-900SF

Top kit may be required; See Bin Spec Sheets.

Warranty:

3 Year Parts & Labor on entire machine. 5 Year Parts on Compressor; air-cooled condenser coil. Valid in United States, Canada, Puerto Rico and U.S. Territories. Contact factory for warranty in other countries.

Shipping: (LxWxH) 28.5" x 26.75" x 32" Volume: 14.12ft³

Condenser	Model	ICE PRODUCTION		WATER USAGE		ELECTRICAL					Refrigerant Charge Amount	Net / Ship Weight (lbs.)	
		Air / Water Temp Lbs. per 24 hours 70°/ 50°F 90°/ 70°F		Potable Gal. per 100 lbs. 90°/ 70°F	Condenser Gal. per 100 lbs. 90°/ 70°F	kWh Used per 100 lbs. 90°/ 70°F	Max. Fuse Sz or HACR Circuit Bkr	Amperage	Voltage	Circuit Wires (including ground)			Heat Rejection BTU/hr.
Remote	FD-650MRJZ-C	588	470	12.0	N/A	4.95	20A	10.9A	115V/60/1	3	5,900	2 lbs. 3.3 oz. 4 lb. 1 oz.*	176 / 205

* (with condenser)

Cube Dimensions*

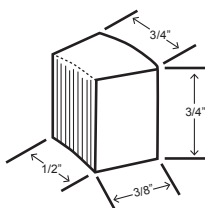

* approximate size in inches, image not to scale

Operating Limits

- Ambient Temp Range 45 - 100°F
- Water Temp Range 45 - 90°F
- Water Pressure 10 - 113 PSIG
- Voltage Range 104-127V

Service

- Panels easily removed and all components accessible for service.
- Allow 24" (61 cm) clearance at top for removal of auger and 6" (15 cm) clearance at rear and sides for proper air circulation and ease of maintenance/service.

Plumbing

- Icemaker Water Supply Line: Minimum 1/4" Nominal ID Copper Water Tubing or Equivalent
- Icemaker Drain Line: Minimum 3/4" Nominal ID Hard Pipe or Equivalent

Line Sets

- Line sizes for lengths up to 66': 1/4" LIQ and 3/8" DIS
- Line sizes for lengths greater than 66' to a maximum of 100': 3/8" LIQ and 1/2" DIS plus charge adjustment - add 16.5 oz. (468 g) of refrigerant to compensate for larger diameter line sizes and 0.4 oz. (11 g) for each foot over 66'.

Water Filter

Please refer to water filter specification sheet for recommendations.

Hoshizaki reserves the right to change specifications without notice.



FD-650MRJZ-C

Modular Cubelet Ice Machine
Slim-Line Dispenser Series

FD-650MRJZ-C
09/17/21
Item # 13618

FRONT VIEW

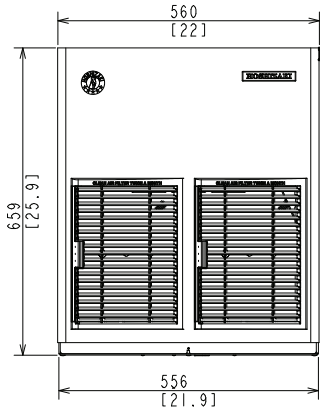

SIDE VIEW

Front
→

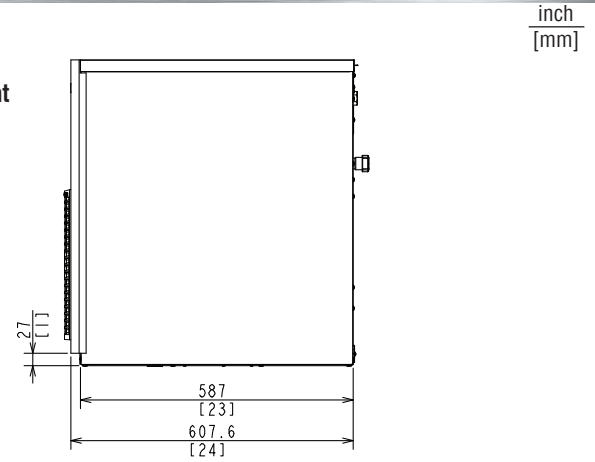

REAR VIEW

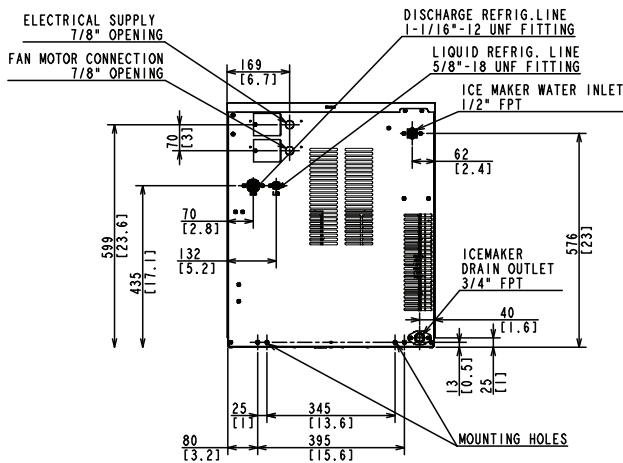

BOTTOM VIEW

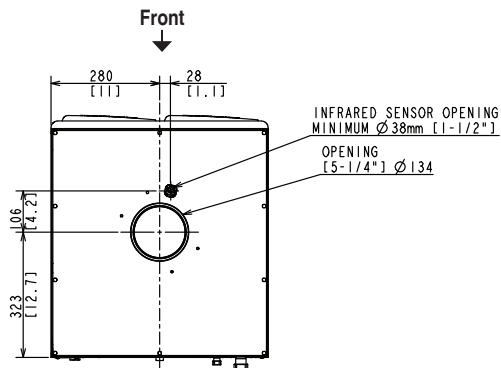

URC-5FZ Remote Condenser (Sold Separately)
(W x D x H) 21^{13/16} x 14^{1/16} x 32^{13/16}
For Use with FD-650MRJZ-C



Pre-Charged Tubing Kits (Sold Separately)
20' R404-2046-2
35' R404-3546-2

Voltage supply for the URC Remote Condenser is supplied from the Ice Maker. No additional circuit is required.

