

Rotisol



 BASKET RÔTISSERIE

Rôti-Roaster

FBP8.720

DESIGN

- High performance, elegant and modern rotisserie with interior lighting to accentuate your roasting meats and vegetables
- All stainless steel body
- Optional: Double-convex, anti-burn glazing with illuminated "ROTISSERIE" sign

CULINARY ADVANTAGES

- Rapid roasting while still retaining rotisserie quality
- Display and programming of cooking time and temperature
- 6 cooking programs with alert at end of cycle - products can then be maintained at 145° F
- Latest range of heating elements
- 5 chicken baskets engineered for easy unloading
- Also suitable for other poultry, meats and vegetables

SAFETY

- K.Glass door reduces heat loss, hence quicker cooking times, and prevents burns
- Automatic cooling of the heating turbine at the end of the cooking cycle
- Drip pan with plug to collect grease for ensured hygiene and safety
- New generation of rotisserie with very low energy consumption, fully insulated model



Option: double convex anti-burn glazing



CLEANING

- Disassembly of all cooking accessories for simple cleaning
- Removable inside panel and grease pan for easy cleaning
- Protection of the interior lighting by ceramic glass for easy surface cleaning

ACCESSORIES



Top view

Front view

43 1/8"
1095

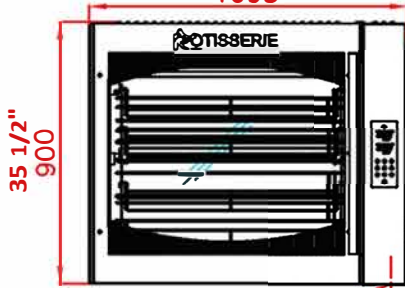

Electric power

Side view

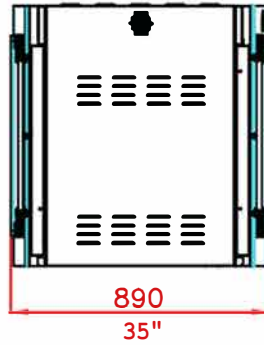

ROTI-ROASTER

98 1/2"
2500

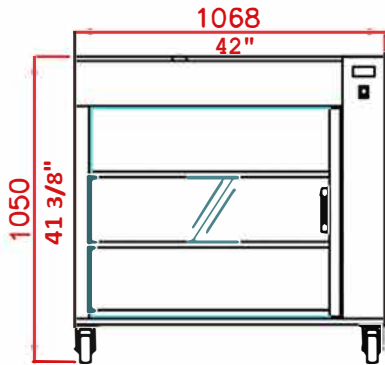
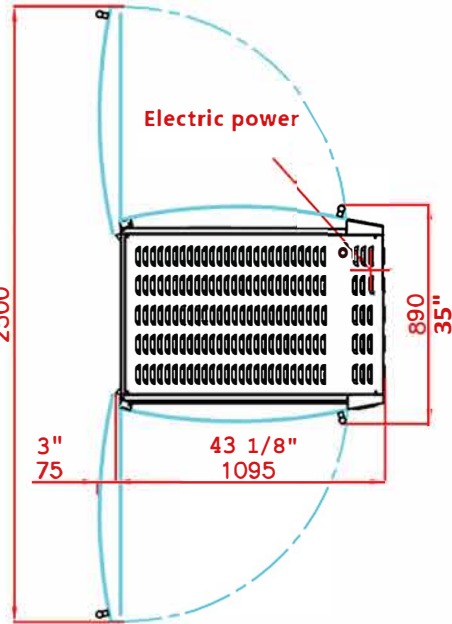

Heated
base
cabinet
(Option)

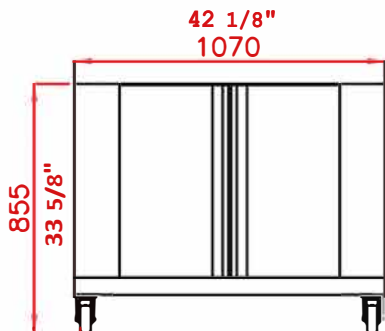
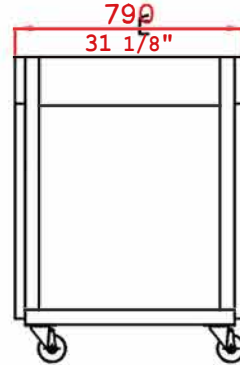

Supporting
cupboard
(Option)

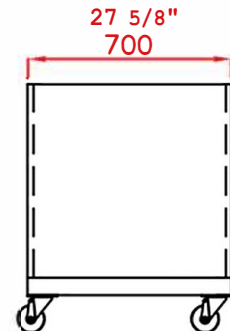

Shown with optional Band with illuminated sign

STANDARD FIXTURES

- STD FINISH : Stainless Steel
- 8 Chicken Baskets
- 2 tempered glass doors (K.Glass)
- Drip pan
- Removable protective inside side panels

SPECIFICATIONS

Electricity	8.4 KW / 3-phase / 208-240v / 60 Hz
Capacity	32-40 CHICKENS
Warranty	1 year
Venting	A hood must be installed to conform to all local codes
Minimum clearance	2 1/2" at the right, left and rear

