



MODEL 961/966 Deck Oven



Project _____

Item No. _____

Quantity _____

Ovens consist of basic sections and are a complete and separate unit capable of operating alone or in combination.

All data is shown per oven section, unless otherwise indicated.

Refer to operator manual specification chart for listed model name.

961/966 - Double

EXTERIOR CONSTRUCTION

- Full angle iron frame
- Stainless steel front, top, sides and back
- Counterbalanced doors with concealed hinges
- Heavy chrome plated tubular steel door handle
- 7" (178mm) stainless steel legs are adjustable for leveling
- Burner doors open easily for ignition, cleaning or adjustment, without removal of any fastenings
- Vitreous fiber insulation at top, back, sides, bottom and doors.

INTERIOR CONSTRUCTION

- (1 - 961) 42" x 32" x 7" (1067mm x 813mm x 178mm)
- (1 - 966) 42" x 32" x 16-1/4" (1067mm x 813mm x 413mm) oven compartment interior
- Aluminized steel baking compartment liner
- Aluminized steel combustion chamber
- Steel deck supported by an angle iron frame
- 12 gauge (3.02mm) press-formed, reinforced and flanged aluminized steel deck

OPERATION

- Free-floating, easily removable duplex-tube burner
- Removable fixed orifices on main and pilot burner
- Main gas valve, temperature control valve and safety pilot valve fully within section body and are accessible through a covered and ventilated compartment in front.
- Air mixers with adjustable air shutters and locking device
- Liquid pressure thermostat with temperature control range of 200°F (93°C) to 500°F (288°C)

STANDARD FEATURES

- Fahrenheit dial 200°F to 500°F
- Vent kit
- Large crown angle trim
- Double connector for stacking
- Steel oven deck
- Two year parts and one year labor warranty
- Five year limited oven door warranty*

* For all international markets, contact your local distributor.

OPTIONS AND ACCESSORIES

(AT ADDITIONAL CHARGE)

- Flexible gas hose with quick disconnect and restraining device:
 - 36" (914 mm)
 - 48" (1219mm)
- QHT Rokite deck 1-1/2" (38.1mm) thick pizza type deck
- Steam jets
- FDTH 300° to 650° temperature thermostat

OPTIONS AND ACCESSORIES

(AT NO ADDITIONAL CHARGE)

- Centigrade dial, 100°C to 300°C



Intertek



0539

BLODGETT OVEN COMPANY

www.blodgett.com

42 Allen Martin Drive, Essex Junction, VT 05452 • Phone: (802) 658-6600 • Fax: (802) 864-0183



MODEL 961/966

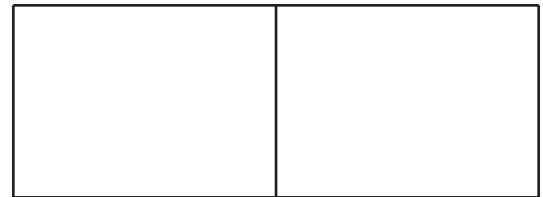

APPROVAL/STAMP

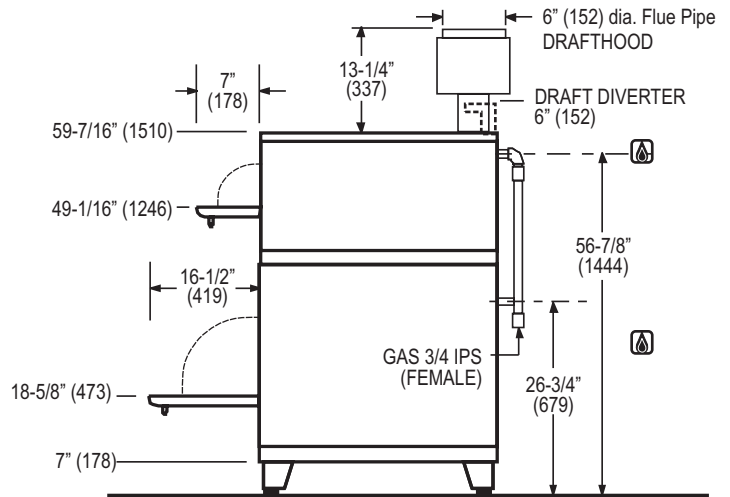
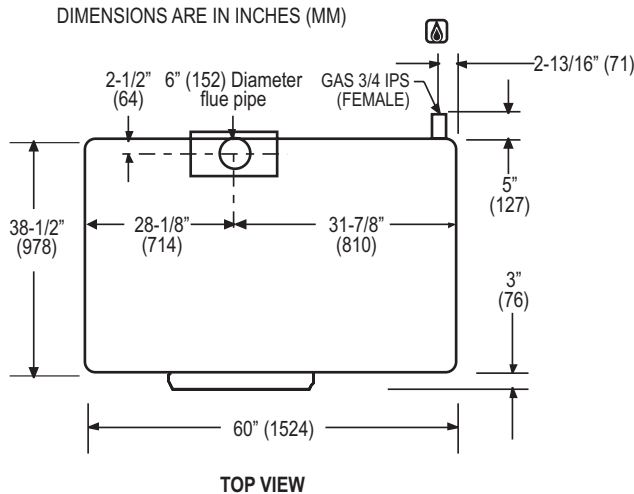

SHORT FORM SPECIFICATIONS

Provide Blodgett combination deck oven, model 961/966. Each unit shall be a combination of two independent ovens with single, manifolded gas connections and flues. Construction shall be welded stainless steel top, front, back and sides, and shall be fully insulated on all sides. Ovens shall be supported by 7" high formed adjustable legs. Doors shall be counter-balanced (no springs) with concealed hinges and chrome plated tubular steel handles. Separate burner door provided for ignition, cleaning and adjustment. The upper section baking compartment shall be 42" W x 7" H x 32" D; the lower section baking compartment shall be 42" W x 16-1/4" H x 32" D. Both shall be lined with aluminized steel, and decks shall be of 11 gauge press-formed, reinforced and flanged steel. Each section shall be gas heated by a free-floating, easily removable, duplex-type burner controlled by a liquid pressure thermostat with range of 200°F to 500°F. Provide with two year parts and one year labor warranty. Provide with options and accessories as indicated.

DIMENSIONS:

Number of sections:	2
Number of controls:	2
Number of compartments:	2
Size of compartment (1):	42" (1067mm) W x 7" (178mm) H x 32" (813mm) D
Size of compartment (1):	42" (1067mm) W x 16-1/4" (413mm) H x 32" (813mm) D
Area of each compartment:	9.34 sq. ft. (0.87m ²)
Total area of oven:	18.68sq. ft. (1.74m ²)
Clearance below oven:	6" (152mm)
Floor space:	60" (1524mm) wide x 40" (1016mm) deep
Product clearance:	6" from combustible and non-combustible construction

PAN CAPACITIES:

10" (254mm) pie tins:	24
18" x 26" (457mm x 660mm) bun pans:	4
9-1/2" x 5" (241mm x 127mm) bread pans:	48
9" x 7" (228mm x 178mm) roll pans:	32
19" x 4" (483mm x 102mm) pullman pans:	28
13" x 16-1/2" (330mm x 419mm) cup tins:	18
20" x 28" (508mm x 711mm) roast pans:	4
No. 200 pans (324mm x 527mm):	8
Bean pots #1:	70
#3:	40
#6:	24
25 lb. (11kg) Turkeys:	5

GAS SUPPLY:

3/4" IPS connection at rear of oven
 Manifold Pressure:
 • Natural – 5" W.C. • Propane – 10" W.C.
 Inlet Pressure:
 • Natural – 7.0" W.C. min. – 10.5" W.C. max.
 • Propane – 11.0" W.C. min. – 13.0" W.C. max.

MAXIMUM INPUT:

961 only	37,000 BTU/hr
966 only	50,000 BTU/hr
Double (961/966)	87,000 BTU/hr

MINIMUM ENTRY CLEARANCE:

Uncrated	32-1/2" (826mm)
Crated	37" (940mm)

SHIPPING INFORMATION:

Approx. Weight:

961	540 lbs. (245kg)
966	630 lbs. (286kg)
961/966	1170 lbs. (531kg)

Crate sizes:

65" (1651mm) x 27" (686mm) x 46.5" (1181mm)
65" (1651mm) x 37" (940mm) x 46.5" (1181mm)

NOTE: The company reserves the right to make substitutions of components without prior notice

BLODGETT OVEN COMPANY

www.blodgett.com

42 Allen Martin Drive, Essex Junction, VT 05452 • Phone: (802) 658-6600 • Fax: (802) 864-0183