

Project:



Scan for more info!

Owners manual
Quick install
Quick sizing
Install layout
Parts list

CP-JR-CT1-SWF-K

Faucet handle, countertop mount



Low volume chilled water on tap

- Perfect for office, hotel suites, wineries & residential
- Compact size for the least intrusive counter space usage
- Designed for dispensing individual servings in a beverage cup
- Integrated CR-12FC filter system

Specifications

- 40, 8oz drinks per hour @ 40°
- Self-contained refrigeration system
- Compressor: 1/9 H.P.
- Operating temperature range: 40° - 100°
- Electrical: 120v - 3 Amps
- Water bath: 1.5 Gallon
- Ice bank: 3 lbs
- Weight: 60 lbs
- Clearance: 8"
- 10.625"W x 21.25"D x 17"H
- CR-LBS10JG - Leak block sensor
- All fittings needed for installation

* For CP-JR units using reverse osmosis water, add -RO to the end of the model number and call for pricing.

* All other CP-JR chillers are compatible with reverse osmosis water as is

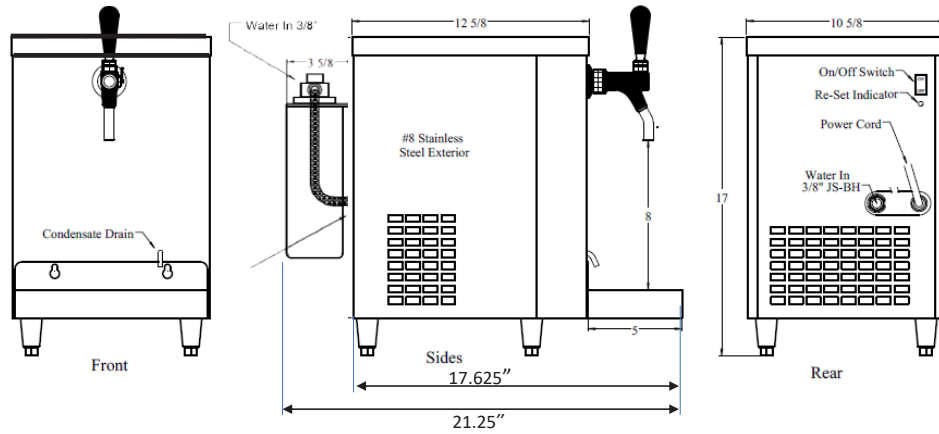

- Air intake on left side
- Allow for 6" rear & side clearance around unit for air flow
- 2.5" legs
- Pre-mounted water filter system 2FC quick change cartridge
- Filter rated at 1.5 gpm, 6,000 Gallons
- 1/2 micron particulate reduction, taste, odor, color & contaminant reduction
- 3/8" water connection
- 9' electrical cord NEMA 5-15 plug
- Condensate drain into drip pan

Complete installation kit is included with purchase of unit

The unit comes standard with a filter system built on and a water pressure reducer valve installed. Installation kit comes complete with a leak block sensor, hose and angle stop fittings.



+



=



Accessories:

- **2FC replacement filter**
Replacement water filter
Compact fibredyne cartridge for CP-JR models



- **CR-SDL-SSX1**
Universal sanitary lever assembly for use on countertops, custome towers, and are able to be retrofit to CBR towers

