

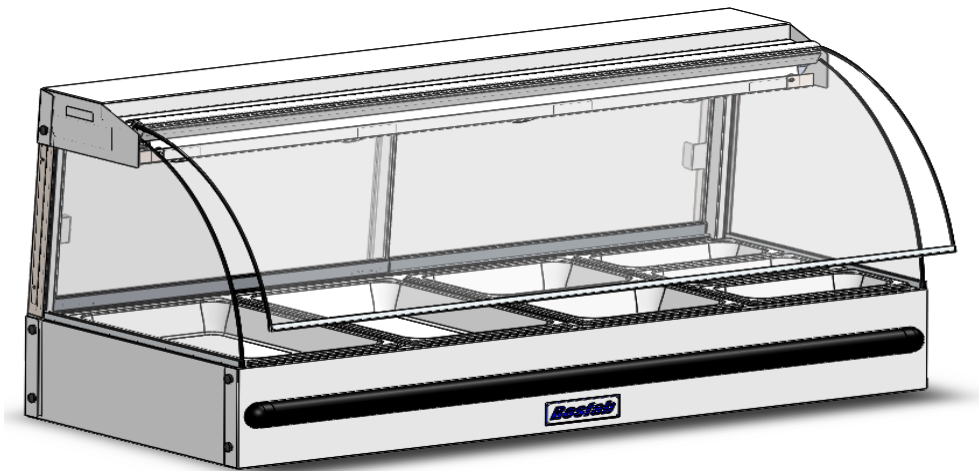

HEATED DISPLAY CASE MODELS GM-3P, GM-4P, GM-5P



Air-insulated wall between wells



Digital temperature controller
(one per well)

Independently Controlled Wells Maximizes the Quality of each food item
L.E.D. Digital Display Temperature Controllers One for each well
Each well has an air-insulated wall To avoid heat transfer to other wells
Large Capacity Each well can accommodate a 4" Full-Size Pan or any configuration of smaller pans
No water connection Hold and Display Food without the use of water no water connection required
Condensation No condensation build-up on glass
Display Euro-style Curved Glass opens for easy cleaning
Low Profile Display Makes it easy to serve and see customers at the same time
Wide-Beam Halogen Lighting Enhances product view and stimulates sales
Tempered Mirror Sliding Glass Doors Framed and removable for cleaning, make the product display more attractive and simplify
Coated Shatterproof Lighting Halogens
Rubber Gaskets Protect the glass edges from chipping
Protective Bumper Front is equipped with a Protective Bumper
Heavy Duty Construction Manufactured with high-gauge 304 stainless steel
Adjustable Legs Comes equipped with 4 adjustable legs (4")
Work Table Optional Stainless Steel work table available for operator side.

SPECIFICATIONS

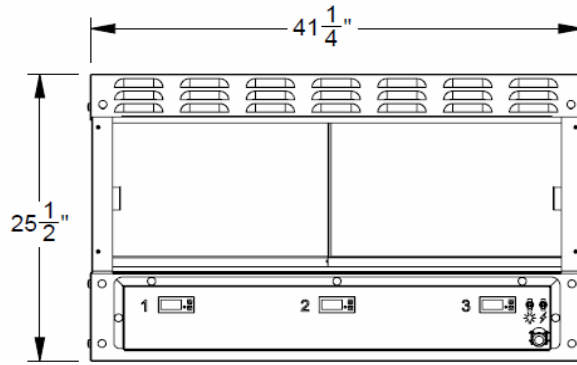
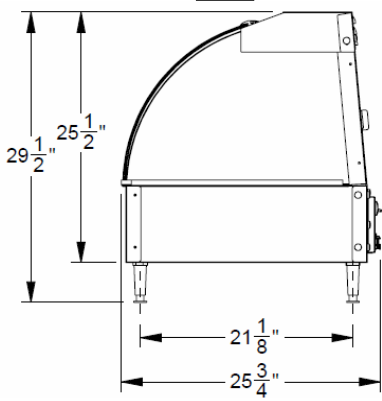

GM-3P

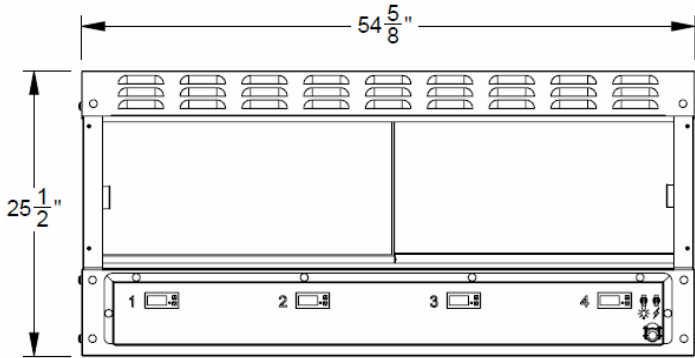
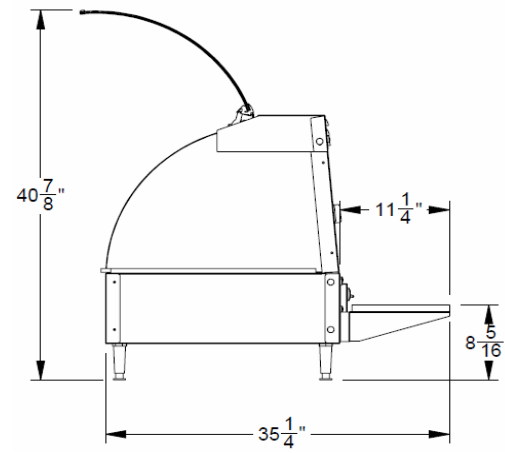

GM-4P

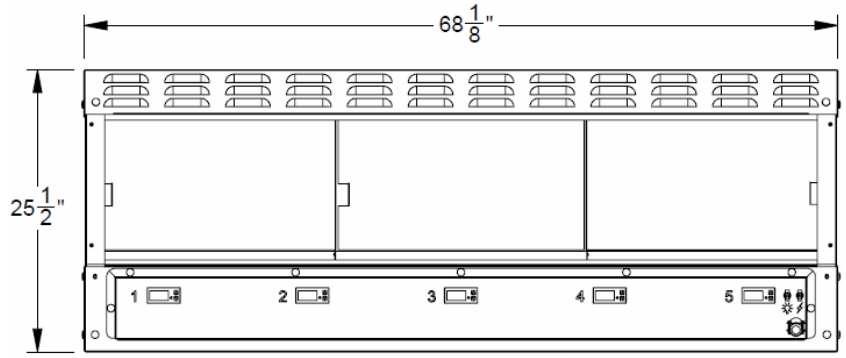

GM-5P

ELECTRICAL

MODEL	GM-3P		GM-4P		GM-5P	
VOLTAGE	120/208	120/240	120/208	120/240	120/208	120/240
HEATER WATT	900	900	1200	1200	1500	1500
LIGHTING WATT	450	450	600	600	750	750
AMPERAGE	9	8	12	11	15	14

DIMENSIONS WITHOUT LEGS

MODEL	LENGTH	DEPTH	HEIGHT
GM-3P	41 5/16	25 3/4	25 1/2
GM-4P	54 5/8	25 3/4	25 1/2
GM-5P	68 1/8	25 3/4	25 1/2

INSTALLATION

INSTALLATION REQUIREMENT:
 DISPLAY CASE MUST BE INSTALLED LEVEL. USE
 THE 4 LEGS OR SEAL THE CASE TO COUNTER
 WITH NSF CAULKING

CAPACITY	
MODEL	FULL PAN
GM-3P	3
GM-4P	4
GM-5P	5



ANSI/NSF 4

Toll Free: 1-866-359-0808

info@resfab.com

WWW.RESFAB.COM