



INFRARED BROILERS (FREE STANDING)



E-170 (Single Deck)



E-171 (Single Deck with Warming Oven)



E-270 (Double Deck)

- E-170
- E-171
- E-270

Standard Features

- Stainless steel front, sides and back panel
- 12 kW ceramic infrared heating elements - per rack
- 30 minute preheat with no waiting between loads
- Rugged grid height adjustment mechanism with five positions
- Roll-out broiling area is 24-1/2" wide and 27-1/2" deep, with a reduced heat holding area in the front 3"
- Fully insulated lining and burner boxes
- Removable grids with a round pattern for branding
- 6" adjustable stainless steel legs
- Model E-171 has a warming oven that is heated by 3,000 watt heating element.
- (1) year limited parts and labor warranty (reference <http://www.southbendnc.com/service.html> for limited warranty details)

OPTIONS & ACCESSORIES AT ADDITIONAL COST

- Casters - front two casters lock
- Cable restraint kit (to restrict movement when on casters)

STANDARD CONSTRUCTION SPECIFICATIONS

Exterior Finish: All exterior panels are 430 stainless steel #3 polish. **Legs:** Stainless steel 6" adjustable legs standard.

Interior Finish: 430 stainless steel interior **Warming Oven:** 25" wide and 25" deep oven, located on top of broiler, is heated by 3,000 watt electric heating element.

Broiler: 6 kW per deck ceramic infrared burners with separate controls. Wired 208/240V, 60 cycle in single or three phase.

Broiler Grid: Roll-out broiler grid is 24-1/2" wide and 28" deep (rolls out to 17-1/4"), with five height positions. The front 3" receive less heat so can be used as a holding area.



Approval Notes: _____

Dimensions shown in inches and (millimeters)

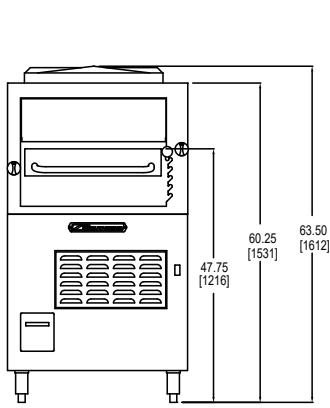
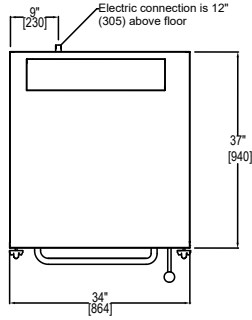

Model E-170

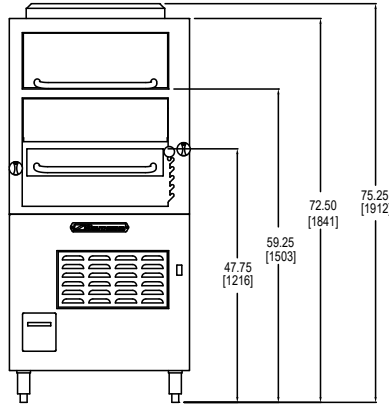

Model E-171

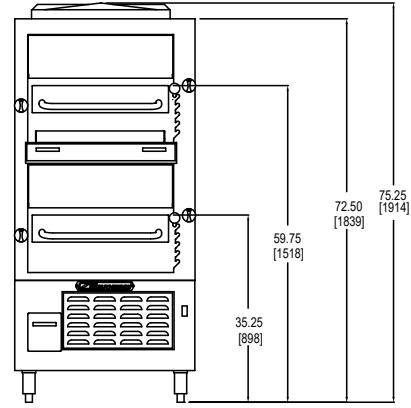

Model E-270

DIMENSIONS & WEIGHT

SHIPPING CRATE

MODEL	WIDTH	HEIGHT	DEPTH	VOLUME	WEIGHT
E-170	45.5" (1156)	83" (2108)	55" (1397)	120.2 cu ft (3.40 cu m)	618 lbs (280.1 kg)
E-171	45.5" (1156)	83" (2108)	55" (1397)	120.2 cu ft (3.40 cu m)	693 lbs (314.3 kg)
E-270	45.5" (1156)	83" (2108)	55" (1397)	120.2 cu ft (3.40 cu m)	932 lbs (422.7 kg)

Dimensions shown in inches and (millimeters)

UTILITY INFORMATION

ELECTRICITY: Electric models must install power cord for 208/240V, 60 Hz single or three-phase. Appropriate circuit protection is the responsibility of the owner.

Model	ELECTRICAL DATA				
	Voltage	1 Phase	3 Phase		
			X	Y	Z
E-170 12 kW Heating Elements and Controls	208V, 60 Hz	58	34	34	34
	240V, 60 Hz	50	29	29	29
E-171 12 kW Heating Elements and Controls 3 kW Warming Oven	208V, 60 Hz	73	42	34	42
	240V, 60 Hz	63	36	29	36
E-270 24 kW Heating Elements and Controls	208V, 60 Hz	116	67	67	67
	240V, 60 Hz	100	58	58	58

MISCELLANEOUS

- Minimum clearance from noncombustible construction is zero. Minimum clearance from combustible construction is 6" on sides and rear.
- Install under vented hood.
- Check local codes for fire and sanitary regulations.

NOTICE:

Southbend has a policy of continuous product research and improvement. We reserve the right to change specifications and product design without notice. Such revisions do not entitle the buyer to corresponding changes, improvements, additions or replacements for previously purchased equipment.

**INTENDED FOR COMMERCIAL USE ONLY.
NOT FOR HOUSEHOLD USE.**

