

DESIGN

Rotisol's most popular line, the GrandFlame combines the drama of visible flames and the beauty of elegant finishes with the highest degree of functionality.

A wide array of spits allow the chef to cook anything that can be roasted: whole or split chickens, lamb, beef roasts and steaks, cuts of pork, porchetta, fish, vegetables, even fruit.

The optional Vertical Spit System with its choice of eight hanging accessories expands the menu possibilities even more and adds additional visual appeal.

FEATURES

- Energy efficient
- Tempered K-glass doors
- Independent motor for each spit
- Equipped with bottom drip tray with built-in drainage
- Rotisol patented burners
- Powerful halogen lamps
- Delivered with 3 prongless spits (CUI975)
- Illuminated "RÔTISSERIE" sign for enamel model only
- Base on casters with brakes



GF975-2G-LUX

Black porcelain enamel and brass
shown with optional roof & base

TECHNICAL DETAILS

Overview of some of the standard features.



Stainless steel burner with removable air filter (Rotisol patent)

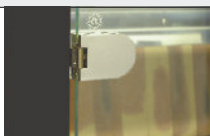

Robust hinges designed for heavy use, with integrated locking in open and closed positions

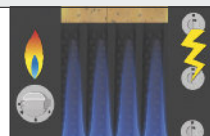

Gas safety ! separation of the gas and electric chambers avoids any risks of explosion

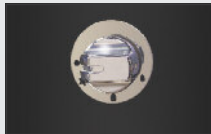

Gas and electric switches, in chromed or brass-colored metal

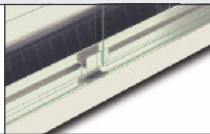

Anti-scald K-glass reduces external thermal radiation (energy saving). Glass overlaps drip pan to keep splatters inside (anti-slip protection).



Removable inside side-panels doubles protection from grease seeping into motors and other sensitive parts

ACCESSORIES

A variety of accessories are available. See video of available accessories and of vertical spit system online.

| | | | | | |
|--|---|---------------------------------|--|--|---|
| CUI975 Anti-cutting prongless V-spit |  | BP975 Chicken spit |  | BRC975 Rectangular basket spit |  |
| BS975 Spit for ham / turkey |  | BRRO975 Roast-clamp spit |  | BA975 Lamb/suckling-pig spit |  |
| BCR975 Spatchcock chicken basket |  | DEC Spit mover |  | BPOR975 Porchetta spit |  |

Front view
Rotisserie with roof

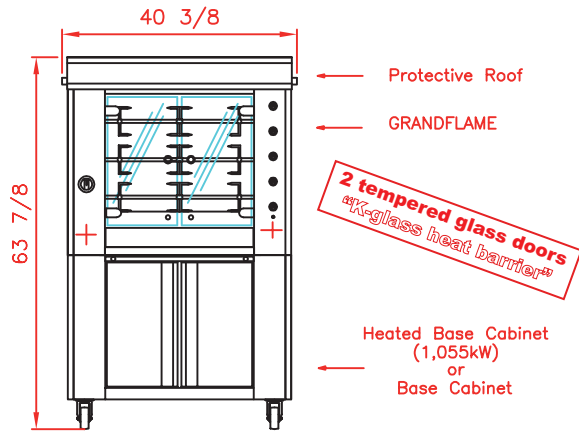

Top view
Rotisserie with roof

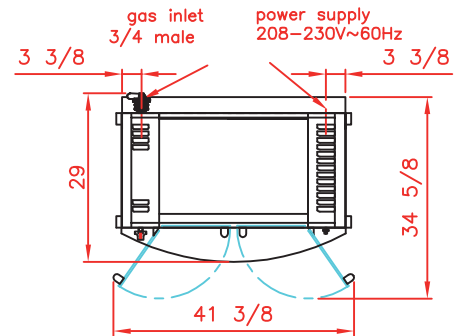

Side view
Rotisserie with roof

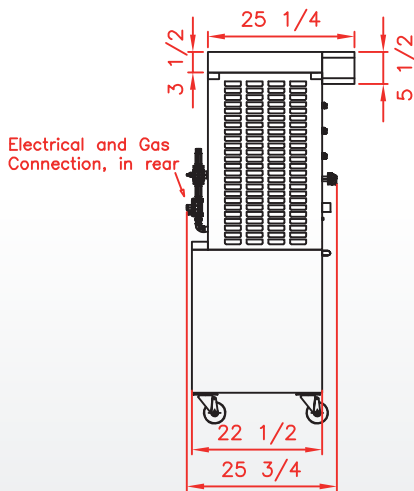

Revised
March 2018
March 2022 US



GF975-2G-SSP
Stainless steel with porcelain enamel
shown with optional lighted roof & base

SPECIFICATIONS

| | |
|--------------------------|-------------------------------|
| Capacity | 4-6 chickens |
| Gas power | 27500 BTU/h |
| Power supply | 208-230V / 60Hz, 1.15 amps |
| Electrical power | 0.24 kW |
| Weight and size (HxDxW) | 265 Lbs; 63 7/8 x 29 x 40 3/8 |
| Shipping weight and size | 400 Lbs; 69 3/8 x 30 x 42 1/8 |
| Warranty | 1 year parts and labor |

DISTRIBUTOR / AGENT

Rotisol France, Inc.
1450 W. 228th St. Unit 10, Torrance, CA 90501
info@rotisolusa.com
Ph: 310 671 7254
800 651 5969

