

# Trento Santos Citrus Juice Extractors

ITEM: 44025  
MODEL: SANTOS 11C

48110  
SANTOS 11



44025

48110

## Commercial juicer, built to last, with a heavy duty and quiet induction motor

The real commercial juicer, built to last, with a heavy duty and quiet asynchronous motor, for use everywhere you need a fresh squeezed citrus juice: juice bars, health food stores, hotels, bars, restaurants, cafeterias, ice cream shops, institutions, hospitals and even... at home.

### FEATURES:

- Delivered with 3 removable squeezers for oranges, lemons, limes and grapefruits.
- Easy to clean: removable bowl, grid and squeezer.
- Spout height: 125 mm (5"), to make juice in a glass.
- Average output: 30l/h
- Built to last, it has obtained the Longtime Label, attesting its robustness and durability!
- 100% manufactured in France since 1954.

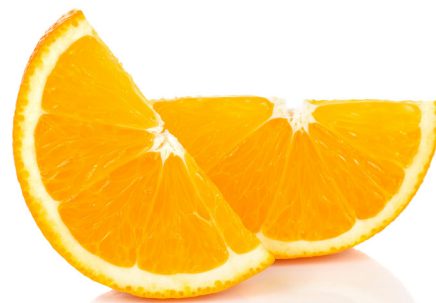

1-833-487-3686

[www.trentoequipment.com](http://www.trentoequipment.com)

[sales@trentoequipment.com](mailto:sales@trentoequipment.com)

Follow us on social media  
@trentoequipment



Authorized Dealer

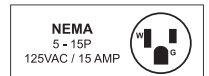



The unique juicer that you can clean quickly and easily. All the parts which are in contact with the fruits are easily removable (NSF approved).

1. 3 removable squeezers
2. Metallic ring
3. Grid
4. Plastic bowl

**EASY To Clean**

**Technical Specification**

Colour	Chrome	Green
Item	44025	48110
Model	SANTOS 11C	SANTOS 11
Production (Per Hour)	8-Gal (30-L)	
Power	155W/ 0.2hp	
Amps	1.4 A	
Electrical	100-120V/60Hz/1Ph	
RPM	1800	
Net Weight	11 lb. (5 kg.)	
Net Dimensions (WDH)	9" x 12" x 14" (230 x 300 x 350 mm)	
Gross Weight	12 lbs. (5.6 kg)	
Gross Dimensions (WDH)	10" x 13" x 16" (255 x 340 x 400 mm)	
Plug Type	NEMA 5-15P	

**Thermal Safety**

Motor protected by thermal detector and overload protector.

**Electrical Safety**

- On/Off interlock switch is waterproof
- All mechanical parts are ground (earth) connected
- All equipment is 100% tested at the end of assembly

**Acoustic Safety**

The asynchronous motor with direct drive is particularly silent

**Hygiene**

All removable parts can be put in a dishwasher or easily cleaned with hot soapy water (NSF approved)

**SAFETY And HYGIENE**

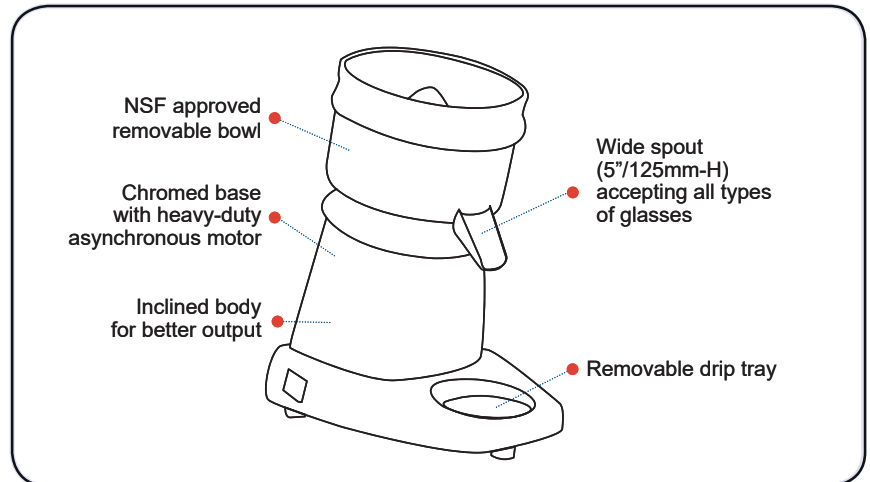

**PARTS And SPECIFICATIONS**

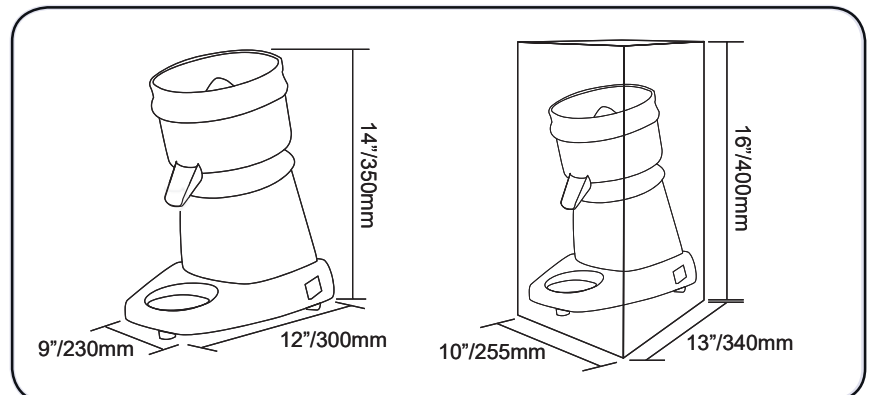

**DIMENSIONS**

