

Fusion

GHSSV 52"H Refrigerated Self-Service Case

Structural Concepts®

DELIVERING FRESH. ALWAYS.™

(Lengths do not include 1-1/8" end panels)

- **GHSSV452RLB** 48-3/4"L x 43"D x 51-5/8"H
- **GHSSV552RLB** 60-5/8"L x 43"D x 51-5/8"H
- **GHSSV652RLB** 73-1/8"L x 43"D x 51-5/8"H
- **GHSSV852RLB** 97-1/2"L x 43"D x 51-5/8"H
- **GHSSV1052RLB** 121-1/8"L x 43"D x 51-5/8"H
- **GHSSV1252RLB** 146-1/4"L x 43"D x 51-5/8"H

Included

- Integrated average product temperature of 40°F or less
- LED top & shelf lights
- One year parts & labor warranty
- Remote DX refrigeration
- Stainless steel rear exterior



GHSSV652RLB

Specify	Standard Features	Additional Options
EXTERIOR COLOR	• Laminate (stock colors)	• Laminate (non-stock colors) • Powder coated (stock/non-stock colors) • Powder coated Silversan Black • Stainless steel
INTERIOR COLOR	• Powder coated Silversan Black	• Stainless steel
LOWER FRONT PANEL COLOR	• Powder coated Silversan Black	• Powder coated (stock/non-stock colors) • Stainless steel
BASE SUPPORT	• Rail system for shims	
BUMPER FRONT	• 1" Boston bumper (specify color)	• 1" Stainless steel plate rail bumper
END PANELS	• Full w/stainless steel mirror interior	• Cutaway w/glass • None (specify per line-up)
PRICE TAG MOLDING	• None	• 1" Price tag molding (black or silver) • Universal price tag molding (clear w/ open top)
REAR DOORS	• None (solid back panel)	• Solid rear swinging doors
SHELVING	• 20" & 22" & 24" Solid shelving	• 20" & 22" & 24" Glass shelving
LIGHTS	• LED 3500K w/ frosted lens	• LED 4000K w/ frosted lens
ELECTRICAL CONNECTION	• Electrical leads (remote)	
REFRIGERATION	• Remote DX refrigeration	• Remote w/thermostat, solenoid & TXV
SENSOR	• None	• CPC discharge air sensor (remote)
MISCELLANEOUS		• Rear door lock
ACCESSORIES		• Drain strainer • Night curtain, retractable, non-locking • Removable wire security cover, locking

Intended Environment: Type I - Designed to operate in ambient conditions of 75°F with 55% relative humidity unless noted otherwise in system information below.		
Zone	Intended Product To Be Displayed	Warmest Avg Prod Temp ° F
1	Packaged refrigerated products	40

PLAN VIEW

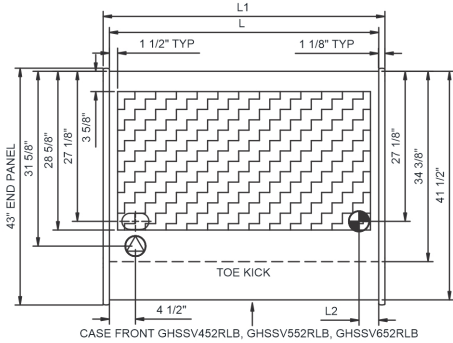

CASE FRONT GHSSV452RLB, GHSSV552RLB, GHSSV652RLB

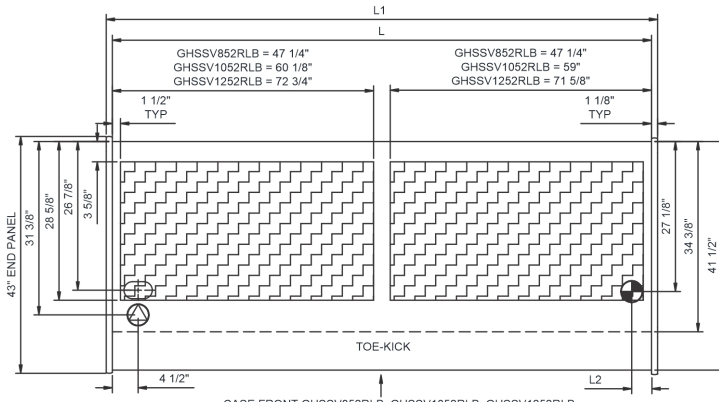

CASE FRONT GHSSV852RLB, GHSSV1052RLB, GHSSV1252RLB

SIDE VIEW

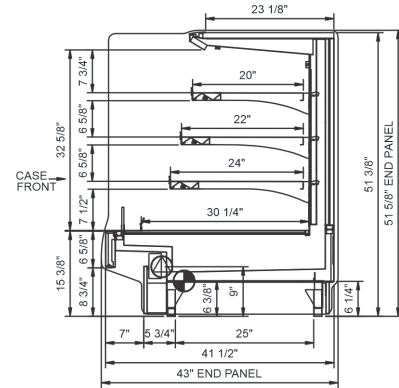

NOTE: ALL DIMENSIONS APPROXIMATE

- ELECTRICAL JUNCTION BOX (SUPPLIED WITH 6" LEADS OR POWER CORD).
- LOCATION OF DRAIN TUBE FOR REMOTE REF. ONLY (SUPPLIED WITH 3/4" OR 1 1/2" PVC TUBE).

- REFRIGERATION LINE CONNECTION.
- REMOTE FLOOR SINK & UTILITIES ACCESS AREA.

- SELF-CONTAINED CASE SERVICE ACCESS AREA.
- DRY CASE SERVICE ACCESS AREA.

Model Technical Specifications

Model	L"	L1"	L2"	System Circuit Volts	Circuit #1	Phs	Freq	Amps ***	Watts	Wires	NEMA Plug	SST	Conv. Rack BTUH	Para. Rack BTUH	Est Wt	
																Remote (DX)
GHSSV452RLB	48.75	51.00	4.63	Remote (DX)	Circuit #1	110-120	1	60	1.48	56	2+G	Leads Multiple	20.00	4622	4280	1,000
GHSSV552RLB	60.63	62.88	4.63	Remote (DX)	Circuit #1	110-120	1	60	2.26	149	2+G	Leads Multiple	20.00	6070	5620	875
GHSSV652RLB	73.13	75.38	3.63	Remote (DX)	Circuit #1	110-120	1	60	1.89	124	2+G	Leads Multiple	20.00	7517	6960	950
GHSSV852RLB	97.50	99.75	3.63	Remote (DX)	Circuit #1	110-120	1	60	2.96	163	2+G	Leads Multiple	20.00	9383	8688	1,375
GHSSV1052RLB	121.13	123.38	41.50	Remote (DX)	Circuit #1	110-120	1	60	3.07	192	2+G	Leads Multiple	20.00	10368	9600	1,750
GHSSV1252RLB	146.25	148.50	46.13	Remote (DX)	Circuit #1	110-120	1	60	5.21	375	2+G	Leads Multiple	20.00	13997	12960	2,500

*** Does not include electric defrost on freezer models.

Regulatory Approvals:

All Models
 Accordance with AHRI Std 1200
 ETL Listed to UL 471
 ETL Listed to CAN/CSA 22.2 No. 120
 ETL Sanitation to NSF/ANSI 7



In Accordance with
AHRI Std 1200

DOE 2017
 Energy Efficiency
 Compliant

Important Notes:

- ELECTRICAL NOTE: If GFCI is required, a GFCI breaker MUST be used in lieu of a GFCI receptacle.
- 45" minimum door entry clearance required (without shipping skid).
- Units must be shimmed during installation to ensure the unit is level and plumb.

⚠ WARNING: This product can expose you to chemicals, including Urethane (Ethyl Carbamate), which are known to the State of California to cause cancer and birth defects or other reproductive harm. For more information go to www.P65Warnings.ca.gov.