

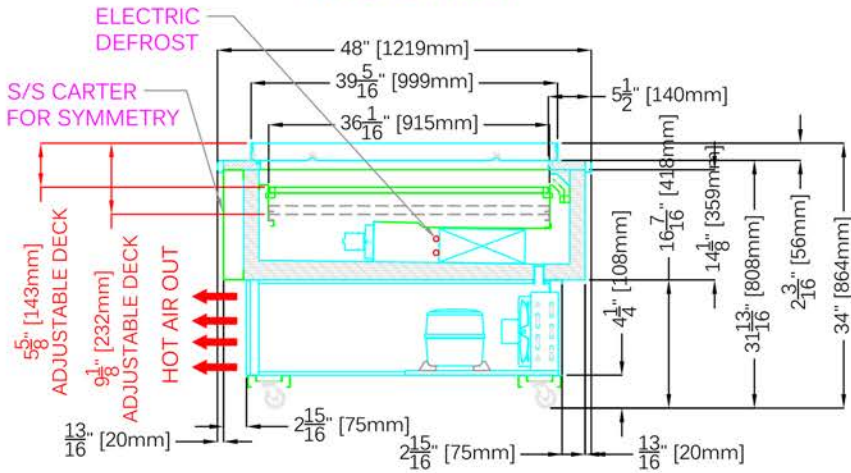

### SECTION VIEW

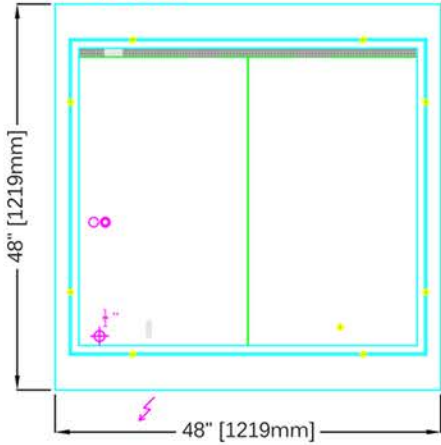

### HOT AIR OUT



### PLAN VIEW (OPERATOR SIDE)

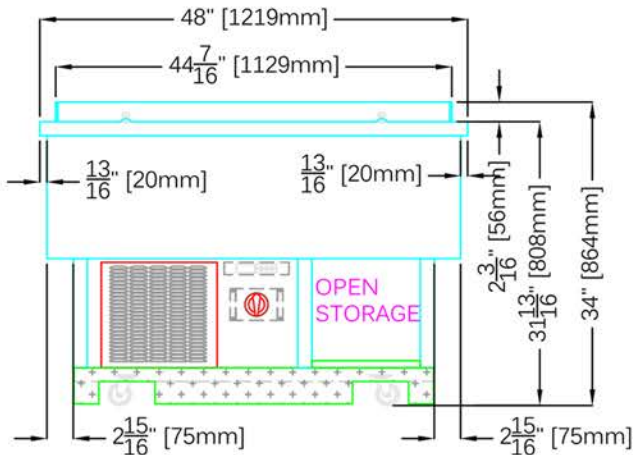

### REAR ELEVATION (OPERATOR SIDE)

### STANDARD FEATURES

- Adjustable deck
- Stainless steel lower interior foam tub
- Galvanized chassis structure
- Tempered glass deflector
- Self contained 120V/1ph/60Hz
- Electronic control system to maintain balanced temperatures
- Case ship standard unfinished

### OPTIONS

- Choice of color laminated exterior and interior
- Remote, water cooled

CENTRO		
TECHNICAL FEATURES		MODEL
		CENTRO
External Dimensions (L-D-H)	Inches	48" - 48" - 34"
	Inches-MM	1219 - 1219 - 864
Crated Dimensions (L-D-H)	Inches	55" - 55" - 40"
	Inches-MM	1397 - 1397 - 1016
Refrigeration	Type	Ventilated
Refrigeration Display Area	Type	Deck
Operating Temperature	°F	40°F
Compressor	Nr./Type	Hermetic
BTU'S @ +14°F Evap Temperature	BTU'S	5500 BTU'S
Electric Supply	(V/Ph/Hz)	120/1/60
Power Consumption	(A)	8A
Defrost	Mode/Type	Air
Refrigerant Gas	Type	R404A
Net Weights	Kg/Lb	120Kgs / 264Lbs
Crated Weights	Kg/Lb	150Kgs / 330Lbs

\* Manufacturer reserves the right to change specifications without notice. Not responsible for error and omissions.