

Project:



Scan for more info!

Owners manual
Quick install
Quick sizing
Install layout
Parts list

CBR-V2C-MINI Short height tower



Sparkling & chilled still water
Two faucet tower

Specifications

- Flow rate is adjustable to your liking and can be locked in a specific setting
- Faucet flow rate: 1.5-2 oz per second
- Two faucets for sparkling and chilled still water
- Height: 15.44”
- Bottle filling clearance: 7.7”
- Ergonomic handles
- Supplied with quick connect fittings for easy hook-up to our CR-4L38 trunkline
- For use and pairing with all Crysalli Remote Chillers
- Low profile design for positioning the tower over sinks, low overhead cabinet space, or on tall counters
- Weight: 12 lbs

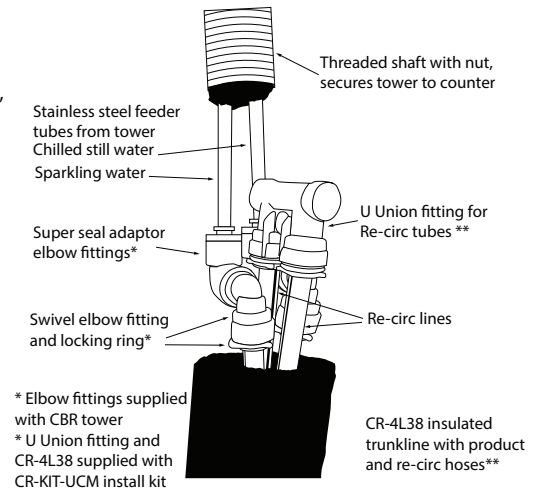
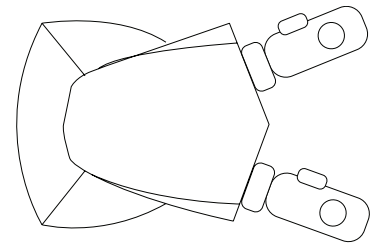
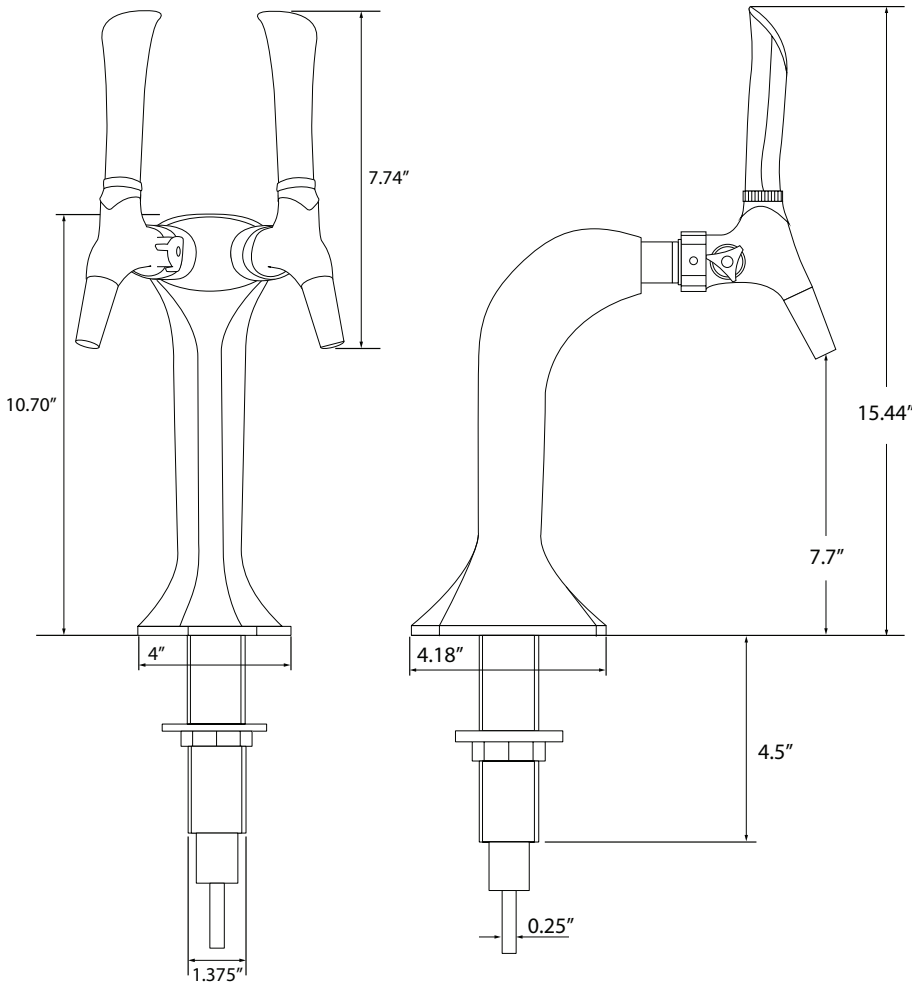

Accessories

- **CR-100301-C**
Optional chrome handles:



- **CR-MDLN-V2**
Optional medallion kit:



- **DP-CT**
Stainless countertop mount drain pan



Configured with a drain tube for direct plumbing



Or with rubber feet when no drain is available:

- **DP-CT-LD**
-

- **RDP-1SSQ-2CL**
Recessed drain pan



Overall 12" Wide x 15.125" Deep

