

Impulse

ITEM NO: _____
 PROJECT: _____
 DATE: _____

Product Specifications

Non-Refrigerated Self-Service Countertop Case

CSC3223

Lengths include end panels
 30-7/8"L x 22-5/8"D x 36-3/8"H



MODEL SHOWN: CSC3223

STANDARD FEATURES

- 6' straight blade power cord
- Black interior
- Black trim
- Glass end
- Glass swinging front doors
- Holds (4) 18" x 26" trays
- LED 3500K side lights
- Light switch in base
- NOTE: Trays not supplied with unit.
- One year parts & labor warranty
- Tray support non-lighted shelves, (trays not included)

Features	Standard	Options
BASE COLOR	<input type="checkbox"/> Gray base exterior	<input type="checkbox"/> Black base exterior
BASE	<input type="checkbox"/> 6"H base w/bag area	<input type="checkbox"/> 2"H solid base w/o bag area
FRONT DOOR GRAPHICS	<input type="checkbox"/> None	<input type="checkbox"/> Front door graphics (customer supplied)
HEADER GRAPHICS	<input type="checkbox"/> None	<input type="checkbox"/> Header sign graphics (customer supplied) <input type="checkbox"/> Header sign, plain
REAR	<input type="checkbox"/> Solid back panel	<input type="checkbox"/> Clear glass rear swinging doors w/o lock <input type="checkbox"/> Mirror back panel
MISCELLANEOUS		<input type="checkbox"/> Second year parts & labor warranty

Option Notes: 1 - Increases depth of case to 23-5/8"D

Impulse

Product Specifications

Intended Environment: Type I - Designed to operate in ambient conditions of 75°F with 55% relative humidity unless noted otherwise in system information below.		
Zone	Intended Product To Be Displayed	Warmest Avg Prod Temp ° F
1	Unpackaged non-refrigerated products	Ambient

PLAN VIEW

SIDE VIEW

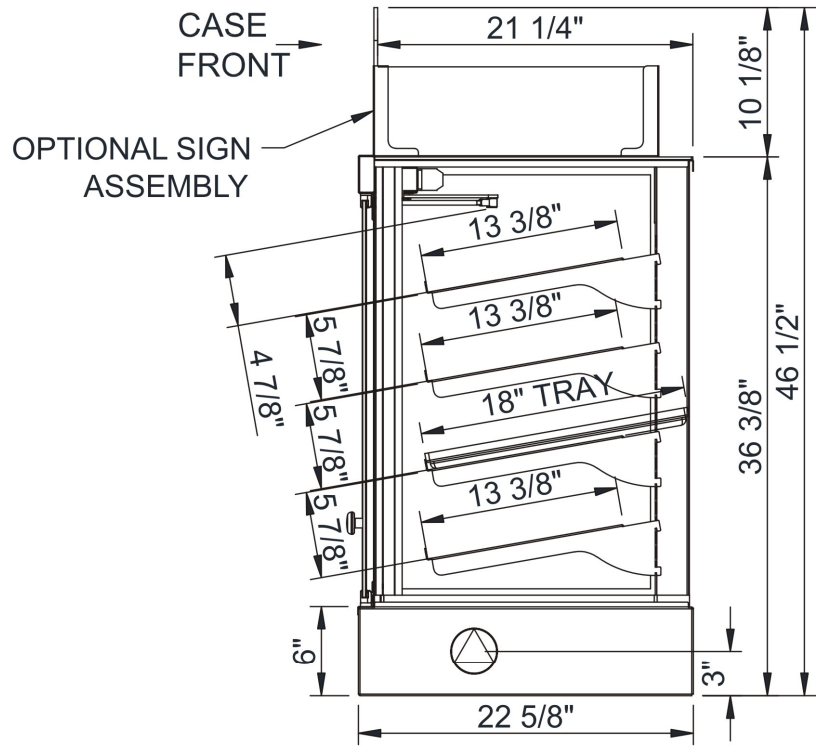
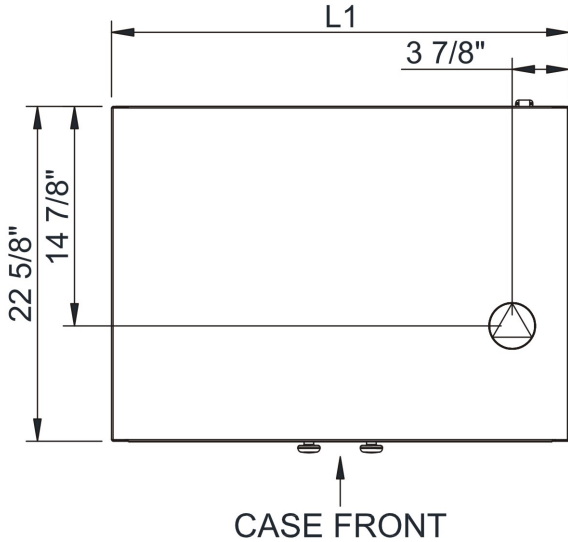

NOTE: ALL DIMENSIONS APPROXIMATE

- ELECTRICAL JUNCTION BOX (SUPPLIED WITH 6" LEADS OR POWER CORD).
- REMOTE FLOOR SINK & UTILITIES ACCESS AREA.
- LOCATION OF DRAIN TUBE FOR REMOTE REF. ONLY (SUPPLIED WITH 3/4" OR 1 1/2" PVC TUBE).
- SELF-CONTAINED CASE SERVICE ACCESS AREA.
- REFRIGERATION LINE CONNECTION.
- DRY CASE SERVICE ACCESS AREA.

Model Technical Specifications																
Model	L"	L1"	L2"	System Circuit Volts		Phs	Freq	Amps ***	Watts	Wires	NEMA Plug	SST	Conv. Rack BTUH	Para. Rack BTUH	Est Wt	
CSC3223	N/A	30.88	.00	Ambient/Lights	Circuit #1	110-120	1	60	0.70	7	2+G	5-15P	N/A	N/A	N/A	250

*** Does not include electric defrost on freezer models.

Important Notes:

- 1) ELECTRICAL NOTE: If GFCI is required, a GFCI breaker MUST be used in lieu of a GFCI receptacle
 - 2) 24 1/8" Minimum door entry clearance required (Without shipping skid).
- ⚠ WARNING:** This product can expose you to chemicals, including Urethane (Ethyl Carbamate), which are known to the State of California to cause cancer and birth defects or other reproductive harm. For more information go to www.P65Warnings.ca.gov.

Regulatory Approvals:	
All Models	ETL Listed to UL 65 ETL Sanitation to NSF 2

