

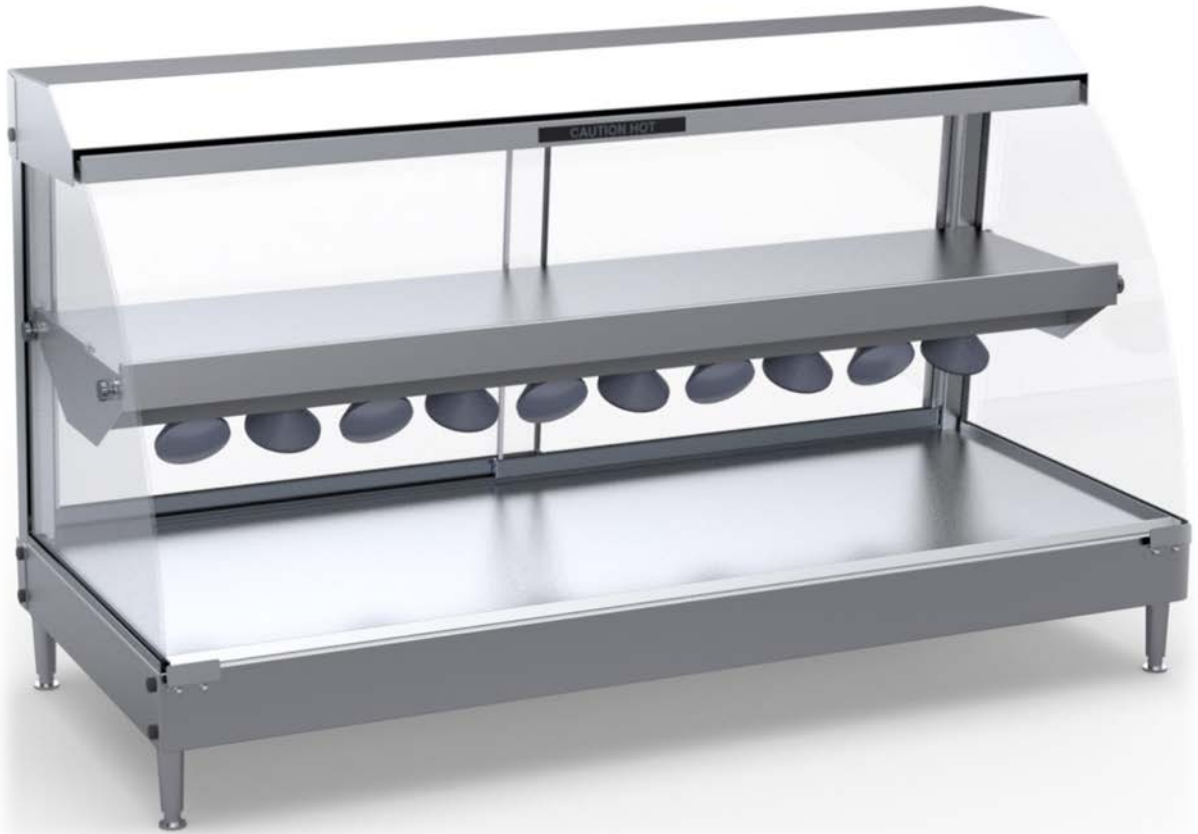

## 2-Tier Heated Display Case MODEL GM-4P2T



<b>Capacity</b> Accommodates 4 x Full-Size and 4 x Half-Size Pans
<b>No water connection</b> Hold and Display Food without the use of water (no water connection required)
<b>Condensation</b> No condensation build-up on glass
<b>Display</b> Euro-style Curved Glass (front & side panels).
<b>Wide-Beam Halogen Lighting</b> Enhances product view and stimulates sales
<b>Tempered Mirror Sliding Glass Doors</b> Framed and removable, making display more visible and simplifying the cleaning process
<b>Coated Shatterproof Lighting</b> Halogens
<b>Rubber Gaskets</b> Protects the glass edges from chipping
<b>Heavy Duty Construction</b> Manufactured with high-gauge 304 stainless steel

**RESFAB EQUIPMENT INC.**  
Toll Free: 1-866-359-0808  
[info@resfab.com](mailto:info@resfab.com) | [resfab.com](http://resfab.com)

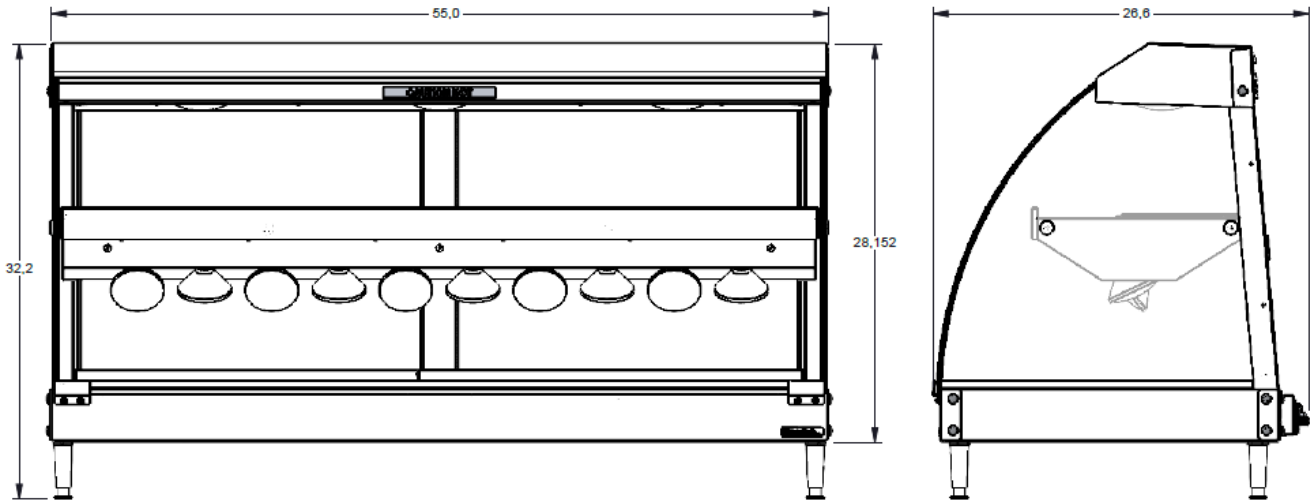

## ELECTRICAL

<b>MODEL</b>	<b>GM-4P2T</b>
VOLTAGE	120 V
AMPERAGE	21.5A
POWER CORD	10 ft
LIGHT BULBS (HALOGEN)	13 X 50W
PLUG & RECEPTACLE	NEMA 5-30P / 5-30R

## DIMENSIONS

WEIGHT	227 lbs
WEIGHT - CRATED	325 lbs
CRATE DIMENSIONS	W 63.1" x H 42.5" x D 31.0"

## INSTALLATION REQUIREMENTS

- DISPLAY CASE MUST BE INSTALLED LEVEL
- USE THE 4 LEGS OR SEAL THE CASE TO THE COUNTER WITH NSF FOOD GRADE CAULKING

