



BEVERAGE-AIR

Project: _____	AIA#
Item: _____	
Location: _____	SIS#
Approved: _____	

WTFCS52HC CHEF BASE FREEZER

CHEF BASE FREEZER

WTFCS52HC Two Drawer With Extended Top Chef Base Hydrocarbon Series

MODEL:
WTFCS52HC-60



**7 Year Parts/Labor Warranty
7 Year Compressor Warranty**

CABINET CONSTRUCTION

- Stainless steel front, sides, drawers and grille (galvanized back & bottom)
- Interior liner is made of corrosion resistant aluminum
- 60" Extended top has full marine edge to prevent spills from dripping over sides
- Full electronic control
- Top weight capacity 1000 lbs
- One-piece, snap-in magnetic drawer gasket
- 12-Gauge stainless steel drawer slides with Delrin® rollers rated at 275 lbs
- Lifetime warranty on all drawers and slides
- Heavy duty, fire-proof, insulated 16 gauge top
- No heat shield required (must adhere to proper clearance per owners manual)
- Accommodates 6" deep full size food service pans (not included)
- Self-closing drawer feature
- Compressor available on left or right, specify at time of unit order
- 3" Casters, 2 with brakes standard

OPTIONS & ACCESSORIES

- Stainless steel back
- Stainless steel interior
- Additional pan supports
- 6" Adjustable legs, 6" seismic legs
- 6" Casters
- Gasket guards
- Remote option*
(refrigerant must be specified at time of order, see note on back on page)

REFRIGERATION SYSTEM

- Uses environmentally friendly, energy efficient R290 refrigerant, and meets all regulatory requirements for CARB, SNAP, DOE & more
- Adaptive defrost
- Non-electric defrost with hot gas condensate evaporation
- Freezer capable of maintaining product temperature of -10°F



Please verify qualifying units by visiting:
www.energystar.gov/cfs

3779 Champion Blvd., Winston-Salem, NC 27105
1-888-845-9800 Fax: 1-336-245-6453
Beverage-Air.com Sales@bevair.com



BEVERAGE-AIR

MODEL	WTFCS52HC-60
EXTERNAL DIMENSIONAL DATA	
Width Overall	60"
Depth Overall (with handle & bumper)	34 3/4"
Height Overall (with casters)	24 3/8"
No. of Drawers / Pans	2 / 4 Full size
Depth with Drawers Extended	59 7/8"
Drawer Openings	(2) 27 3/8" x 6 1/2"
INTERNAL DIMENSIONAL DATA	
NET Capacity (cubic ft.)	8.06
Internal Width Overall (in)	38"
Internal Depth Overall (in)	22 3/8"
Internal Height Overall (in)	16 3/8"
ELECTRICAL DATA	
Full Load Amperes	5.0
REFRIGERATION DATA	
Horsepower	1/2
Capacity (BTU/Hr)	1725
Heat Rejection (BTU/Hr)	2588
Charge (lbs/grams/ounces)	0.287 / 130 / 4.59
WEIGHT DATA	
Gross Weight - Crated	400 lbs
Height - Crated	27"
Width - Crated	58"
Depth - Crated	38"

*NOTE: Remote units are field wired and come with 6" legs. Refrigerant must be specified at time of order.

We reserve the right to change specifications and product design without notice. Such revisions do not entitle the buyer to corresponding changes, improvements, additions or replacements for previously purchased equipment. Dimensional tolerances +/- 1/4". Metric dimensions (MM).

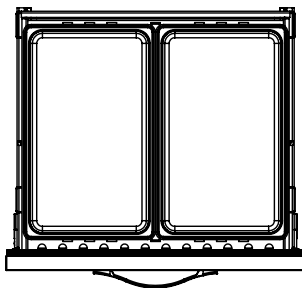

(Per drawer)

Chef Base Freezer with Extended Top Model: WTFCS52HC-60

Model Views

Required Clearance: Bottom 3 1/4" & Rear 1"

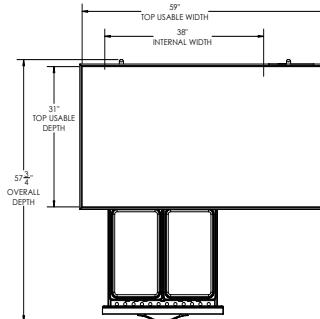

PLAN VIEW

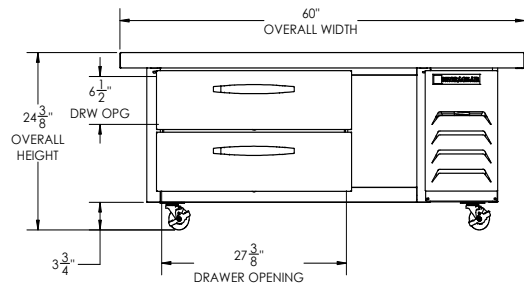

ELEVATION VIEW

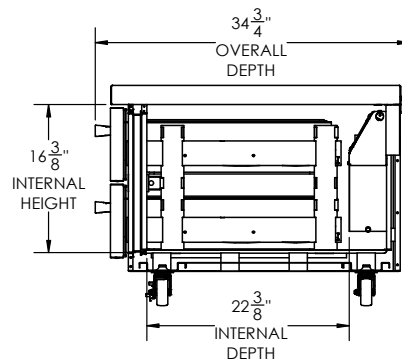

SIDE VIEW

ELECTRICAL CONNECTION



115/60/1
NEMA 5-15P

Unit pre-wired at factory and include 8' long cord and plug set.

