

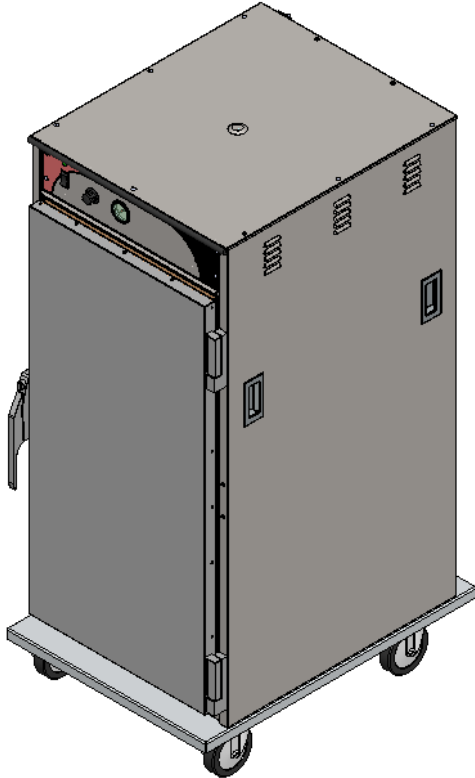

# Temper Select Heated Holding Cabinet

Innovative Foodservice Equipment Custom Designed For Performance, Service and Value

## Quality Proofing and Holding Cabinets



Model HTSS60P12

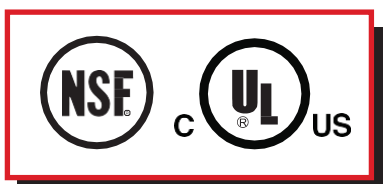

3/4 SIZE  
NARROW WIDTH MODEL

HTSS60P12

### Standard Features:

- Temperature adjustable from 60°F (15.6°C) to 215°F (102°C) for heating and holding a variety of foods
- Top mounted convection heat and humidity system maintains even cabinet temperatures and ensures quick pre-heating and rapid recovery
- Removable top water pan provides additional humidity for hard to hold items
- Solid state controls provide the highest degree of accuracy and reliability, prepared foods are held at a consistent serving temperature
- Fully insulated cabinet prevents heat loss and keeps foods hot and ready to serve, side air tunnel system circulates air evenly throughout the cabinet with minimal heat loss when doors are opened
- Completely removable interior components for quick and easy cleaning
- Pan slide assemblies hold 18 x 26 sheet pans, optional welded wire screens accept 12 x 20 steam table pans
- All stainless steel & aluminum construction
- Heavy-duty plate-type casters with 5" hard neoprene wheels, front two with brakes
- Heavy duty field reversible doors with self closing lift off hinges and magnetic latches
- Magnetic door gaskets
- Recessed stainless steel side mounted (front and rear) pull grips provide easy mobility
- 120V, 15A, 1PH service standard NEMA 5-15P



NEMA 5-15



# Temper Select Heated Holding Cabinet

Item No. \_\_\_\_\_  
 Approval: \_\_\_\_\_  
 Date: \_\_\_\_\_

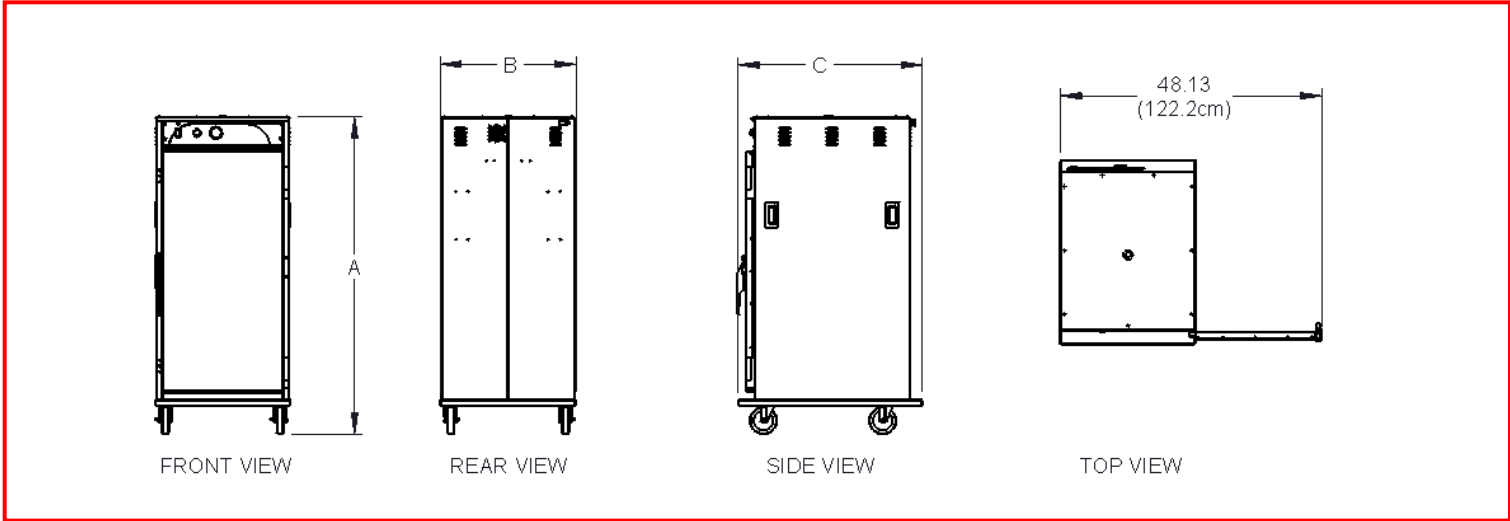

BEVLES MODEL NO.	CAPACITY 18x26   12x20   *SPC'G	DIM A (H) IN   CM	DIM B (W) IN   CM	DIM C (D) IN   CM	INSIDE HGT IN   CM	SHIP WT. LBS   KGS	ACTUAL WT. LBS   KGS
------------------	------------------------------------	----------------------	----------------------	----------------------	-----------------------	-----------------------	-------------------------

### Proofing and Holding Cabinets

HTSS60P12	12	12*	3	58.50	149	25	63.5	34	87	43	109.2	280	127	230	105
-----------	----	-----	---	-------	-----	----	------	----	----	----	-------	-----	-----	-----	-----

\* With optional 18" x 26" welded wire racks

ELECTRICAL	VOLTAGE	WATTS	AMPS	ELECTRIC SERVICE	PHASE	HERTZ	CLEARANCES
STANDARD	120	1200	10	15A Dedicated Circuit	1	60	ZERO CLEARANCE CABINET
OPTIONAL	208-230	2000	9.7/8.7	15A Dedicated Circuit	1	50/60	ZERO CLEARANCE CABINET

**Construction:**

- Exterior 20 ga 304 #3 finish stainless steel
- Interior 22 ga 304 2B finish stainless steel
- Exterior door panel 20 ga 304 #3 stainless steel
- Interior door panel 22 ga 400 BA finish stainless steel
- Internal framework 18 ga 304 stainless steel
- Full insulated doors, back, sides, top and base
- Latch Heavy duty magnetic door latch with cool-to-touch handle and turn knob lock
- Hinges Heavy duty lift off self-closing, chrome plated
- Door Gasket Magnetic NSF approved Santoprene
- Base: .125 Formed aluminum with welded corners
- Side air ducts 22 ga 304 2B Stainless steel

**PAN SUPPORTS:**

- Pan Supports .063 formed aluminum on 3" centers

**HEATING MODULE & CONTROLS:**

- Top mounted dual coil heating unit , heating elements rated at 600watts @ 120v, or 1000 watts @ 208-230v
- Easy to operate controls feature 20 amp rated rocker switch, and pilot light, precision variable thermostat, 2" dial thermometer

- Cord and Plug: 8' cord with 15A molded plug (NEMA 5-15P); 208/230 volt models provided with cord only

**CASTERS:**

- Heavy-duty plate type casters, with 5" hard neoprene wheels; all swivel, with wheel brakes on front two casters

**OPTIONS AND ACCESSORIES**

- Left hand door hinging
- Stainless steel push handles
- Magnetic latch with key lock
- Corner bumpers of gray non-marking vinyl (set of 4)
- Perimeter bumper of gray non-marking vinyl
- Additional universal pan supports
- 6" stainless steel legs with adjustable feet for stationary floor installation\*
- 6" casters with soft rubber wheels
- 18" x 26" chrome electroplated wire racks
- 208-230-50/60Hz electrical service

\* Note: Modifications involving casters or legs may affect height of equipment. Specifications subject to change without notice