

# OPEN AIR MERCHANDISERS

## HORIZONTAL · 35" DEEP · SHORT

Project Name: \_\_\_\_\_

Project Location: \_\_\_\_\_

Model #: \_\_\_\_\_ Quantity: \_\_\_\_\_

Available Warehouse: \_\_\_\_\_

### EOMH Series Model: EOMH-60-B-35-S



#### Refrigeration System

- Bottom mounted, self-contained and fully detachable Blizzard R290 condensing unit uses environmentally friendly, EPA-compliant R290 refrigerant with zero (0) Ozone Depletion Potential (ODP) and three (3) Global Warming Potential (GWP). Blizzard R290 is easily replaceable and requires no on-site brazing.
- Front air intake and rear air discharge design allows side by side installation.
- Conforms to **NSF Standard 7 TYPE II (maximum ambient temperature 80°F)**.
- Electronically commutated (ECM) evaporator fan motors achieve rapid cooling with less energy consumption.
- High performance, auto-reverse condenser fan motor supports compressor ventilation and condenser coil cleaning. Refer to owner's manual for full maintenance instructions.
- Large capacity, corrosion-resistant condenser and evaporator coils.
- Self-maintaining, energy-efficient condensate drain pan requires no external drains or electric heaters.
- Pre-wired and ready to plug, 115V/60Hz/1Ph, NEMA 5-20P.

#### Cabinet Construction

- Black or white modern exterior has moisture-resistant panels and field-replaceable tempered glass.
- Heavy-duty stainless steel interior has perforated back wall for efficient air flow. Includes floor drains for ease of cleaning.
- Galvanized steel top, bottom and rear.
- 2.5" thick high-density polyurethane insulation.
- Integrated retractable night curtain saves energy and provides security.
- 5" swivel casters with locks on front set. Leg stabilizers standard for all models.

#### Lighting

- Shielded LED bar lighting under shelves and canopy provide bright, high color illumination at lower heat output. On/off switch saves energy.

#### Shelving

- Removable 2-tier stainless steel shelf riser.

#### Temperature Control

- Factory preset temperature of 35°F maintains a combined average product temperature of 40°F or less.
- Audible overheat protection alarm for compressor and condenser coil.

#### Recommended Operating Conditions

- Conforms to **NSF standard 7 TYPE II** designed to operate in an air-conditioned environment where **temperature and humidity do not exceed 80°F and 55% relative humidity**.
- Must not be installed near ventilation systems, fans or exterior doors or windows that will disrupt the air curtain and compromise the function of the cabinet.
- Must not be installed in direct sunlight.
- In built-in applications, a distance of 6" is required on the front, back and top exterior for ventilation purposes.



Please visit our website for updated Energy Efficiency information

| Ref/<br>Frz/Dual | Capacity<br>Cu. Ft. | Shelves | NEMA Config | Refrigerant | HP      | Power<br>V-Hz-Ph | Amps | Crated<br>Weight | Exterior Dimensions |                   |                 |
|------------------|---------------------|---------|-------------|-------------|---------|------------------|------|------------------|---------------------|-------------------|-----------------|
|                  |                     |         |             |             |         |                  |      |                  | L                   | D                 | H*              |
| REF              | 9.3                 | -       | NEMA 5-20P  | R-290       | 1/2 x 2 | 115-60-1         | 10   | - lbs<br>(0kg)   | 60"<br>(1524mm)     | 34.25"<br>(870mm) | 41"<br>(1041mm) |

(†)Based on evaporating temperature of 23°F (-5°C) & condensing temperature of 131°F (55°C). (►) Product capacity is calculated based on standard industry figures. (✳) Reference plan view for clarification on caster/unit height. If dimensions and capacity are critical, please contact Everest Refrigeration. Blizzard R290 replacement is at the sole discretion of Everest Refrigeration. Specifications subject to change without notice.

# OPEN AIR MERCHANDISERS

## HORIZONTAL · 35" DEEP · SHORT

### EOMH Series Model: EOMH-60-B-35-S

#### DIMENSIONAL DATA

|                          |              |                |
|--------------------------|--------------|----------------|
| External Dimensions      | L            | 60" (1524mm)   |
|                          | D            | 34.25" (870mm) |
|                          | H*           | 41" (1041mm)   |
| Crated Weight            | - lbs. (0kg) |                |
| Doors/Drawers/Lids       | -            |                |
| Max Weight Support (LBS) | -            |                |

#### STORAGE DATA

|                        |     |
|------------------------|-----|
| Net Capacity Cu. Ft. ▶ | 9.3 |
| Shelves                | -   |
| Barrels                | -   |
| 20 oz. Bottles         | -   |
| 12 oz. Bottles         | -   |
| 12 oz. Cans            | -   |
| 8" Mugs                | -   |
| # of Pans (Top)        | -   |
| # of Pans (Drawer)     | -   |
| Dividers               | -   |
| Trays                  | -   |

#### ELECTRICAL DATA

|                        |              |
|------------------------|--------------|
| Voltage                | 115-60-1     |
| Full Load Amperage     | 10A          |
| Feed Wires with Ground | 3            |
| Cord Length            | 9ft          |
| NEMA Plug Type         | ⊖ NEMA 5-20P |

#### REFRIGERATION DATA

|                     |         |
|---------------------|---------|
| Compressor Mounting | Bottom  |
| Refrigerant         | R-290   |
| Compressor HP       | 1/2 x 2 |
| BTU/HR †            | 9       |

#### KEY

|    |            |      |               |
|----|------------|------|---------------|
| D  | Door       | R    | Refrigerator  |
| L  | Lid        | REF  | Refrigerator  |
| H  | Half Door  | F    | Freezer       |
| FD | Full Door  | FRZ  | Freezer       |
| SD | Solid Door | DUAL | REF/FRZ Combo |
| GD | Glass Door | DR   | Drawer        |

|  |           |       |      |    |      |
|--|-----------|-------|------|----|------|
|  | Elevation | Right | Plan | 3D | Back |
|  |           |       |      |    |      |

#### PLAN VIEW

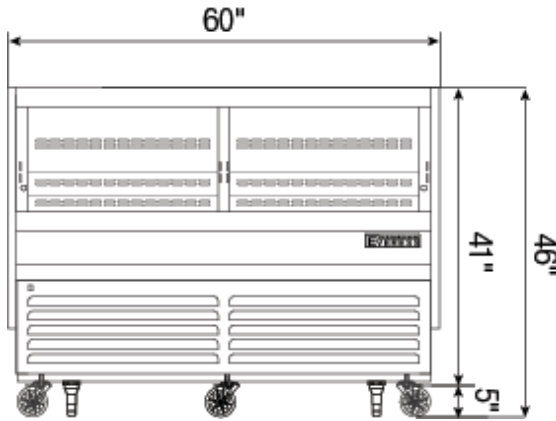

FRONT

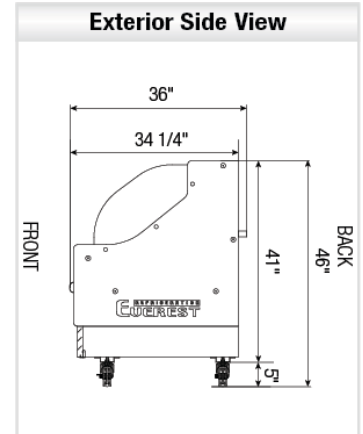

SIDE

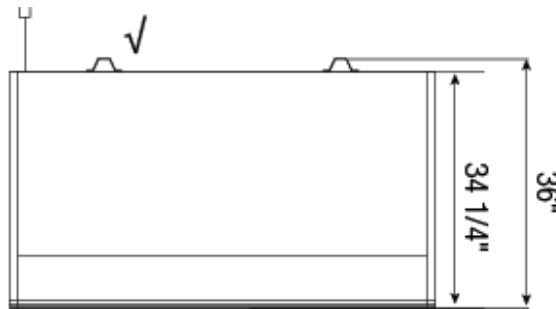

TOP

#### ACCESSORIES & OPTIONS

| Part Number | Description |
|-------------|-------------|
|-------------|-------------|

(†)Based on evaporating temperature of 23°F (-5°C) & condensing temperature of 131°F (55°C). (▶) Product capacity is calculated based on standard industry figures. (✳) Reference plan view for clarification on caster/unit height. If dimensions and capacity are critical, please contact Everest Refrigeration. Blizzard R290 replacement is at the sole discretion of Everest Refrigeration. Specifications subject to change without notice.