

ALFA FOOD WARMERS



ALFA EXCLUSIVE



FW9000



Specifications:

- Voltage: 120V AC, 60HZ, 1PH
- Warming Power: 1200 Watts
- Amperage: 10 Amps
- Well Capacity: 4.5 Quarts of hot water
- Outside Dimensions: 24" L, 13-1/4" W, 10" H
- Inside Dimensions: 20" L, 12" W, 6" H

ALFA #	DESCRIPTION	SHIPPING WEIGHT
FW9000	Single Warmer with Spigot	30 lbs.
FW9002	Double Warmer with Spigot	35 lbs.
FW9003	Triple Warmer with Spigot	37 lbs.

WARRANTY: 6 Months

Alfa's heavy-duty stainless steel Food Warmers with the easy-draining spigot have become an industry standard!

- Mirror-polished 18/8 Stainless Steel Exterior
- EZ-DRAIN front spigot makes draining water easy and safe
- Energy-saving thermostatically-controlled element heats only when needed
- Water-resistant Switch Cover
- Standard 12" x 20" well accepts most popular pans
- 65" Cord; 3-prong grounded plug

FW9003

Includes all the features of the FW9000 above plus 3 stainless steel 5-qt. inserts with ladles, lids and product cards with holders.

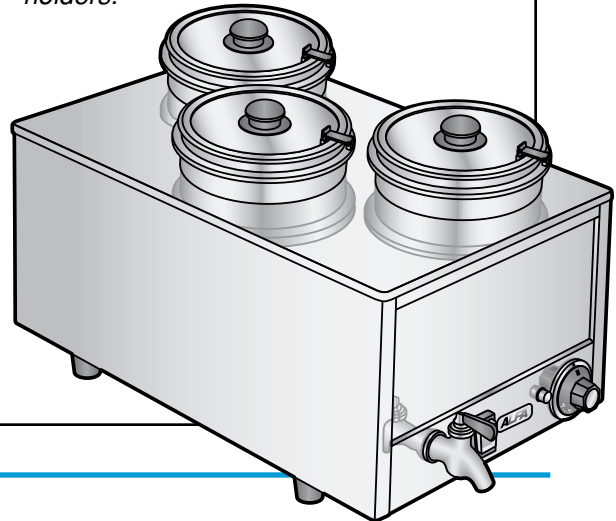

HOT PLATES from



- Completely portable
- Adjustable thermostat - 100° F to 450° F
- Heavy cast aluminum and Stainless Steel
- Nonstick cover easily replaced
- Can be used for heat shrinking of small packages



MADE IN THE USA

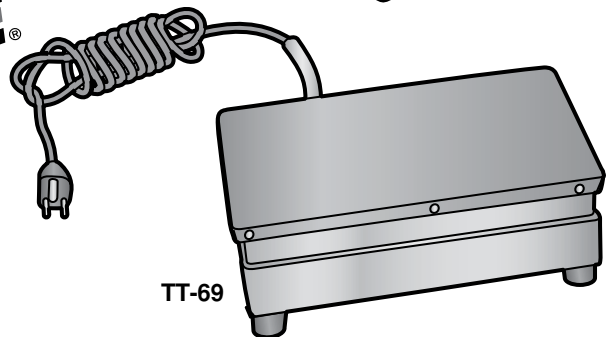

TT-69

ALFA #	DESCRIPTION	SIZE	WEIGHT	CORD
TT-69	Hot Plate	6" x 9"	5 lbs.	6-1/2 Ft.
TT-912	Hot Plate	9" x 12"	9 lbs.	5 Ft.
HS5905	Non-Stick Cover	9" x 12"	1 lb.	-

Electrical Specifications:
115 volts