

MADE IN ITALY



BISTROT RACK 16T BISTROT 6T & BISTROT 10T

## Standard Features

- AISI 304 Stainless-Steel Rounded Cooking Chamber Construction for better air circulation & cleaning
- Polypropylene (PP) Exhaust Piping (external)
- Double low emissive glass thermal insulation \*\*\*
- Openable inner glass for easy cleaning
- Boiler-less system
- Nine cooking modes available including Preset Programs, Manual mode, and Customized Programs mode
- 300 Preset Recipes, Storage of up to 1000 recipes, can customize 700 with up to 10 Steps Each
- Integrated WiFi settings
- A 3" between each tray
- Tray holders included
- Storage, viewing\* and exporting of cooking data- Pre-loaded and Online cookbook
- Multipoint core probe (5 Reading points), non-removable (housing integrated in tray-holder)
- Set-up for vacuum core probe
- Multi-fan system: 5 fan speeds & Fan inversion
- Multi-timer function for multiple and mixed cooking
- Automatic control of the cooking level and load
- Automatic Preheating & Cooling
- Delayed start programming & Automatic chimney opening
- Chamber Relative Humidity % Control with probes: Automized, by selected Percentage/Time, and Manual steam injection
- Self-Cleaning/Disinfection System
- Automatic detection and errors report
- LED illumination
- Ventless option when coupled with BISTROT Hood:

BISTROT 6T & BISTROT 10T

1-year parts and labor warranty (US Only)

Models:

BISTROT 6T / BISTROT 10T  
BISTROT RACK 16T



BISTROT 6T



BISTROT RACK 16T



Touch Screen



USB Port



### BISTROT HOOD

Coupling the BISTROT Hood with the Combi oven allows it to function as a **Ventless** unit (BISTROT 6T and BISTROT 10T)

Oven Stand



### Cooking Programs Available

- Delta T cooking with core probe,
- Pasteurization cooking,
- Convection cooking,
- Vacuum cooking,
- In-vase cooking,
- Steam Cooking,
- Mixed Cooking,
- And More!

### \*\*\*Double Low Emissive Glass\*\*\*

#### Thermal Insulation

Air gap between internal and external glass allows outer glass to be touched by the operator.  
The Internal glass has a reflective side to help retain the heat in chamber.

SPECIFICATIONS			
	BISTROT 6T	BISTROT 10T	BISTROT RACK 16T
Max Temperature	518°F (270°C)		
Tray Capacity 24"x16" (60x40cm) 18"x26" (46x66cm)	6	10	16
Power Supply	230V/50-60Hz/1-3ph (field convertible)		
Power (kW)	10	15	32
Amps	1ph = 48.3 3ph = 27.9	1ph = 72.5 3ph = 41.8	3ph = 93
Plug / Connection	No Plug - No Cord		
Product Dim. W x D x H	33.5" x 36.6" x 32.7" 85 x 93 x 83 cm	33.5" x 36.6" x 45.3" 85 x 93 x 115 cm	33.5" x 37.9" x 73.2" 85 x 96.3 x 186 cm
Product Weight	183 lbs (83 Kg)	247 lbs (112 Kg)	390 lbs (177 Kg)
Shipping Dim. W x D x H	36.2" x 39.4" x 38.6" 92 x 100 x 98 cm	36.2" x 39.4" x 51.2" 92 x 100 x 130 cm	37.4" x 41" x 82.3" 95 x 104 x 209 cm
Shipping Weight (lbs)	223 lbs (101 Kg)	291 lbs (132 Kg)	430 lbs (948 Kg)

OPTIONAL Accessories	BISTROT 6T	BISTROT 10T
Hood	Bistrot Hood	
Stand	6T STAND	10T STAND



#### Notes:

- Operate at room temperature between 41° and 104°F (5° and 40°C).
- Clearance of 6" required on all sides
- If the oven is positioned next to other units that give off heat (e.g. fryers), appropriate measures must be taken, such as placing protection against radiance.
- Maximum water hardness of 5°F
- Properly clean and dry after daily use to ensure best performance and equipment longevity.



No Plug  
No Cord

\*AMPTO is continuously improving products. Specifications are subject to change without notice.\*

## FRONT VIEW

## REAR VIEW

### BISTROT 6T

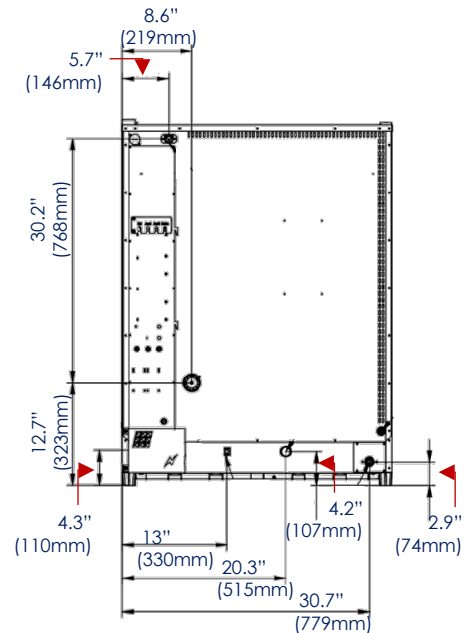
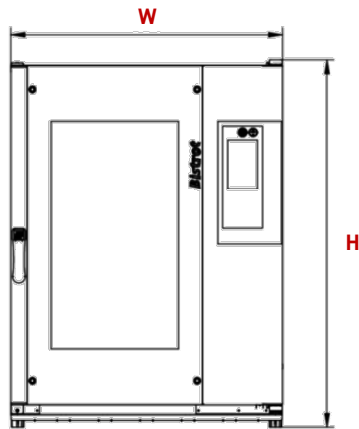
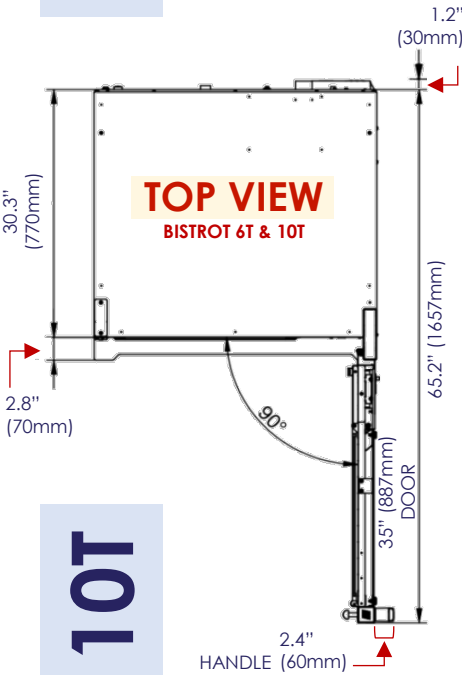
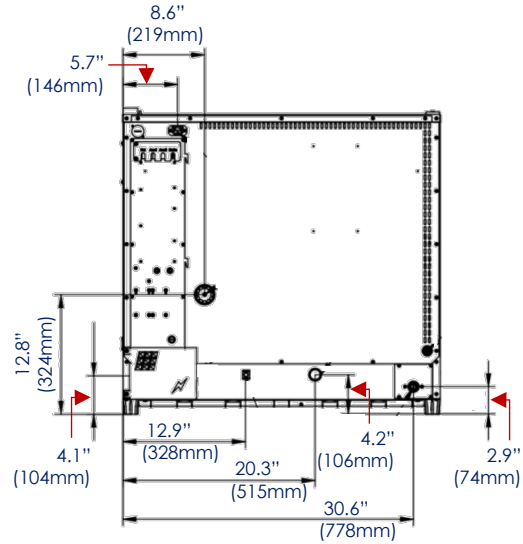
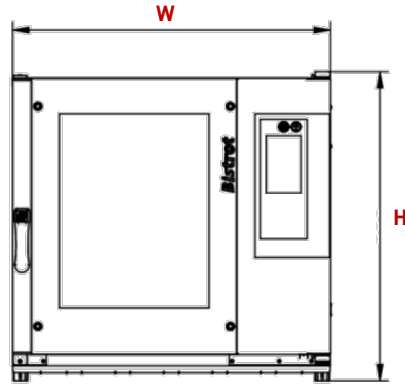

### BISTROT 10T

# BISTROT RACK 16T

**FRONT VIEW**

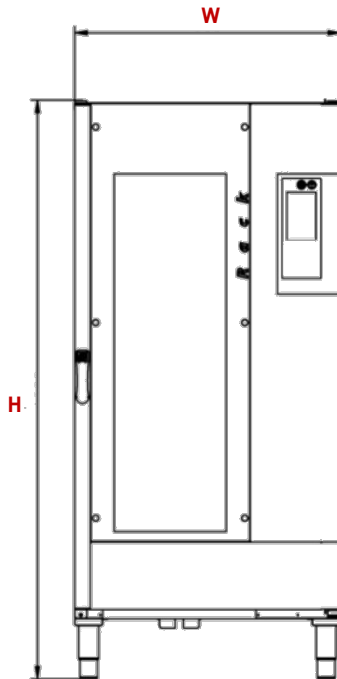

**REAR VIEW**

