

Project: _____
 Location: _____
 Item #: _____ Quantity: _____
 Model #: _____

MODEL: IRR-AGN301BT **REACH-IN: Slimline Reach-in Freezer**



General Strengths

- ✓ **Sanitation.** The interior cabinet is built with rounded corners (extensive radius for easy cleaning). Quick ability to take off shelves and slides for interior cleaning. Each cabinet has a drain at the bottom of the unit. When cleaning the unit make sure the drain hose is routed to a floor drain.
- ✓ **Doors.** Self-closing door system with permanent pressure. Stay open feature included when door remains open after 95 degrees. All doors include triple chamber door gaskets, easy to remove and snap in. Doors are field reversible.
- ✓ **Control systems.** Higher precision in managing temperature settings. Greater ability for the adjustment of temperatures ranges as per the end user's requirement.
- ✓ **100% Tested.** All condenser units are tested 100%, in helium chambers to refrigerant leak detections.
- ✓ **Certified.** Audited and Certified by **INTERTEK** for compliance with UL 471 and NSF 7. EQA audited and certified by internationally recognized firm. ISO 9001:2008 (Quality); ISO 14001:2004 (Environmental); OSHAS 18001:2007 (Prevention and Worker Safety)
- ✓ **Lighting.** LED lighting in cabinet sides reduces the energy consumption by 80% and 90% compared to a traditional bulb. Provides a much better light quality.

MODELS	Dimensions (inches) (mm)			Doors	Shelves	Ref.	Ref.Weight (Lbs.) (gr.)	Temperature Range (°F) (°C)	Cond. Unit (H.P)	Capacity (Cu.Ft.)	Case Amps 115V	Net weight (Lbs.) (Kg.)
	W	D	H									
IRR-AGN301BT	19 (482)	27-7/8 (709)	82-1/16 (2085)	1	3	R452A	0,66 (300)	-0,40°F (-18°C)	3/8"	11,47 (325)	5,6	265 (120)

ETL LISTED TO UL471 STANDARD AND SANITATION CLASSIFIED TO NSF7 – WE RESERVE THE RIGHT TO CHANGE SPECIFICATIONS WITHOUT PRIOR NOTICE



MODEL: IRR-AGN301BT **REACH-IN: Slimline Reach-in Freezer**

STANDARD FEATURES

➤ **Exterior**

- AISI 304 Stainless Steel,
- Completely injected compact structure.

➤ **Interior**

- AISI 304 Stainless Steel,
- Wide rounded corners to aid cleaning,
- LED lighting.
- Internal drain.

➤ **Doors**

- Self closing with stay open feature,
- Stainless Steel covered hinges,
- Triple chamber snap in door seals for easy removal,
- Door lock provided.
- Integrated door handles

OPTIONAL FEATURES

- ✓ Extra-dense Wire Shelf.
- ✓ Slides Kits.
- ✓ Set of 6” legs, height adjustable from 5” to 8”.
- ✓ Electrical connection is 230V / 1ph / 50 Hz (plug type varies).

➤ **Insulation**

- Polyurethane with high density 40kg/m³, CFS free, zero ODP and low GWP.

➤ **Shelving**

- (3) Plastic-coated wire shelves per door,
- Set of Stainless Steel rails per shelf included,
- Dimensions WxD: 21”x 13” (530x325 mm),

➤ **Casters**

- 4” diameter casters,
- Locks provided on front set.

➤ **Refrigeration**

- Temperature and defrost regulated by a digital controller,
- Evaporative pan,
- Evaporator coil coated with anti-corrosion material,
- Refrigeration capacity: 1228 Btu/h (-22°F) / 360 W (-30°C).
- Expansion valve
- Hot gas defrost

➤ **Electrical**

- Cord and NEMA 5-15P plug,
- Electrical connection is 115 V / 1ph / 60 Hz.



MODEL: IRR-AGN301BT **REACH-IN: Slimline Reach-in Freezer**

ELEVATION RIGHT VIEW PLAN VIEW

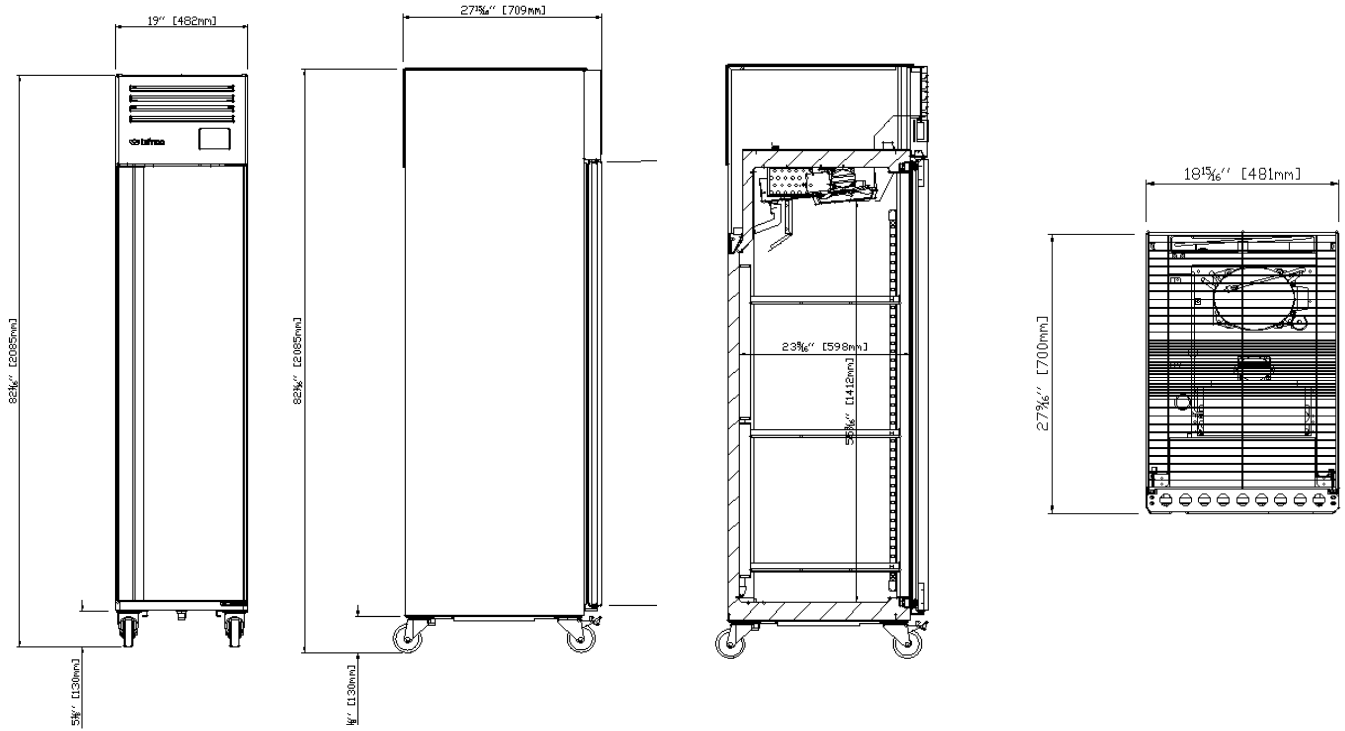

CONNECTION

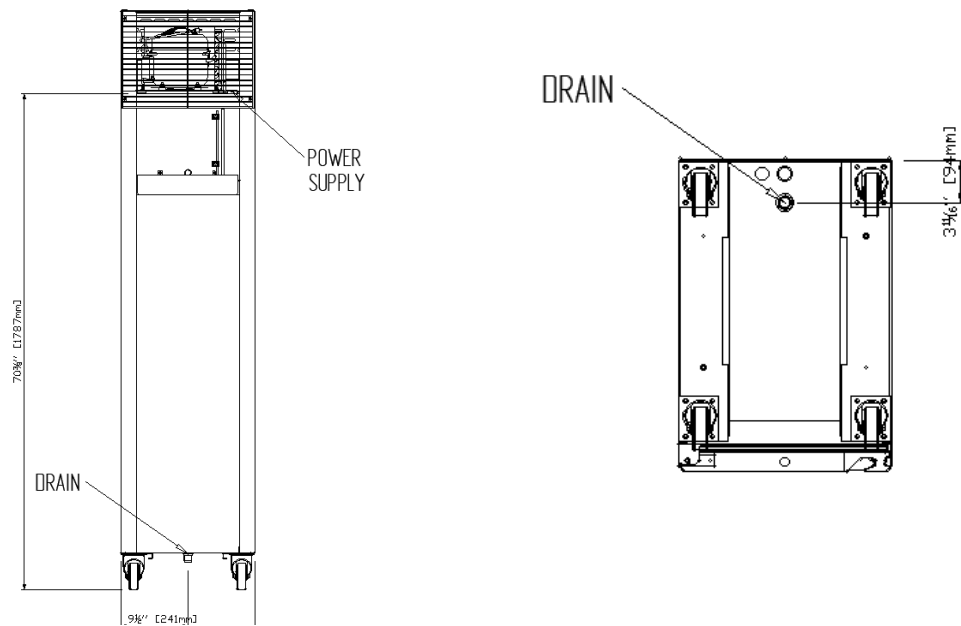

ETL LISTED TO UL471 STANDARD AND SANITATION CLASSIFIED TO NSF7 - WE RESERVE THE RIGHT TO CHANGE SPECIFICATIONS WITHOUT PRIOR NOTICE

