

MADE IN ITALY



Models:

CME-6US / CME-10US

## Standard Features

- AISI 304 Stainless-Steel Rounded Cooking Chamber Construction for better air circulation & cleaning
- Double low emissive glass thermal insulation \*\*\*
- Openable inner glass for easy cleaning
- Boiler-less system
- Nine cooking modes available including Preset Programs, Manual mode, and Customized Programs mode
- 300 Preset Recipes, Storage of up to 1000 recipes, can customize 700 with up to 10 Steps Each
- Integrated WiFi settings
- Pre-loaded and Online cookbook
- Storage, viewing\* and exporting of cooking data
- Multipoint core probe (5 Reading points), non-removable (housing integrated in tray-holder)
- Tray holders included
- Set-up for vacuum core probe
- Multi-fan system: 5 fan speeds
- Fan inversion and motor brake
- Multi-timer function for multiple and mixed cooking
- Automatic control of the cooking level and load
- Automatic Preheating & Cooling
- Delayed start programming
- Automatic chimney opening
- Chamber Relative Humidity % Control with probes: Automated, by selected Percentage/Time, and Manual steam injection
- Self-Cleaning/Disinfection System
- Automatic detection and errors report
- LED illumination
- Ventless option when coupled with CME-Hood

1-year parts and labor warranty (US Only)



CME-6US



CME-10US

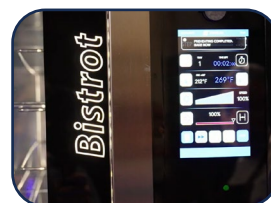

Touch Screen



USB Port



CME HOOD

Coupling the CME Hood with the Combi oven allows it to function as a **Ventless** unit.



Oven Stand

## SPECIFICATIONS

**CME-6US      CME-10US**

	CME-6US	CME-10US
<b>Max Temperature</b>	518°F (270°C)	
<b>Tray Capacity</b> 24"x16" (60x40cm) 18"x26" (46x66cm)	6	10
<b>Power Supply</b>	230V/50-60Hz/1-3ph (field convertible)	
<b>Power (kW)</b>	10	15
<b>Amps</b>	1ph = 48.3 3ph = 27.9	1ph = 72.5 3ph = 41.8
<b>Plug / Connection</b>	No Plug - No Cord	
<b>Product Dim.</b> W x D x H	33.5" x 36.6" x 32.7" 85 x 93 x 83 cm	33.5" x 36.6" x 45.3" 85 x 93 x 115.0 cm
<b>Product Weight</b>	183 lbs (83 Kg)	247 lbs (112 Kg)
<b>Shipping Dim.</b> W x D x H	36.2" x 39.4" x 38.6" 92 x 100 x 98 cm	36.2" x 39.4" x 51.2" 92 x 100 x 130 cm
<b>Shipping Weight (lbs)</b>	223 lbs (101 Kg)	291 lbs (132 Kg)

## Cooking Programs Available

- Convection cooking,
- Steam Cooking,
- Mixed Cooking,
- Delta T cooking with core probe,
- Vacuum cooking,
- In-vase cooking,
- Pasteurization cooking
- And More!

## \*\*\*Double Low Emissive Glass\*\*\* Thermal Insulation

Air gap between internal and external glass allows outer glass to be touched by operator. Internal glass has reflective side to help retain the heat in chamber

OPTIONAL Accessories	CME-6US	CME-10US
<b>Hood</b>	CME Hood	
<b>Stand</b>	6T STAND	10T STAND



Notes:

- Operate at room temperature between 41° and 104°F (5° and 40°C).
- Clearance of 6" required on all sides
- If the oven is positioned next to other units that give off heat (e.g. fryers), appropriate measures must be taken, such as placing protection against radiance.
- Maximum water hardness of 5°f
- Properly clean and dry after daily use to ensure best performance and equipment longevity.



No Plug  
No Cord

\*AMPTO is continuously improving products. Specifications are subject to change without notice.\*

## FRONT VIEW

## REAR VIEW

### CME-6US

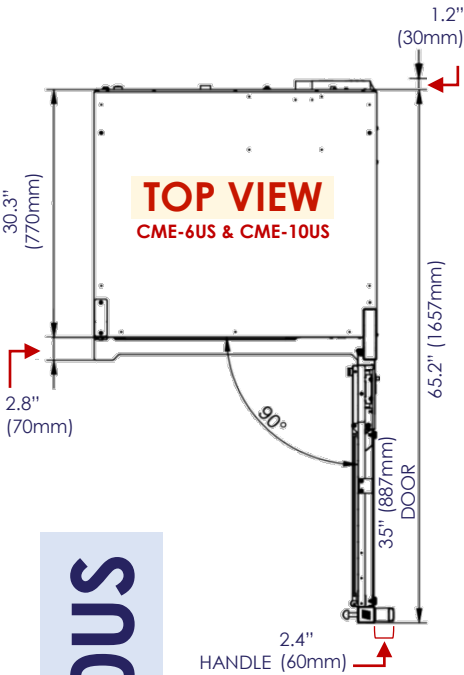
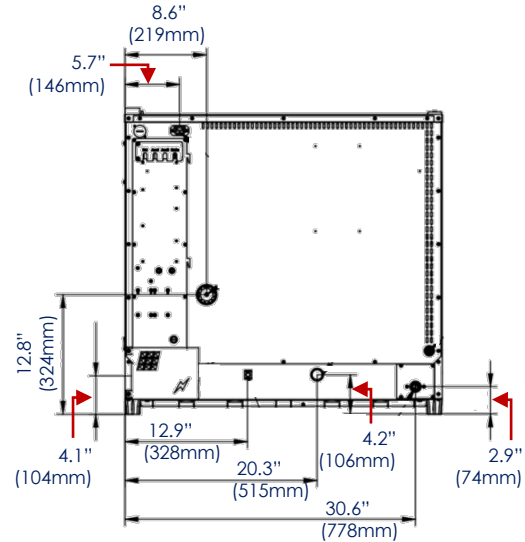
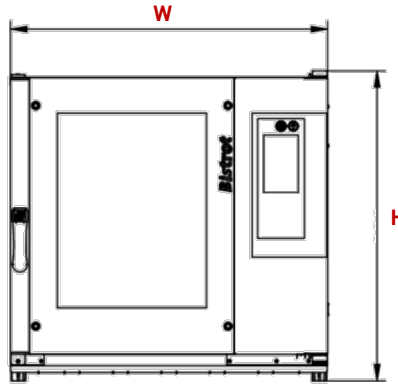

### TOP VIEW

CME-6US & CME-10US

### CME-10US

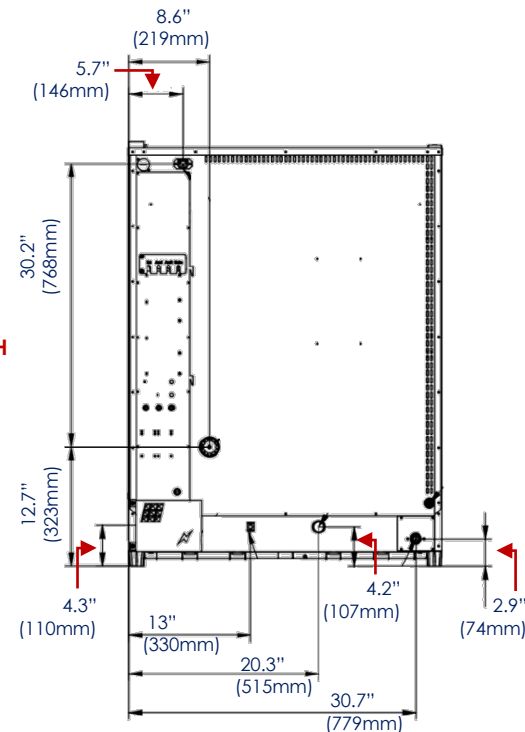
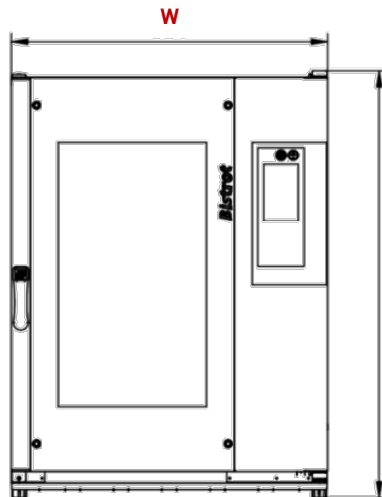

2.4" (60mm) HANDLE